



**CODICE ARPC016**

**Casetta in resina Factor 8x8 Beige**

Dimensioni: cm 256,5 x 255 x 243



**Level the ground surface | Nivelez la surface du sol | Nivele la superficie del suelo | Ebnen Sie die Bodenoberfläche | Maak de bodem vlak | Livellare la superficie del terreno | Nivele a superfície do solo**



**Recommendation: Construct a wooden or concrete base as a foundation | Recommandation : Fabriquez une base en bois ou en béton en guise de fondation | Recomendación: construya una base de madera o de cemento a modo de cimiento | Empfehlung: Bauen Sie als Fundament eine Grundfläche aus Holz oder Beton | Aanbeveling: maak een houten of betonnen ondergrond als fundering | Raccomandazione: Costruire una base di legno o di cemento come fondamenta | Recomendação: Construa uma base de madeira ou de cimento como fundação**

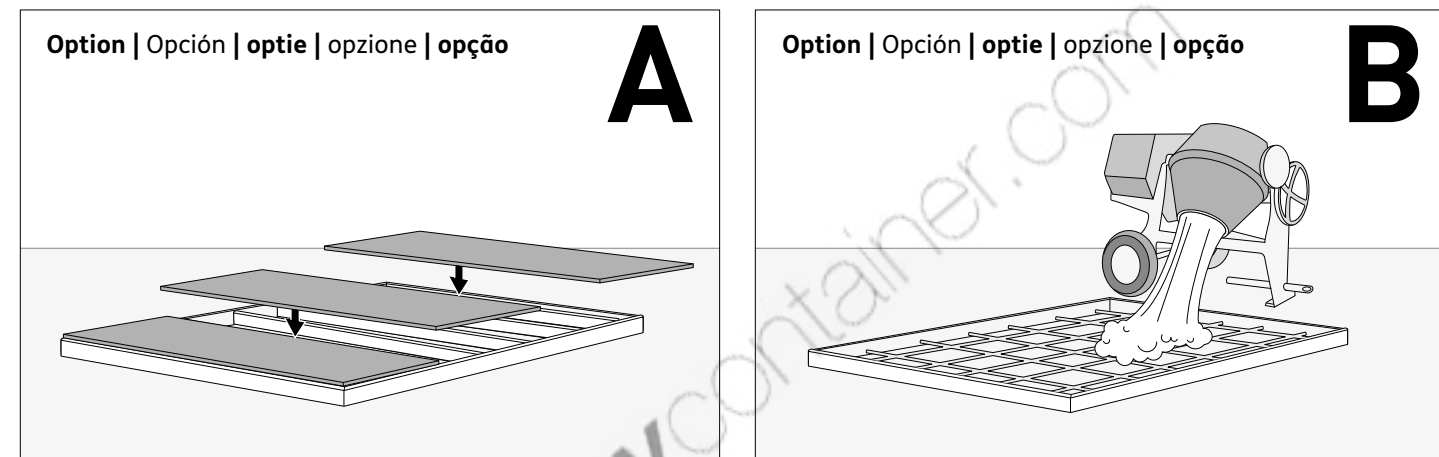

**For external access during assembly, make sure to leave enough room around the outside of the shed assembly site.**

Pour un accès externe au cours du montage, veillez à laisser suffisamment de place autour du site de montage.

**Para tener un acceso exterior durante el montaje, asegúrese de dejar suficiente espacio alrededor del lugar de montaje del cobertizo.**

Lassen Sie am Aufstellungsort außerhalb des Schuppens ausreichend Platz, so dass Sie während des Aufbaus von außen Zugang zum Schuppen haben.

**Om tijdens de montage aan de buitenkant van het schuurtje te kunnen werken, moet u ervoor zorgen dat u genoeg ruimte laat aan de buitenkant van de montageplaats.**

Per accedere alle parti esterne della casetta durante l'assemblaggio, assicurarsi di lasciare abbastanza spazio attorno al luogo di assemblaggio.

**Para ter acesso externo durante a montagem certifique-se de que deixa espaço suficiente em redor do exterior do local de montagem do abrigo.**

**External floor measurements are: | Mesures externes du plancher: | Las medidas del suelo externo son: | Die Außen-Bodenmaße betragen: | De afmetingen van de externe vloer zijn: | Le dimensioni esterne del pavimento sono: | As medidas externas do chão são:**

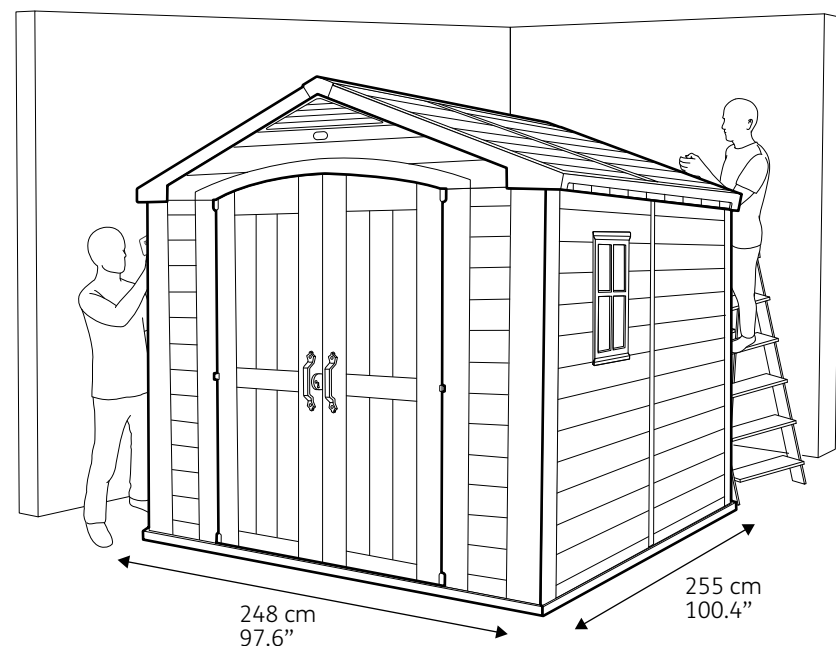

**Read the care and safety guidelines at the end of this manual | Check to ensure that there are no missing or damaged parts BEFORE starting or arranging assembly | Remove all parts from the package(s) and spread them out on a clean work surface | Review all assembly instructions | Assemble all the parts according to the directions in this manual. Do not skip any steps.**

Lisez les instructions de précaution et de sécurité à la fin de ce manuel | Assurez-vous qu'il n'y a pas de pièces manquantes ou endommagées AVANT de commencer ou d'organiser l'assemblage | Retirez toutes les pièces du/des paquet(s) et étalez-les sur une surface de travail propre | Lisez toutes les instructions de montage | Assemblez toutes les pièces selon les instructions de ce manuel. Ne sautez aucune étape.

**Lea las instrucciones de precauciones y seguridad que están al final de este manual | Asegúrese de que no faltan piezas ni están dañadas ANTES de comenzar o disponer el montaje | Saque todas las piezas del paquete o paquetes y póngalas sobre una superficie de trabajo limpia | Revise todas las instrucciones de montaje | Monte todas las piezas según las instrucciones de este manual. No se saltee ningún paso.**

Lesen Sie die Sicherheitsrichtlinien am Ende des Benutzerhandbuchs durch | Prüfen Sie bitte VOR dem Zusammenbau, dass keine Teile beschädigt sind oder fehlen | Nehmen Sie alle Teile aus der Verpackung und breiten Sie sie auf einer sauberen Arbeitsfläche aus | Gehen Sie noch einmal die komplette Aufbauanleitung durch | Bauen Sie alle Teile entsprechend der Anleitung in diesem Handbuch zusammen. Lassen Sie dabei keinen Arbeitsschritt aus.

**Lees de richtlijnen voor zorg en veiligheid achterin deze handleiding | Controleer dat er geen onderdelen mankeren, of beschadigd zijn, VOORDAT u met de montage begint | Haal alle onderdelen uit het pakket (of uit de pakketten) en leg ze open schoon werkoppervlak | Bekijk alle montagehandleidingen | Monteer alle onderdelen volgens de aanwijzingen van deze handleiding. Sla geen stappen over.**

Leggere le linee guida di assistenza e sicurezza alla fine di questo manuale | Assicurarsi che non ci siano parti mancanti o danneggiate PRIMA di iniziare l'assemblaggio | Estrarre tutti i componenti dall'imballo e posizzarli su una superficie di lavoro pulita | Consultare tutte le istruzioni di montaggio | Assemblare tutti i componenti secondo le istruzioni contenute nel manuale. Non saltare nessuna fase.

**Leia as diretrizes de cuidados e segurança que constam da parte final deste manual | Verifique para se assegurar de que não há peças em falta ou danificadas ANTES de começar a preparar a montagem | Retire todas as peças da embalagem e espalhe-as numa superfície de trabalho limpa | Reveja todas as instruções de montagem | Monte todas as peças de acordo com as instruções do manual. Não salte quaisquer passos.**

**REQUIRED TOOLS | OUTILS EXIGÉS | HERRAMIENTAS NECESARIAS | BENÖTIGTE WERKZEUGE | BENODIGD GEREEDSCHAP | ATTREZZATURA OCCORRENTE | FERRAMENTAS NECESSÁRIAS**

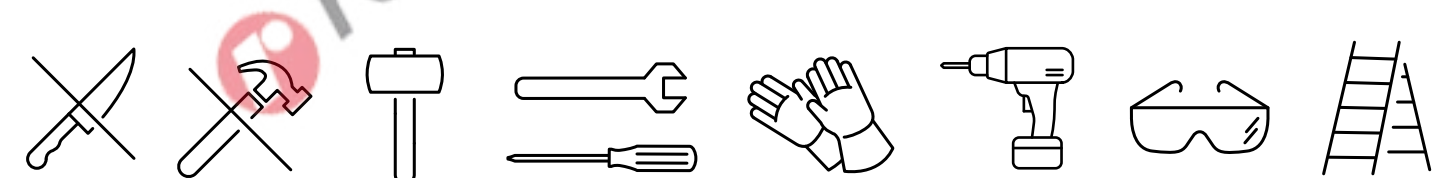

**ASSEMBLY REQUIRES TWO PEOPLE | LE MONTAGE DOIT ÊTRE EFFECTUÉ PAR DEUX PERSONNES | SE NECESITAN DOS PERSONAS PARA EL MONTAJE | ZWEI PERSONEN ZUR MONTAGE NOTWENDIG | MONTAGE VEREIST TWEE PERSONEN | L'ASSEMBLAGGIO RICHIEDE DUE PERSONE | A MONTAGEM EXIGE DUAS PESSOAS**

**SHED PARTS | PIÈCES DE L'ABRI | PARTES DEL COBERTIZO | TEILE DES SCHUPPENS | ONDERDELEN VAN HET SCHUURTJE | COMPONENTI DELLA CASETTA | PEÇAS DO ABRIGO**

Remove all parts from the package(s) and spread them out on a clean work surface. Code letters are imprinted on each part for easy identification | Retirez toutes les pièces du/des paquet(s) et étalez-les sur une surface de travail propre. Des lettres sont imprimées sur chaque pièce pour une identification facile | Saque todas las piezas del paquete o paquetes y póngalas sobre una superficie de trabajo limpia. El código de letras está marcado en cada pieza para que sea más fácil identificarla | Nehmen Sie alle Teile aus der Verpackung und breiten Sie sie auf einer sauberen Arbeitsfläche aus. Auf jedem Teil sind Kennbuchstaben aufgedruckt, die die Zuordnung der einzelnen Teile erleichtern | Haal alle onderdelen uit het pakket (of uit de pakketten) en leg ze op een schoon werkoppervlak. Op ieder onderdeel zijn codes aangebracht om ze eenvoudig te kunnen herkennen | Rimuovere tutti i componenti dall'imballo e posizzionarli su una superficie di lavoro pulita. I codici identificativi sono impressi in ogni componente per una semplice identificazione | Retire todas as peças da embalagem e espalhe-as numa superfície de trabalho limpa. Existem letras de código impressas em cada peça para fácil identificação

**ROOF PARTS | PIÈCES DU TOIT | PARTES DEL TECHO | DACHELEMENTE | DAKONDERDELEN | COMPONENTI DEL TETTO | PEÇAS DO TELHADO**

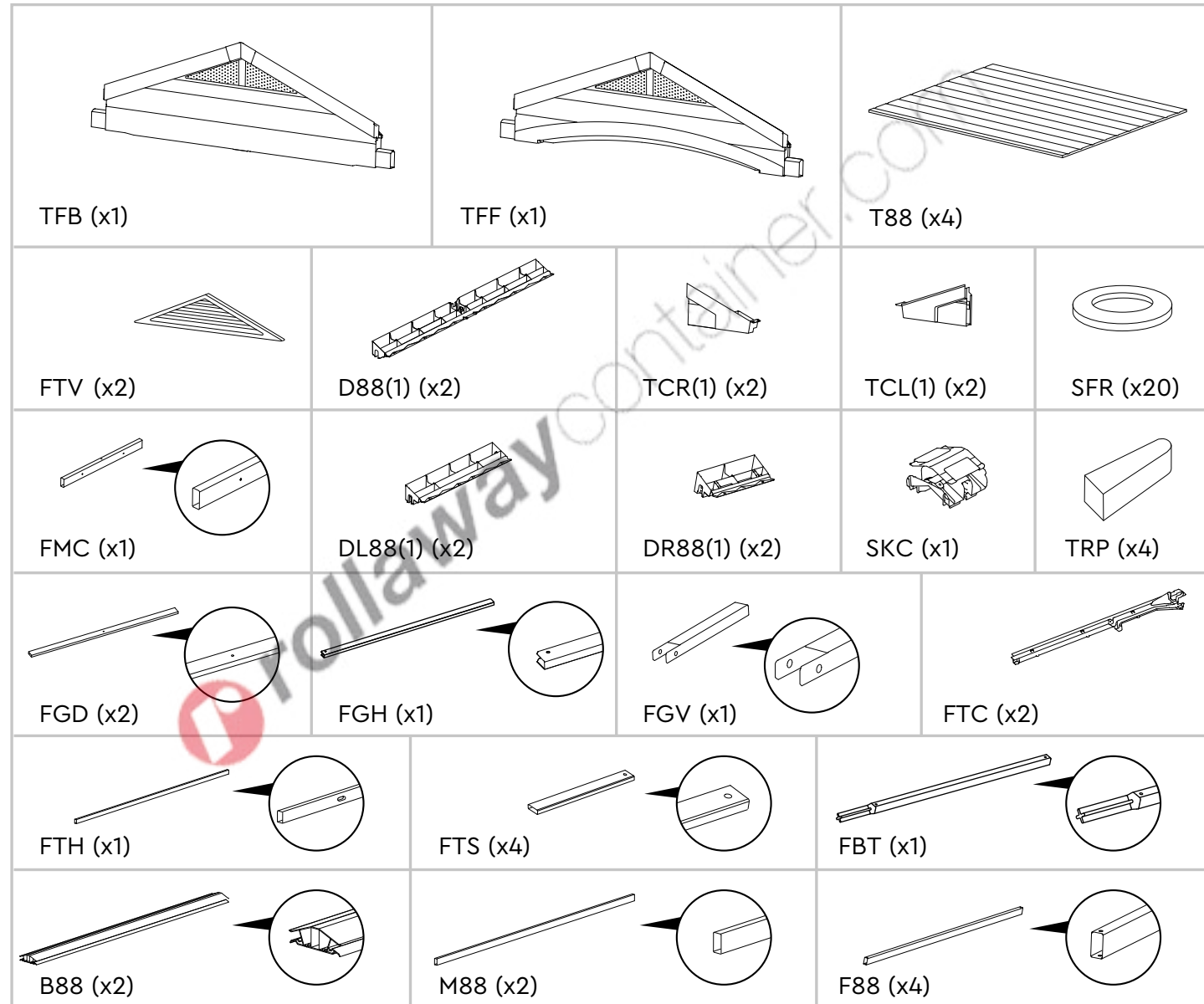

**SHELVES | ÉTAGÈRES | REGALE | ESTANTES | PLANKEN | MENSOLE | PRATELEIRAS**

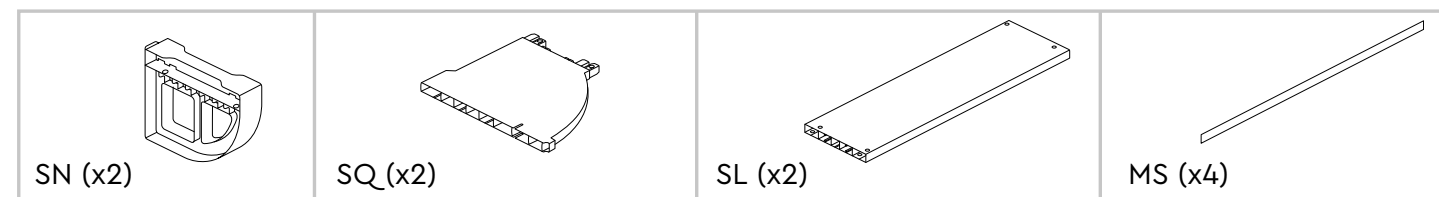

**FLOOR PARTS | ÉLÉMENTS DU PLANCHER | PARTES DEL SUELO | BODENTEILE | VLOERPANELEN | COMPONENTI DEL PAVIMENTO | PEÇAS DO CHÃO**

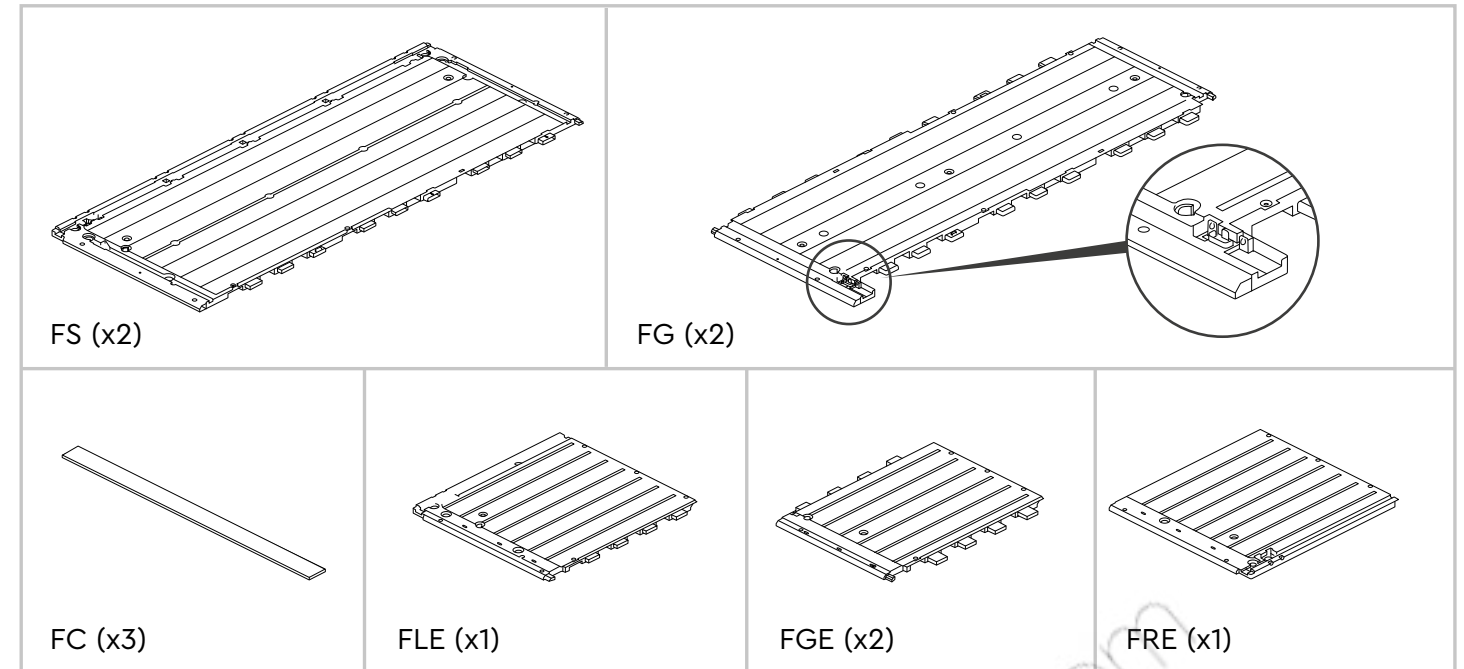

**DOOR PARTS | PIÈCES DE LA PORTE | PARTES DE LA PUERTA | TÜRELEMENTE | DEURONDERDELEN | COMPONENTI DELLA PORTA | PEÇAS DAS PORTAS**

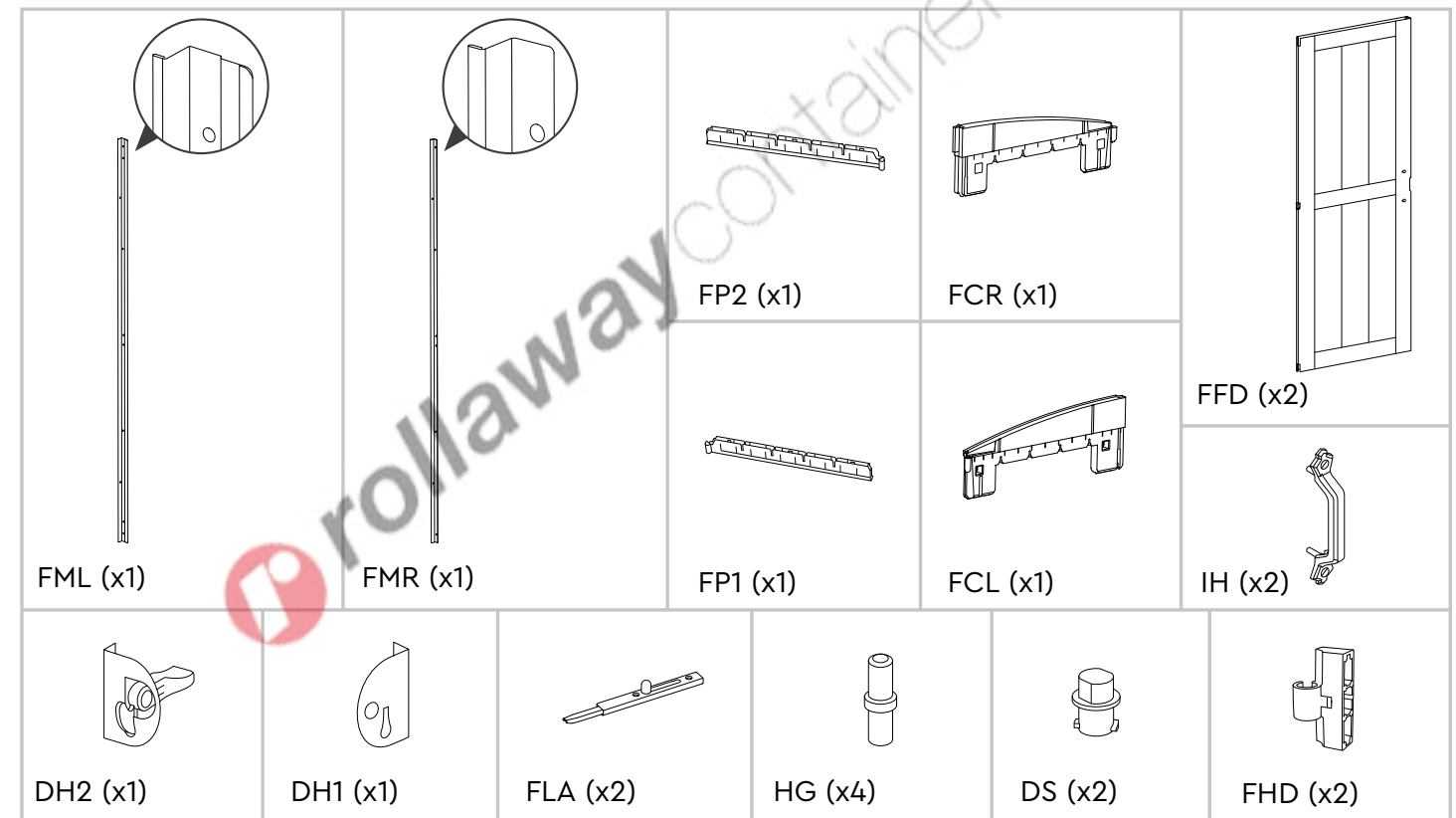

**WINDOW PARTS | PIÈCES DE LA FENÊTRE | PARTES DE LA VENTANA | FENSTERELEMENTE | VENSTERONDERDELEN | COMPONENTI DELLA FINESTRA | PEÇAS DA JANELA**

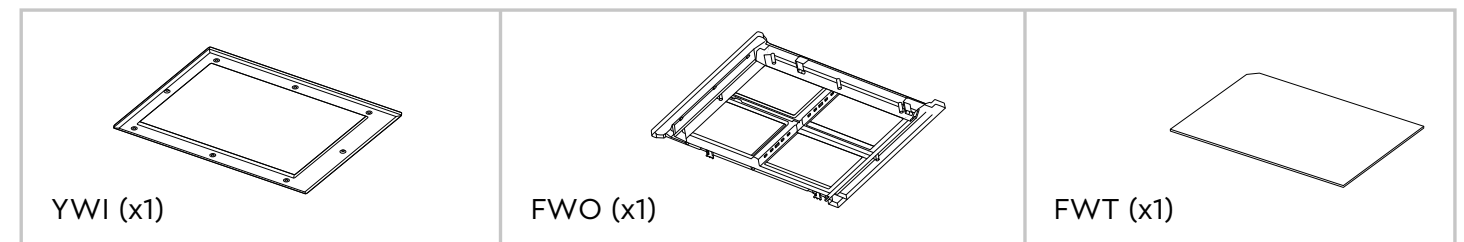



**WALL PARTS | PIÈCES DES MURS | PARTES DE LAS PAREDES | WANDELEMENTE | MUURONDERDELEN | COMPONENTI DELLA PARETE | PAINÉIS LATERAIS**

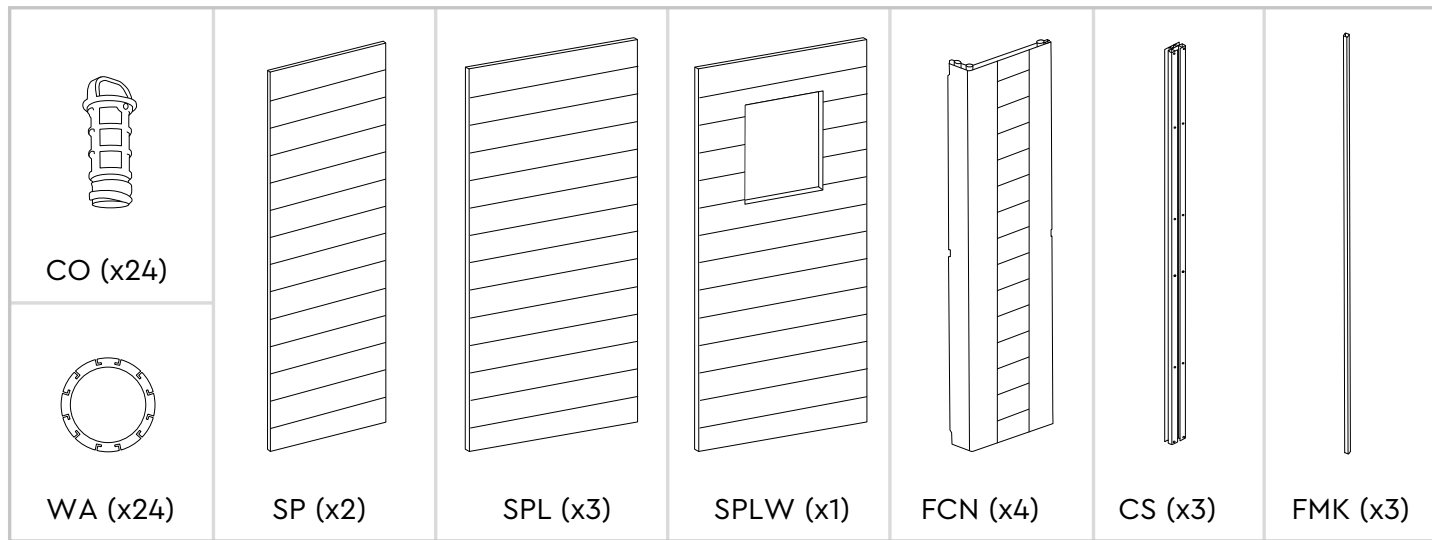

**SCREWS | VIS | TORNILLOS | SCHRAUBEN | SCHROEVEN | VITI | PARAFUSOS**

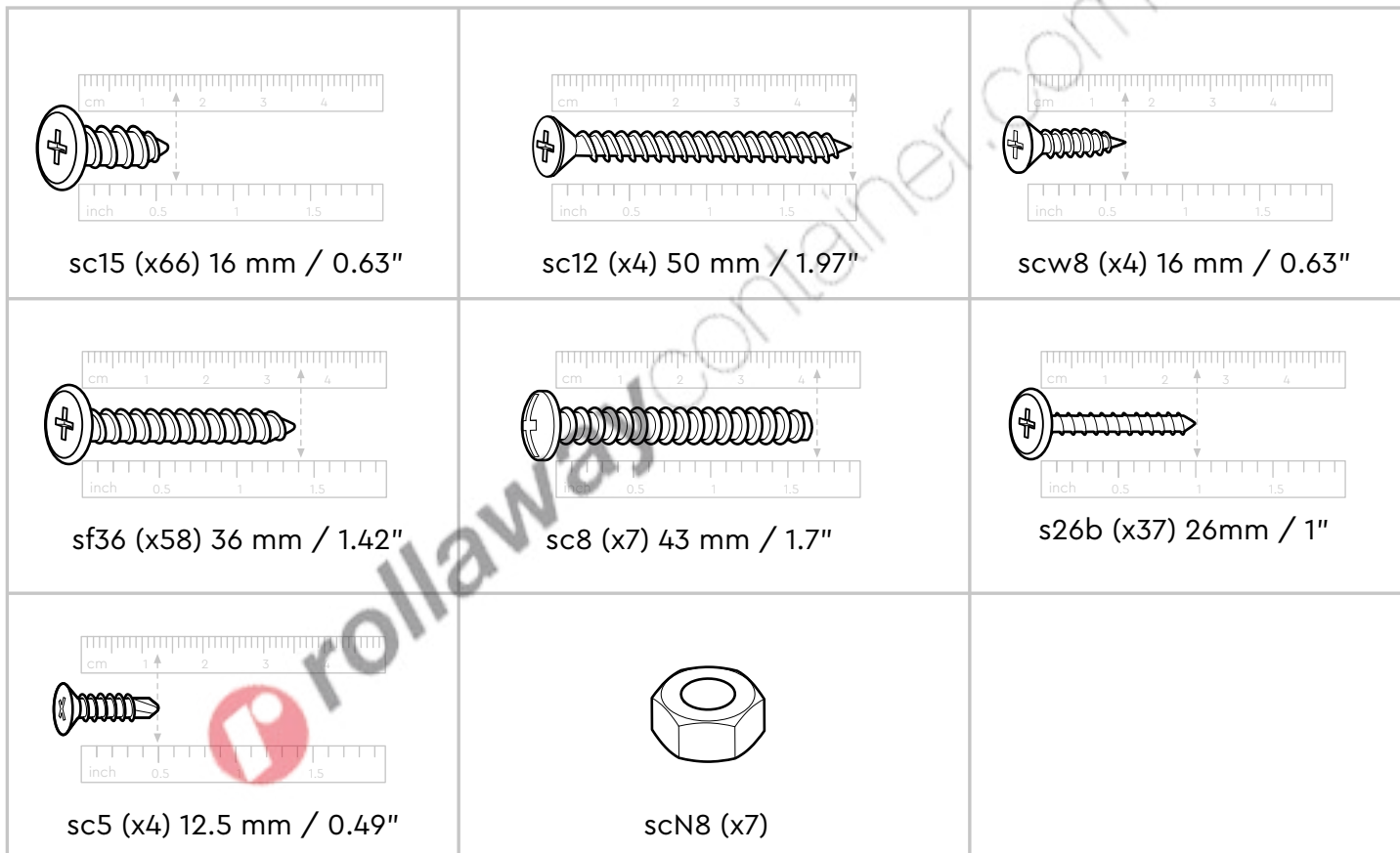

**Packaging may contain some additional small parts for use as spare parts | L'emballage peut contenir de petites pièces supplémentaires à utiliser comme pièces de rechange | El envoltorio puede contener algunas piezas pequeñas adicionales que se pueden utilizar como repuestos | In der Verpackung können kleine Zusatzteile enthalten sein, die als Ersatzteile genutzt werden können | De verpakking kan een aantal kleine extra onderdelen bevatten, die als reserveonderdeel gebruikt kunnen worden | L'imballo potrebbe contenere piccoli componenti supplementari da utilizzare come ricambistica | A embalagem pode conter algumas pequenas peças adicionais para utilização como peças de reposição**

**NOTE:** Due to variations in production, the actual assembled size may vary slightly from the specified dimensions.

**REMARQUE:** En raison de variantes dans la production, la taille de montage réelle peut différer quelque peu des dimensions indiquées.

**NOTA:** debido a las variaciones en la producción, el tamaño real al montarlo puede variar ligeramente con respecto a las dimensiones especificadas.

**BITTE BEACHTEN:** Aufgrund von Abweichungen in der Herstellung kann die tatsächliche Größe leicht von den angegebenen Maßen abweichen.

**LET OP:** vanwege afwijkingen in de productie kan de werkelijke afmeting na montage een klein beetje afwijken van de opgegeven afmetingen.

**NOTA:** A causa di variazioni nella produzione, le dimensioni effettive del prodotto assemblato potrebbero variare leggermente da quelle indicate.

**NOTA:** Devido a variações na produção o tamanho real da montagem poderá variar ligeiramente das dimensões especificadas.

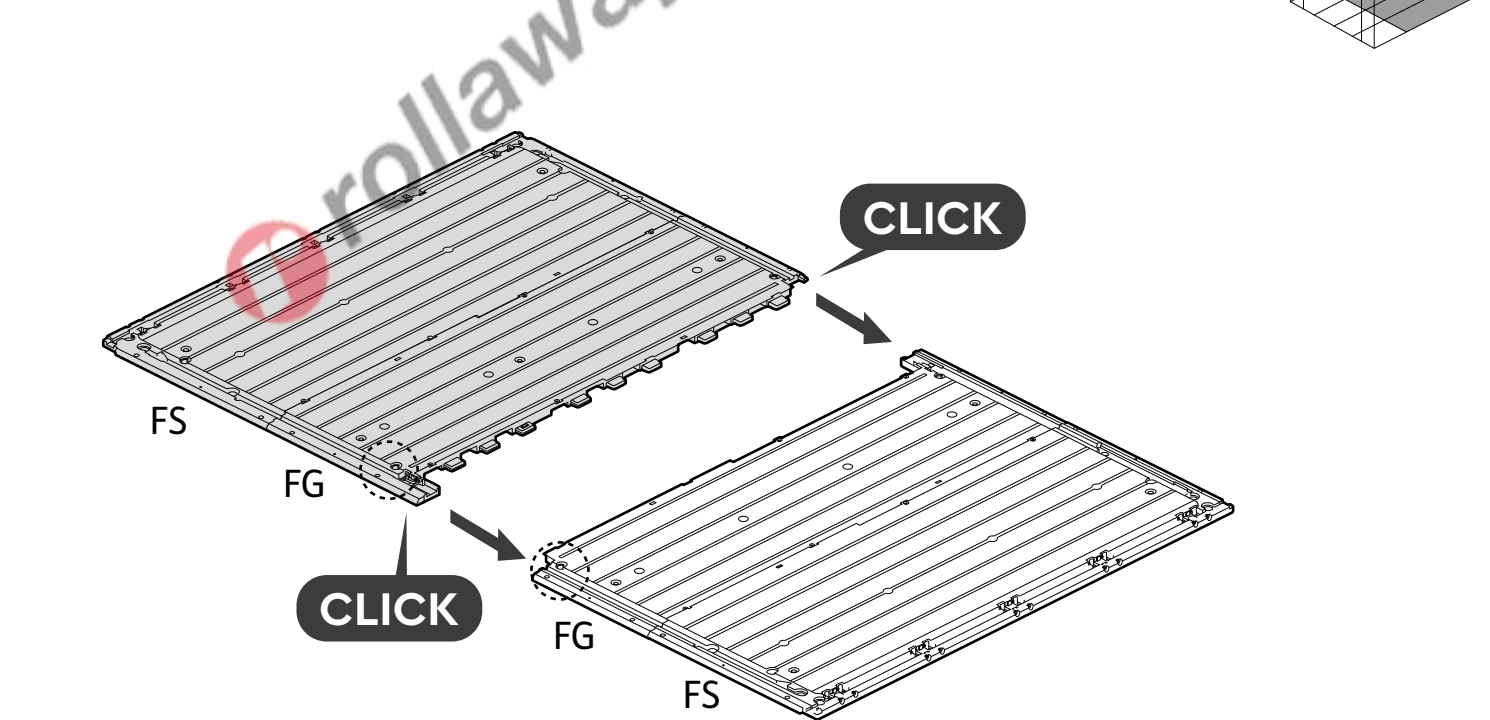
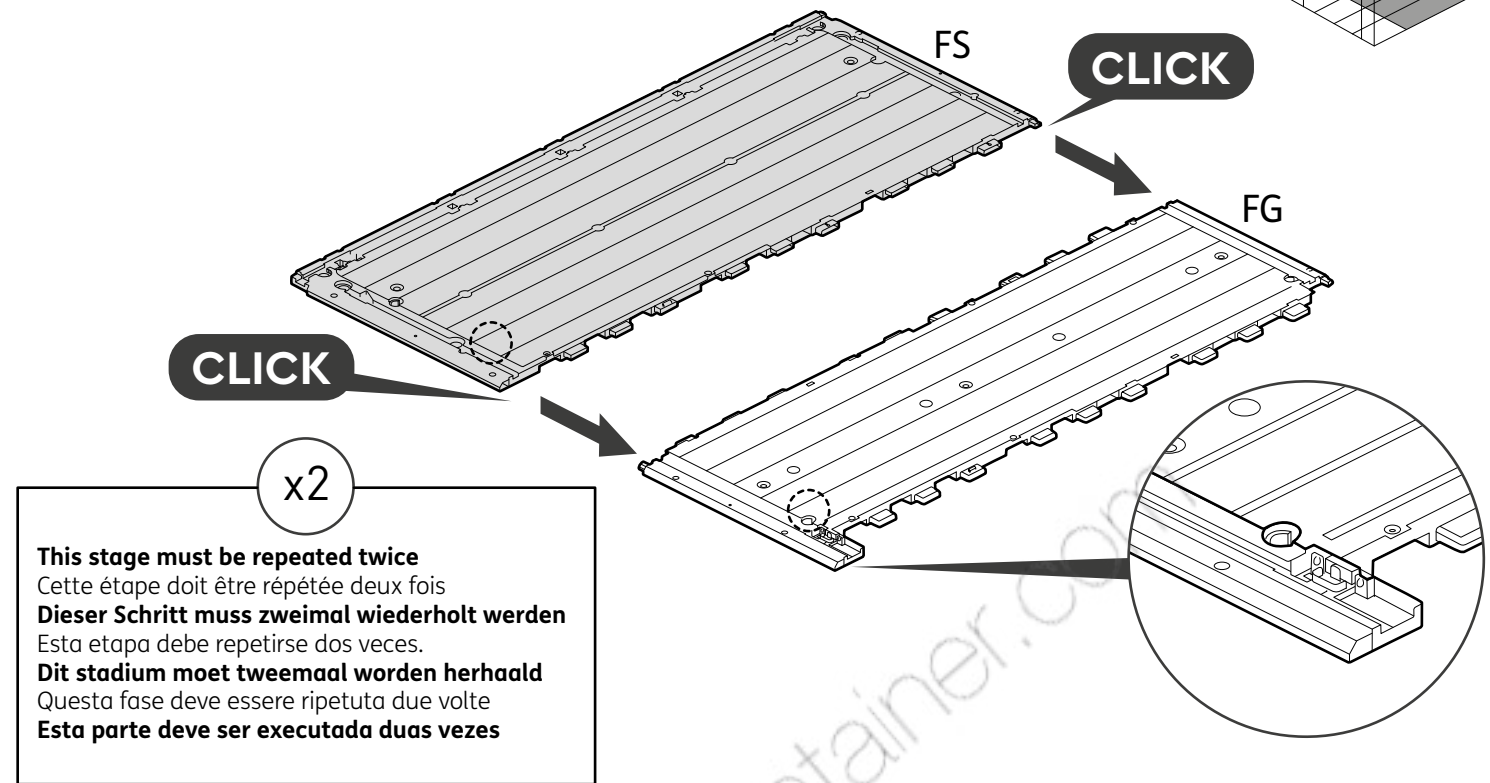

**FLOOR ASSEMBLY | MONTAGE DU PLANCHER | MONTAJE DEL SUELO | MONTAGE DER BODENPLATTE | VLOERMONTAGE | ASSEMBLAGGIO DEL PAVIMENTO | MONTAGEM DO PISO**



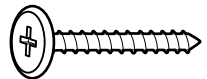

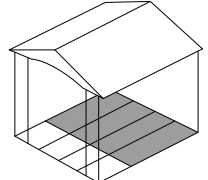
3 |  s26b (x12)

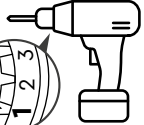



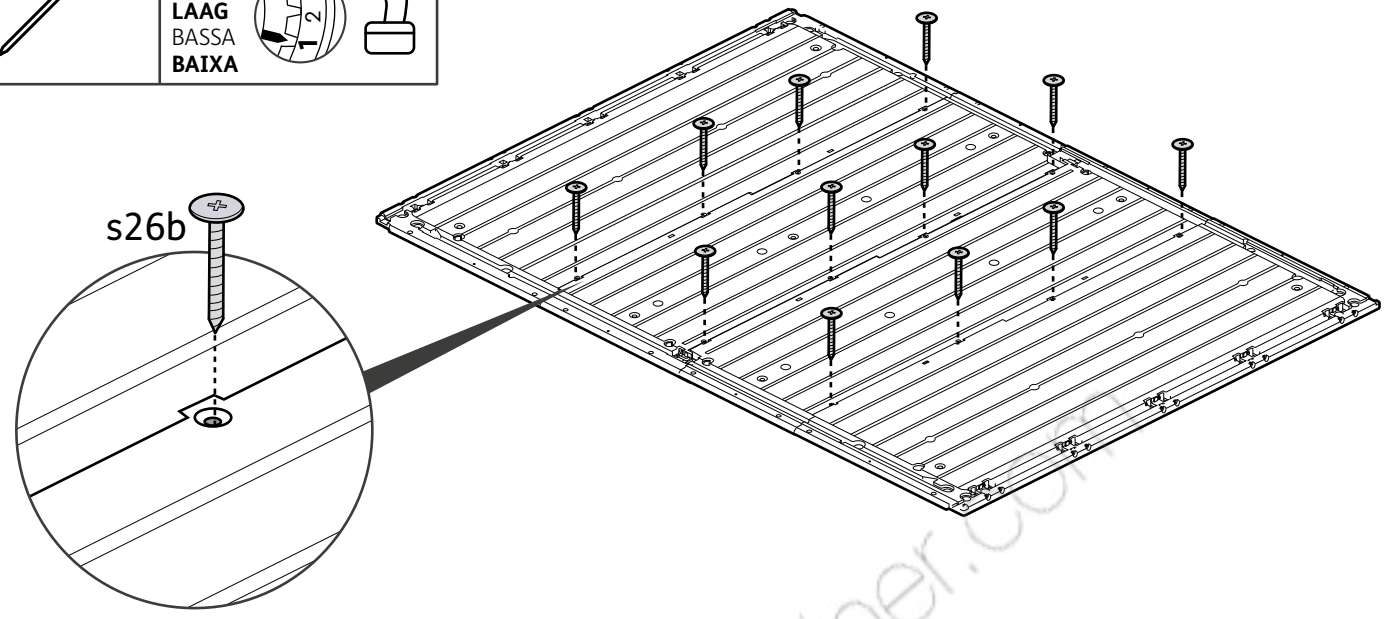

!    

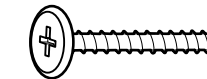
**LOW**  
**FAIBLE**  
**BAJO**  
**NIEDRIG**  
**LAAG**  
**BASSA**  
**BAIXA**

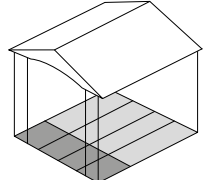

5 |  s26b (x3)

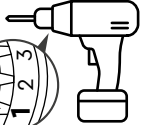

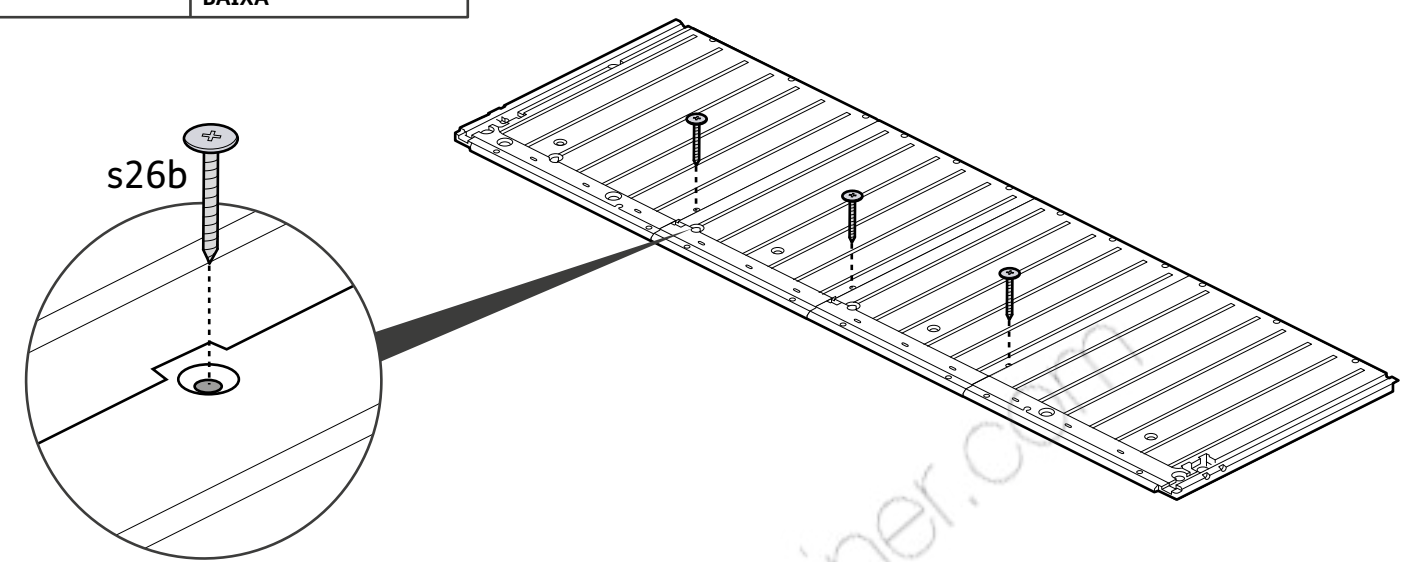

!    

**LOW**  
**FAIBLE**  
**BAJO**  
**NIEDRIG**  
**LAAG**  
**BASSA**  
**BAIXA**

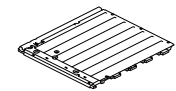
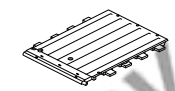
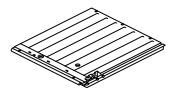

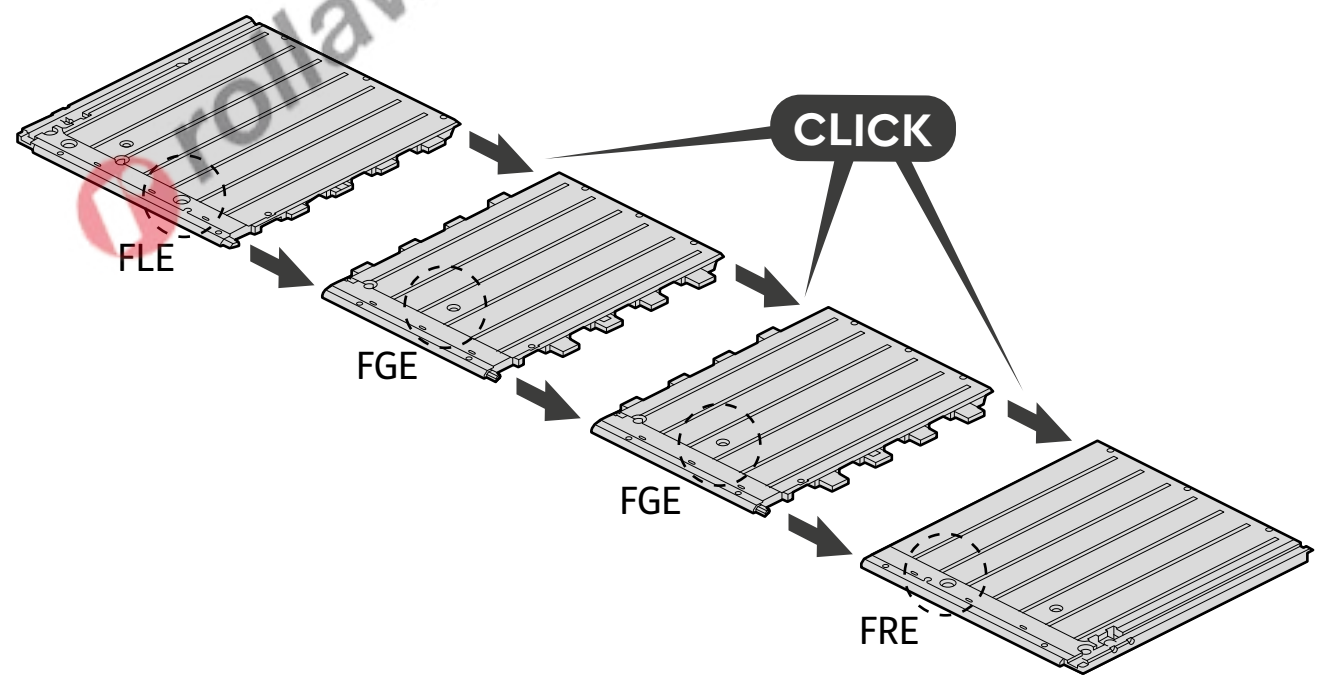
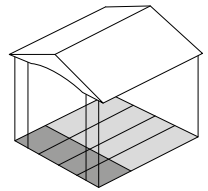
4 |  FLE (x1) |  FGE (x2) |  FRE (x1)

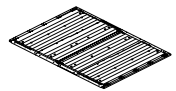

6 |  (x1) |  (x1)

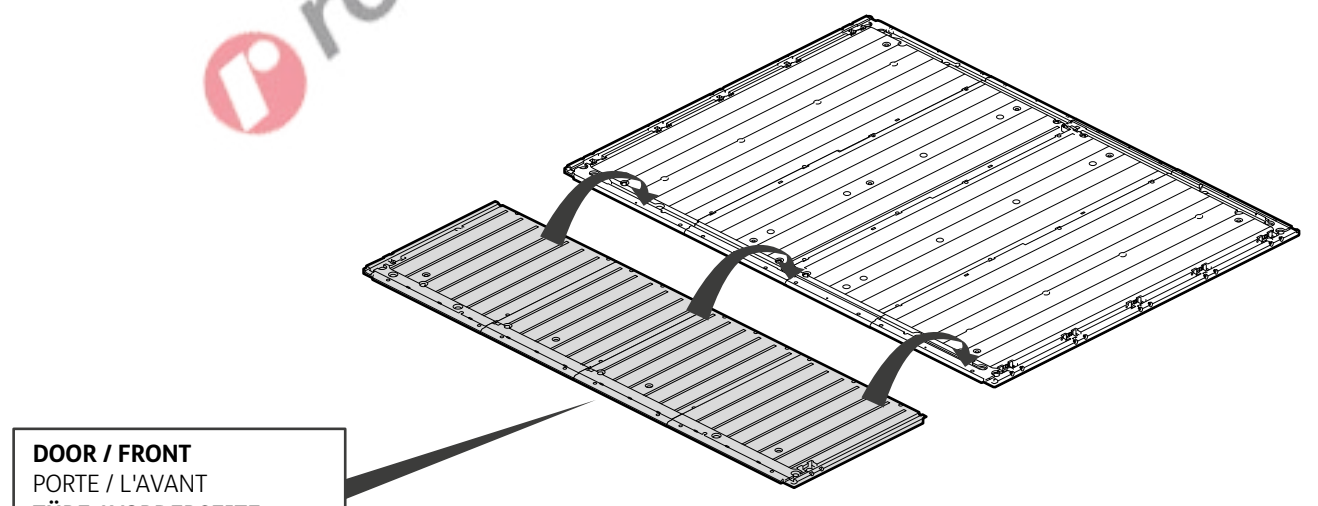
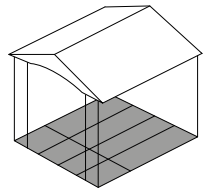

**DOOR / FRONT**  
**PORTE / L'AVANT**  
**TÜRE / VORDERSEITE**  
**PUERTA / PARTE DELANTERA**  
**DEUR / VOORKANT**  
**PORTA / PARTE ANTERIORE**  
**PORTA / PARTE DA FRENTE**

7

s26b (x12)

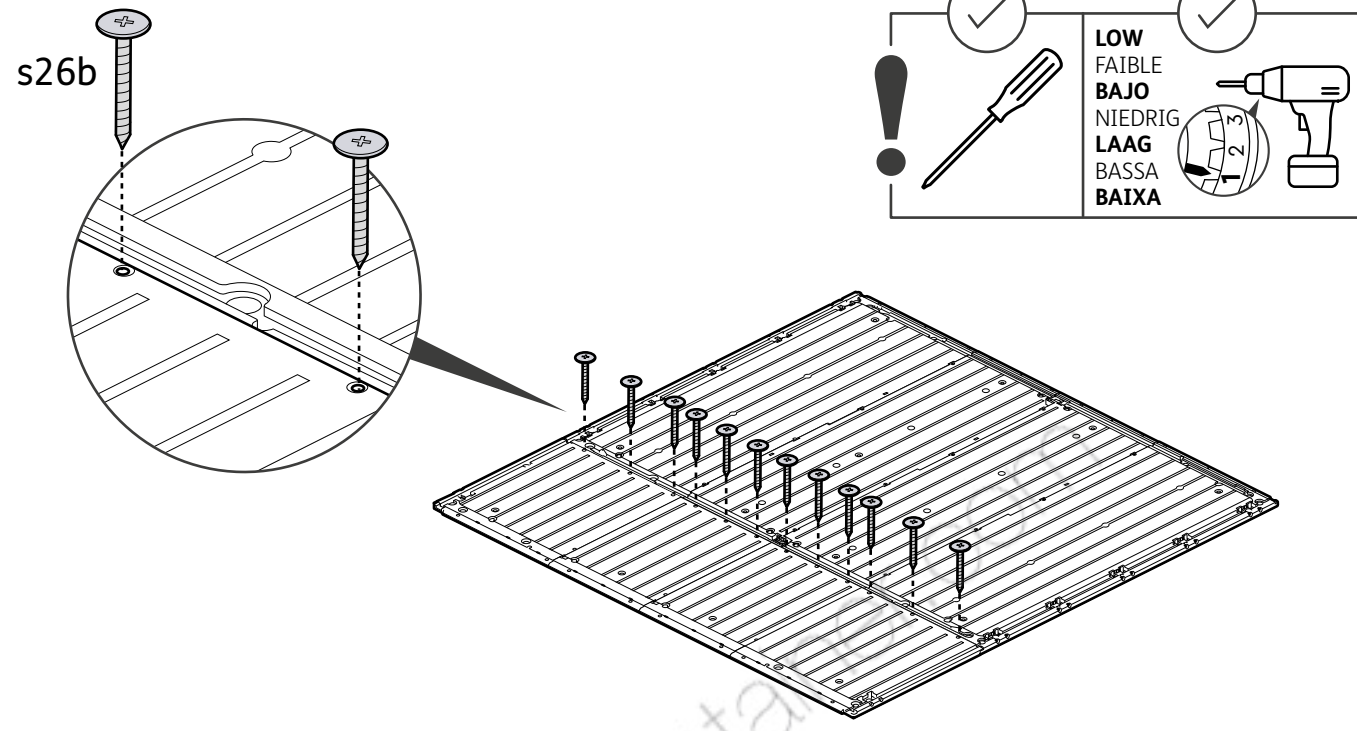
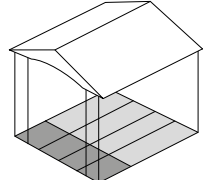

WALL ASSEMBLY | MONTAGE DU MUR | MONTAJE DE LAS | MONTAGE DER WÄNDE | MONTAGE VAN DE MUREN | ASSEMBLAGGIO DELLE PARETI | MONTAGEM DA PAREDE

8

FCN (x1) | WA (x3) | CO (x3)

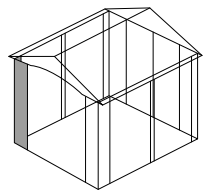

DOOR / FRONT  
PORTE / L'AVANT  
TÜRE / VORDERSEITE  
PUERTA / PARTE DELANTERA  
DEUR / VOORKANT  
PORTA / PARTE ANTERIORE  
PORTA / PARTE DA FRENTE

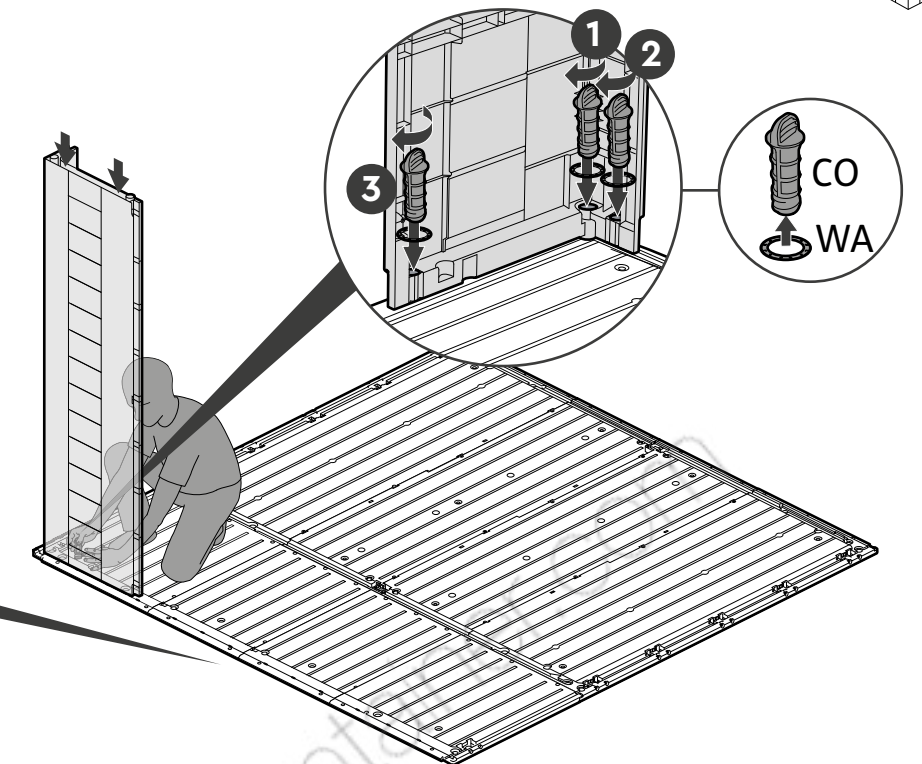

FCN (x4)

Ensure all snap locks are secured before continuing assembly | Compruebe que todos los cierres rápidos estén asegurados antes de continuar con el montaje | S'assurer que tous les fermoirs à cliquet sont sécurisés avant de poursuivre l'assemblage | Stellen Sie sicher, dass alle Schnappverschlüsse gesichert sind, bevor Sie mit der Montage fortfahren | Zorg ervoor dat alle knipsloten vastzitten voordat u verdergaat met assembleren | Assicurarsi che gli innesti siano incastrati prima di procedere con l'assemblaggio | Certifique-se de que todas as travas de segurança estão presas antes de prosseguir com a montagem

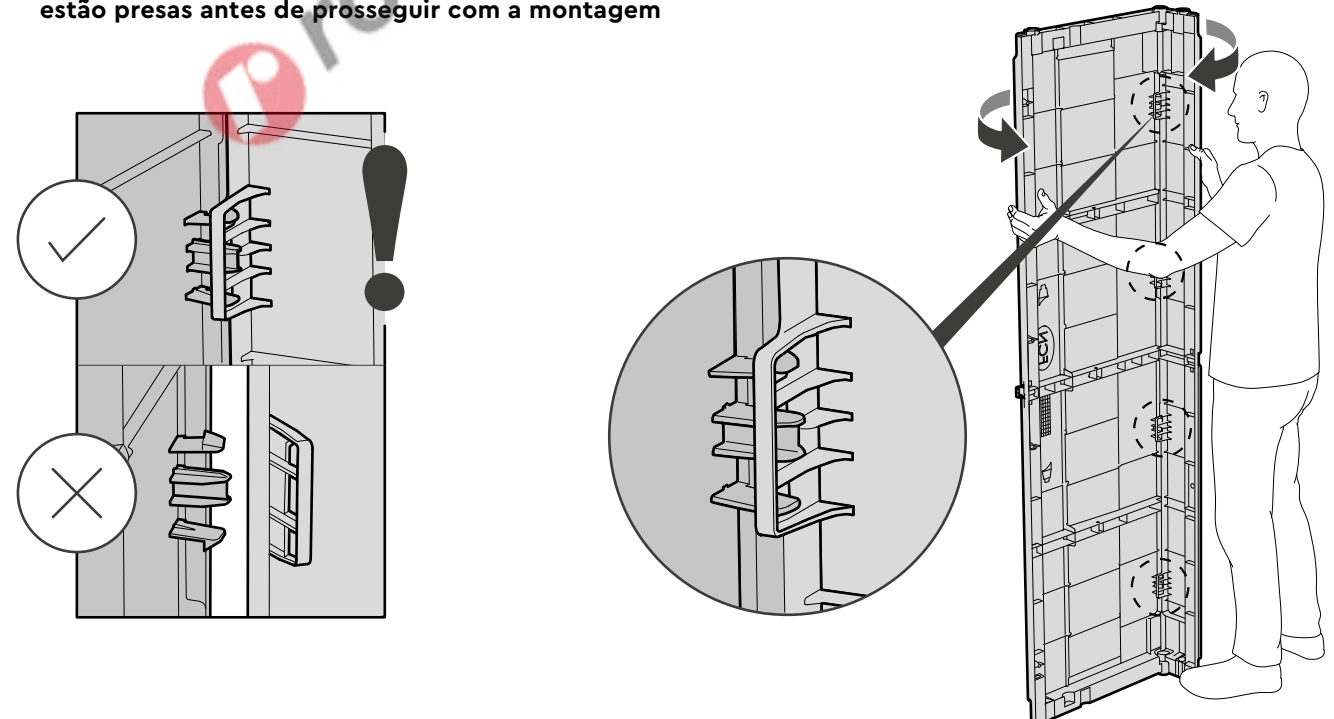

CHOOSE THE LOCATION OF THE WINDOW | CHOISISSEZ L'EMPLACEMENT DE LA FENÊTRE | ELIJA DÓNDE QUIERE COLOCAR LA VENTANA | WÄHLEN SIE AUS, WO SIE DAS FENSTER ANBRINGEN MÖCHTEN | KIES WAAR U HET VENSTER WILT HEBBEN | SCEGLIERE DOVE POSIZIONARE LA FINESTRA | ESCOLHA ONDE QUER COLOCAR A JANELA

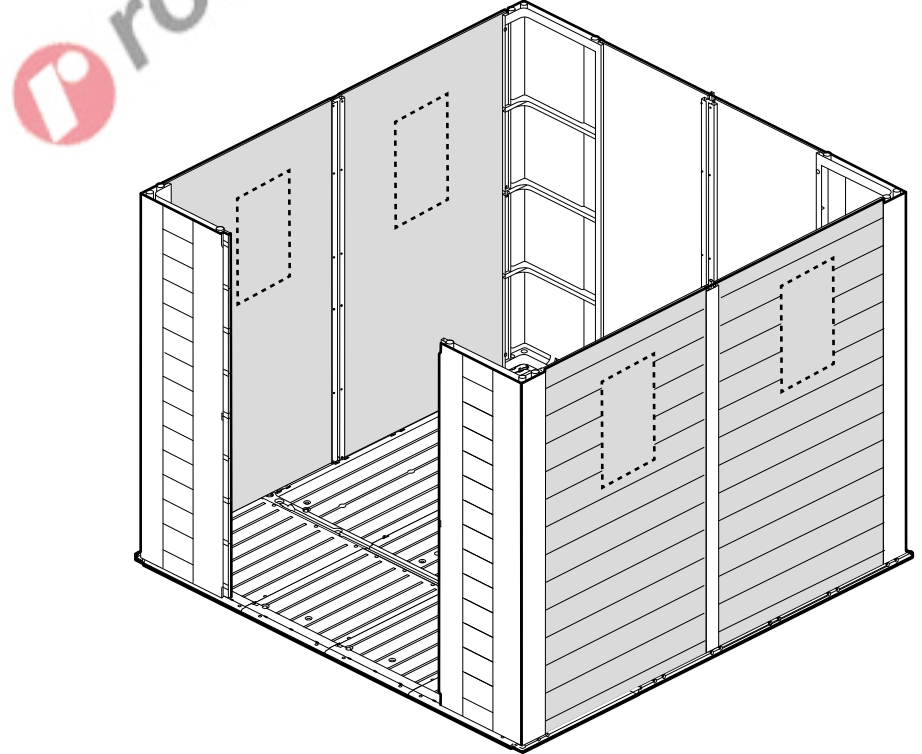

9

SPL/SPLW (x1)

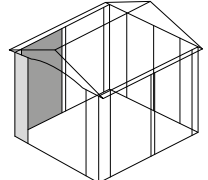

**!**

**Outside**  
 Extérieure  
 Exterior  
 Außenseite  
**Buitenkant**  
 Esterno  
 Exterior

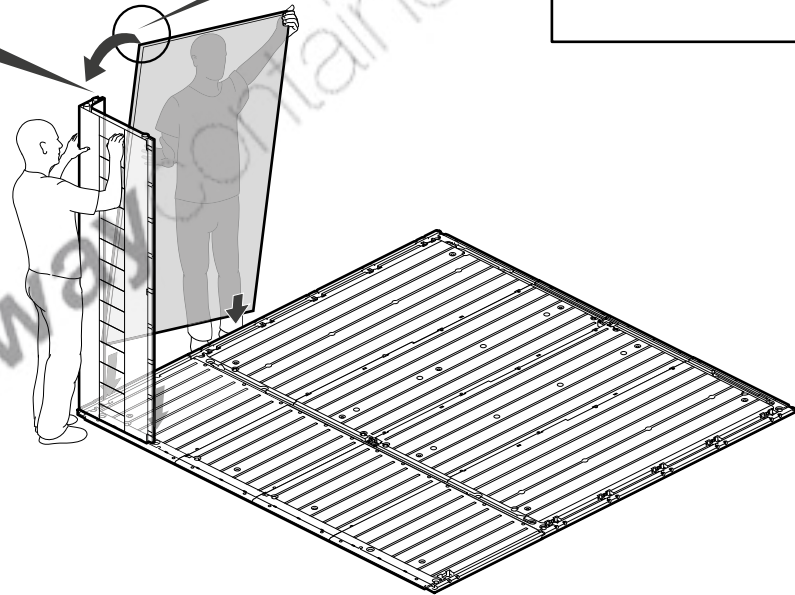
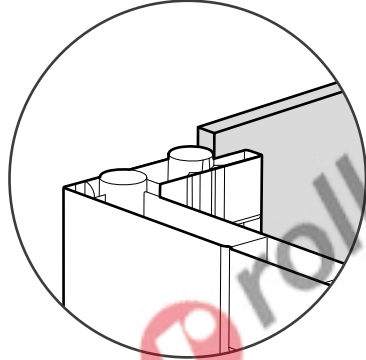
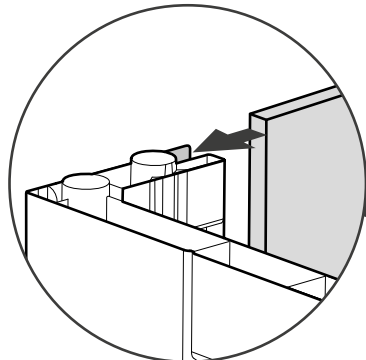
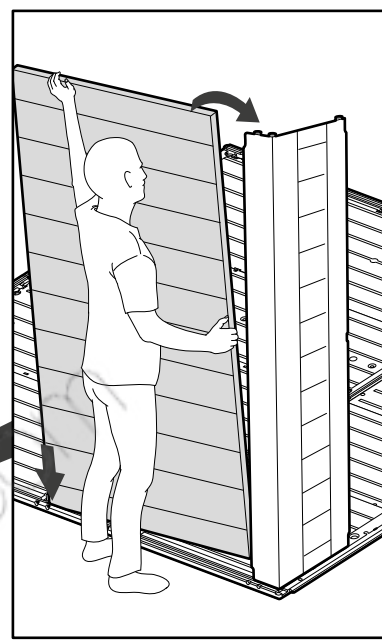

10

CS (x3) | FMK (x3)

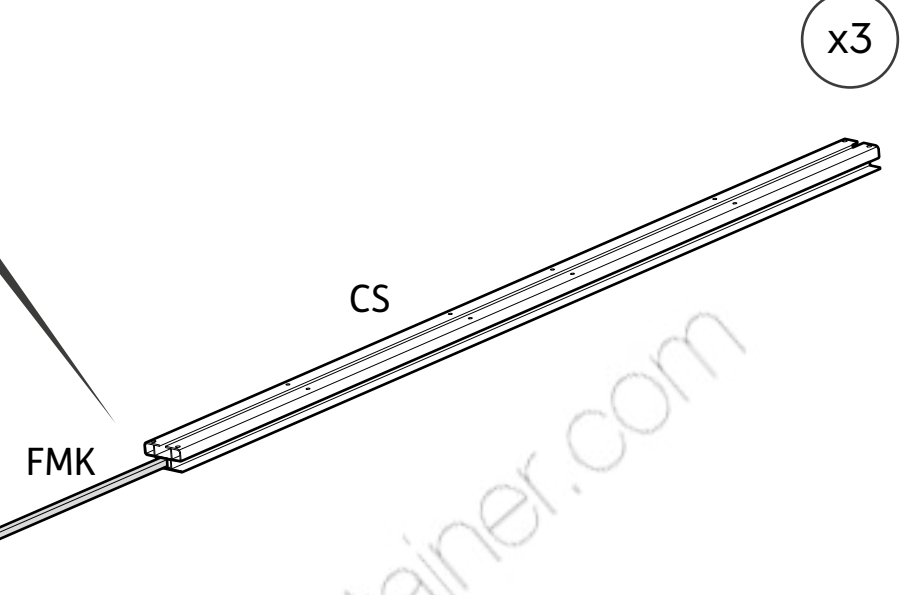
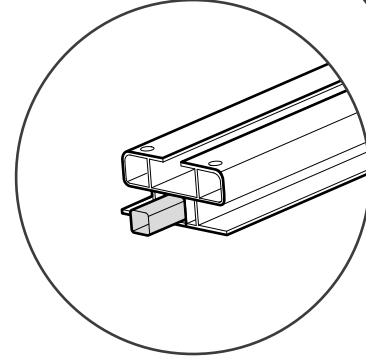
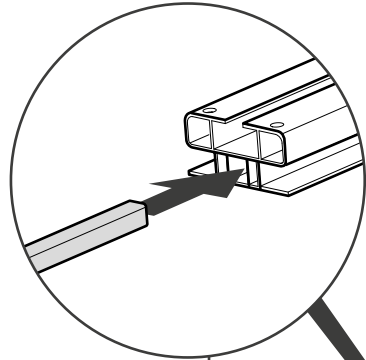
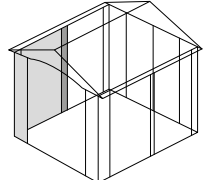

11

CS+FMK (x1)

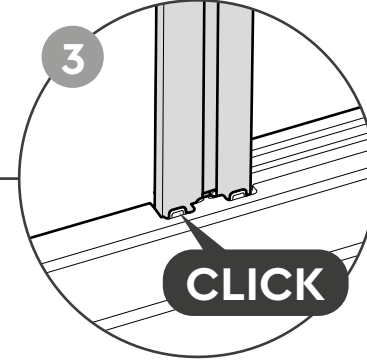
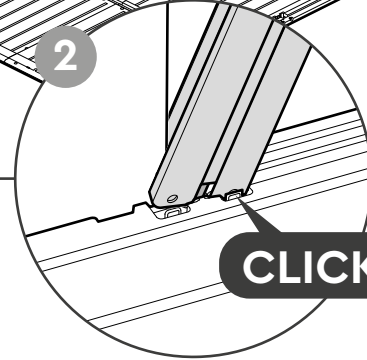
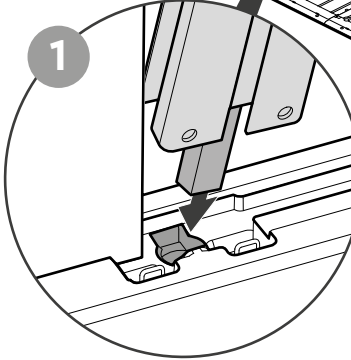
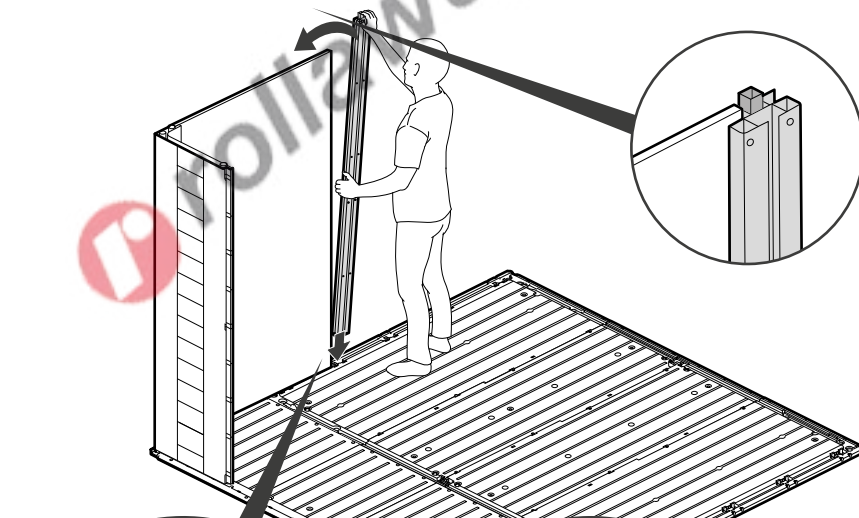
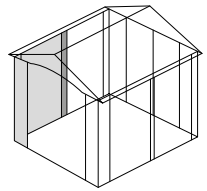



12

SPL/SPLW (x1)

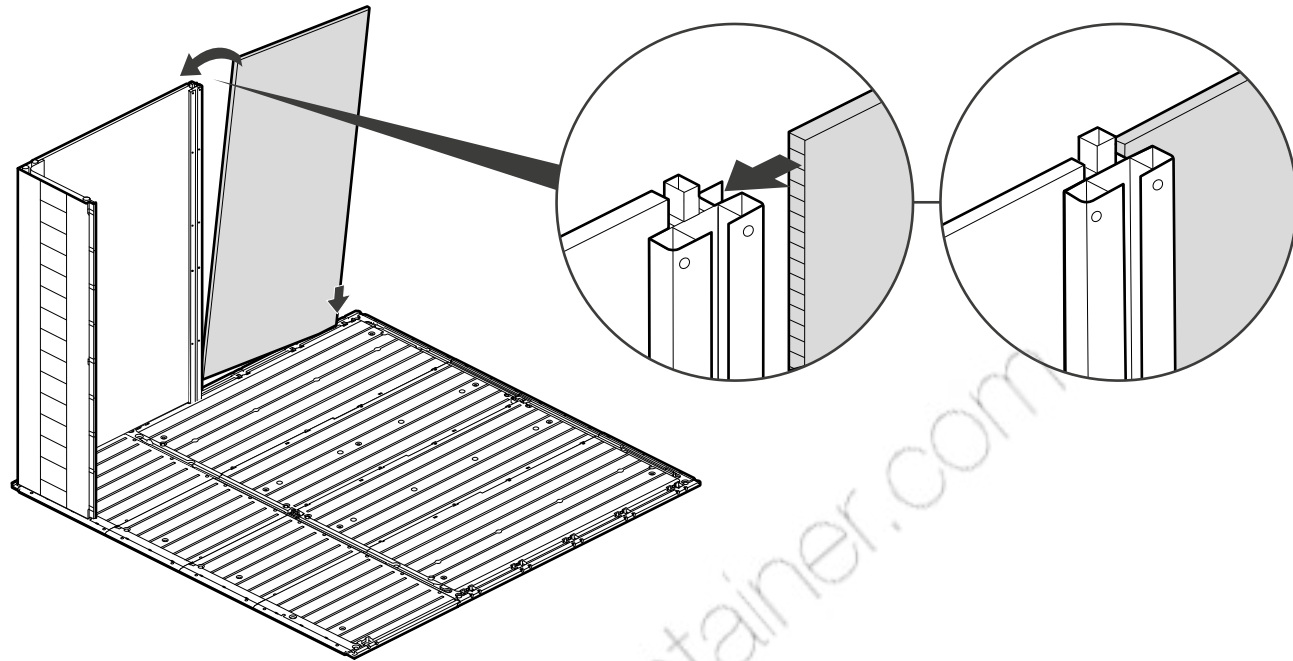
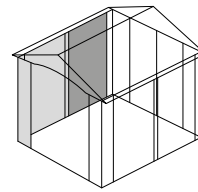

13

FCN (x1) | WA (x3) | CO (x3)

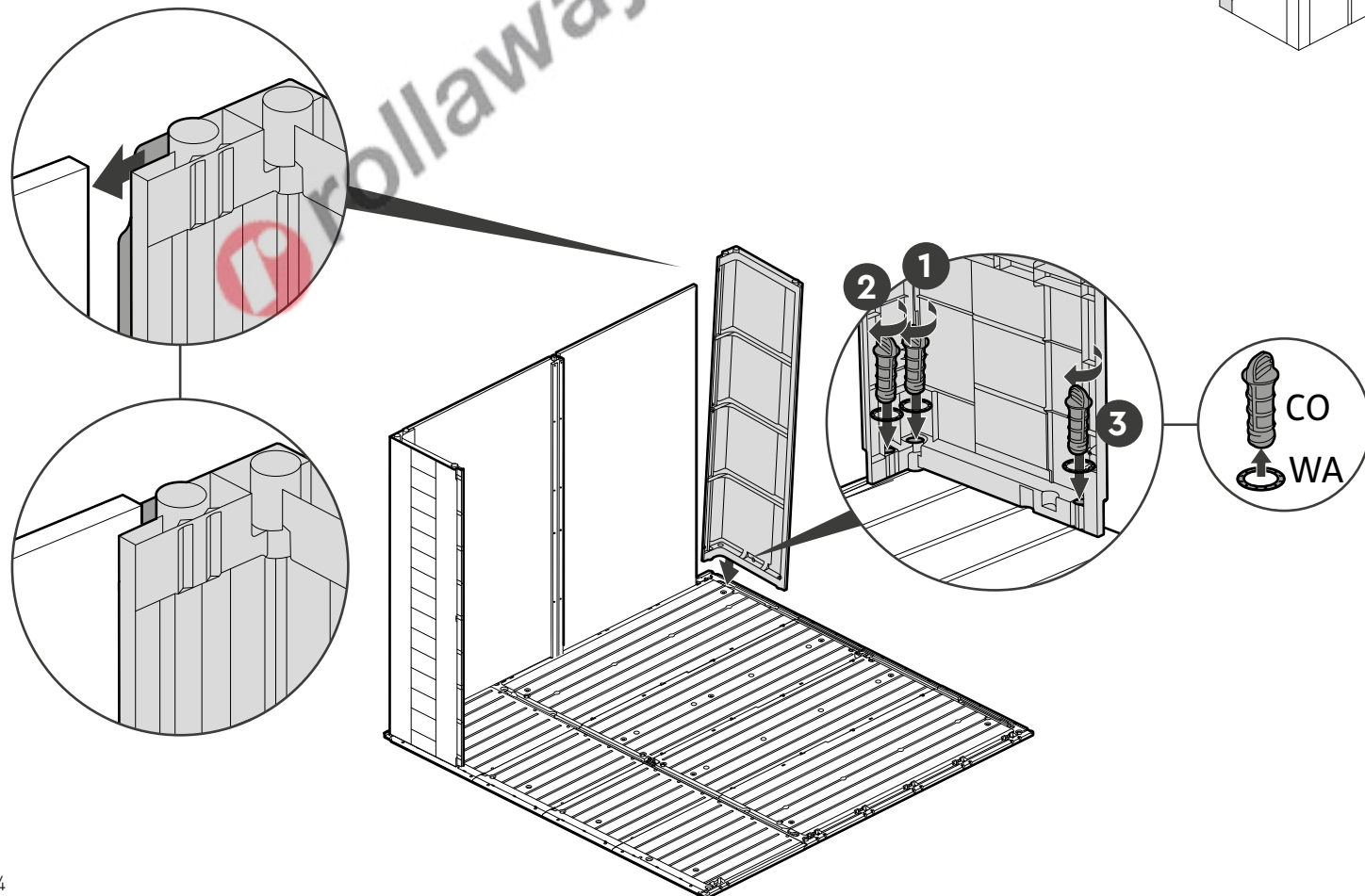
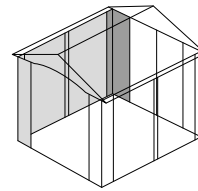

14

D88(1) (x1) | DL88(1) (x1)

DR88(1) (x1) | CO (x2) | WA (x2)

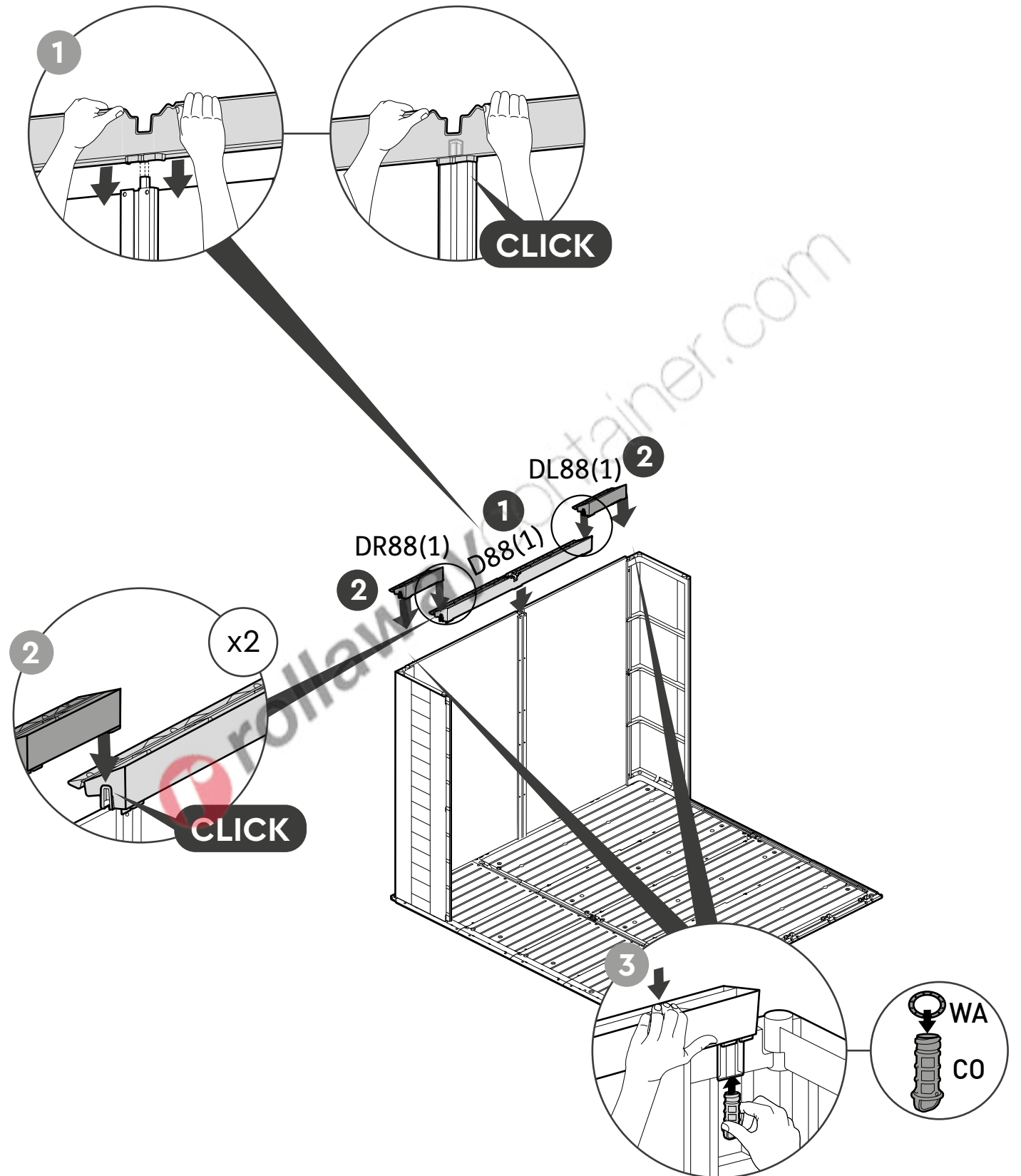
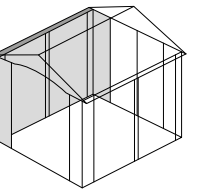

15

SP (x2)

CS+FMK (x1)

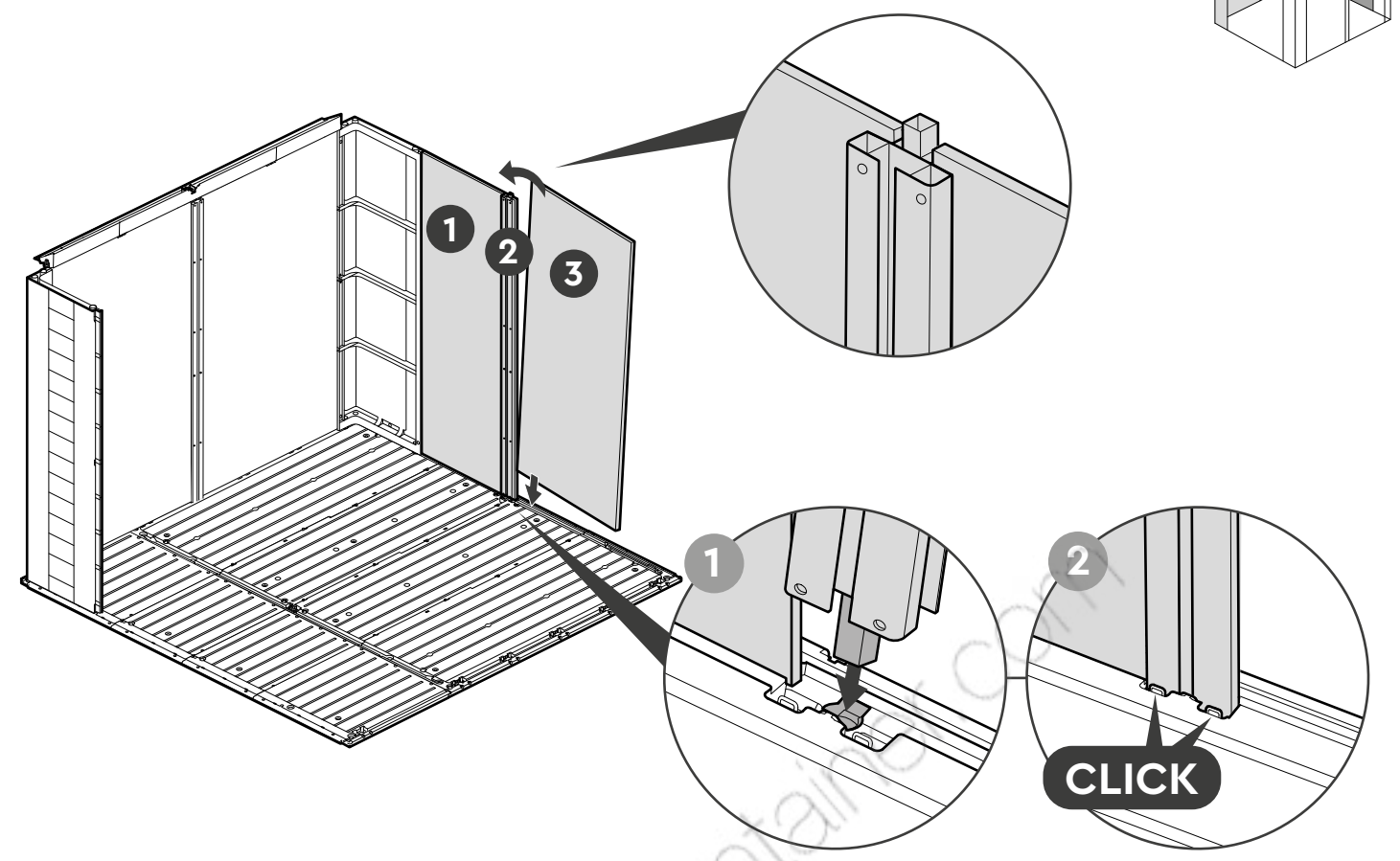
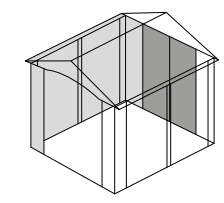

17

SPL (x1)

SPL/SPLW (x1)

CS+FMK (x1)

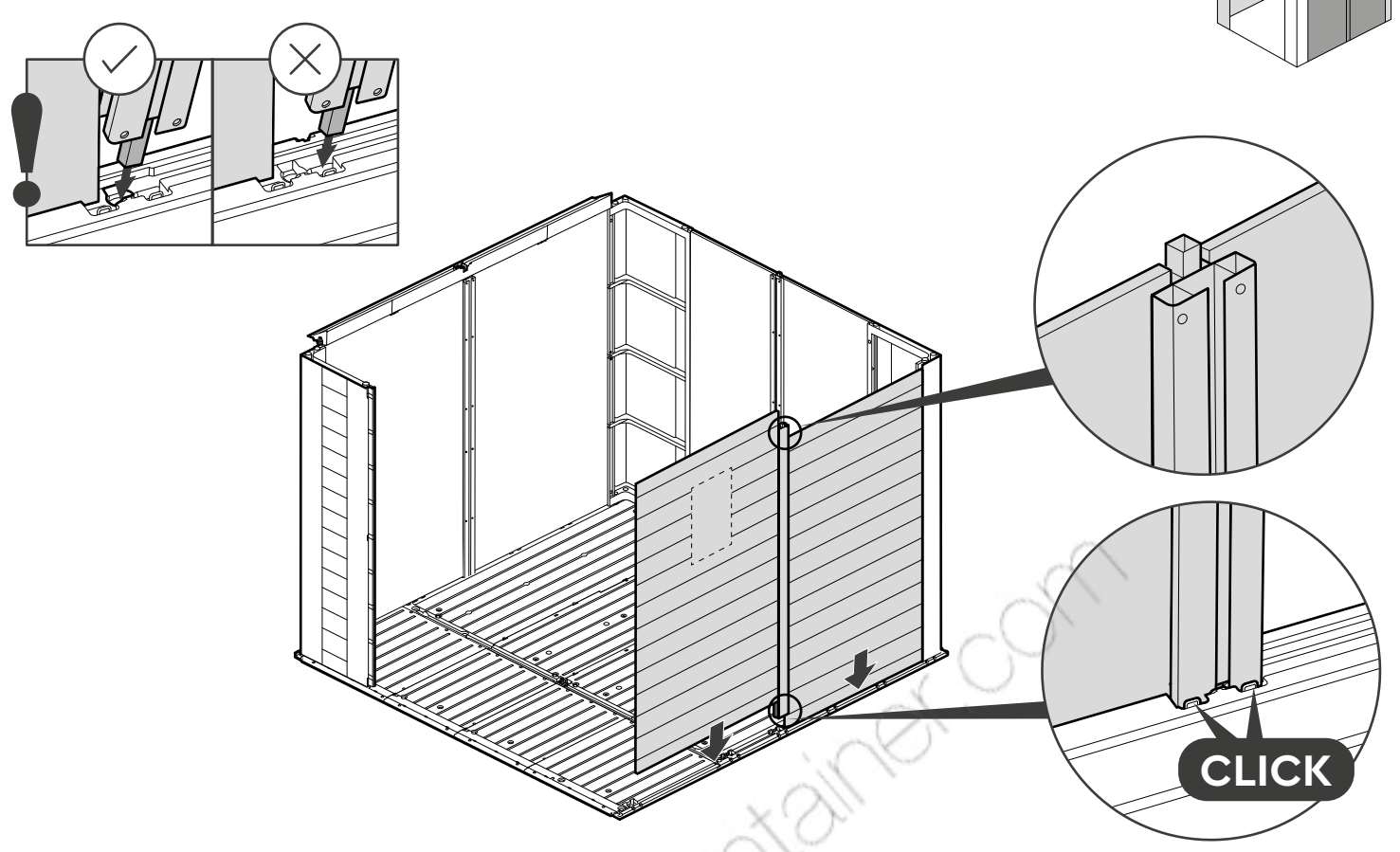
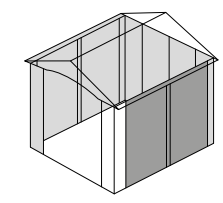

16

FCN (x1)

WA (x3)

CO (x3)

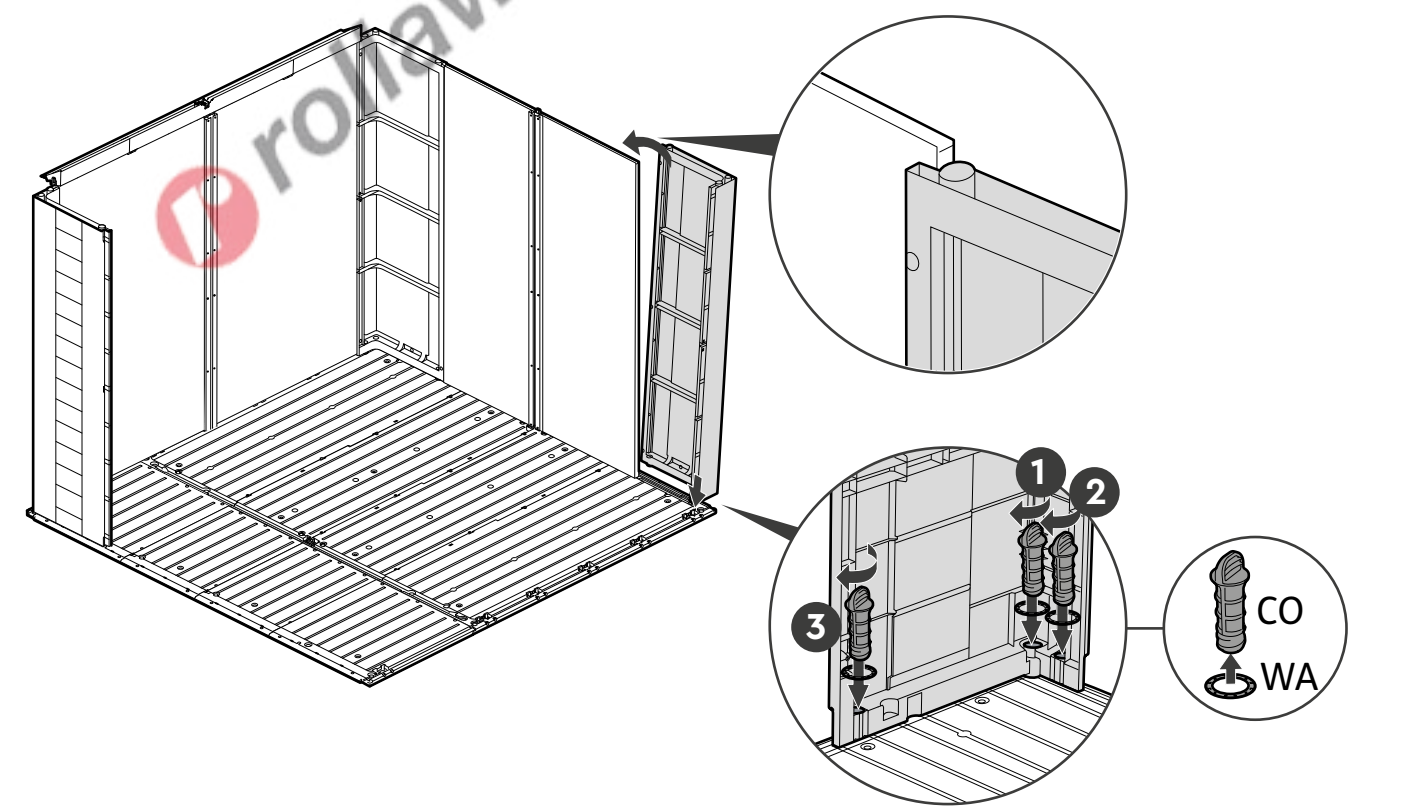
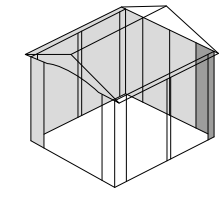

18

FCN (x1)

WA (x3)

CO (x3)

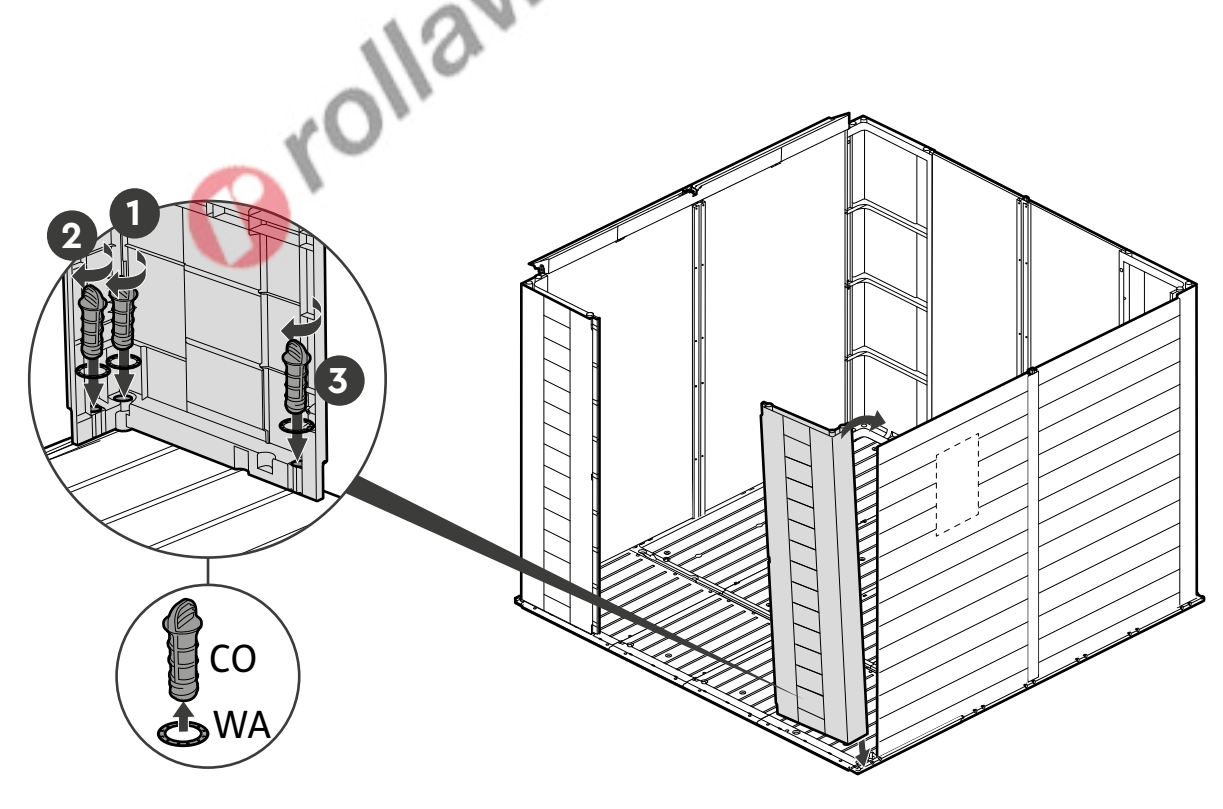
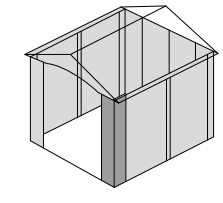



19

D88(1) (x1)

DL88(1) (x1)

DR88(1) (x1)

CO (x2)

WA (x2)

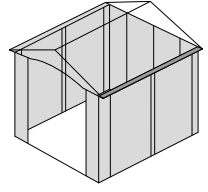

ROOF ASSEMBLY | MONTAGE DU TOIT | MONTAJE DEL TECHO | DACHMONTAGE | DAKMONTAGE | ASSEMBLAGGIO DEL TETTO | MONTAGEM DO TELHADO

20

TFB (x1)

FTV (x1)

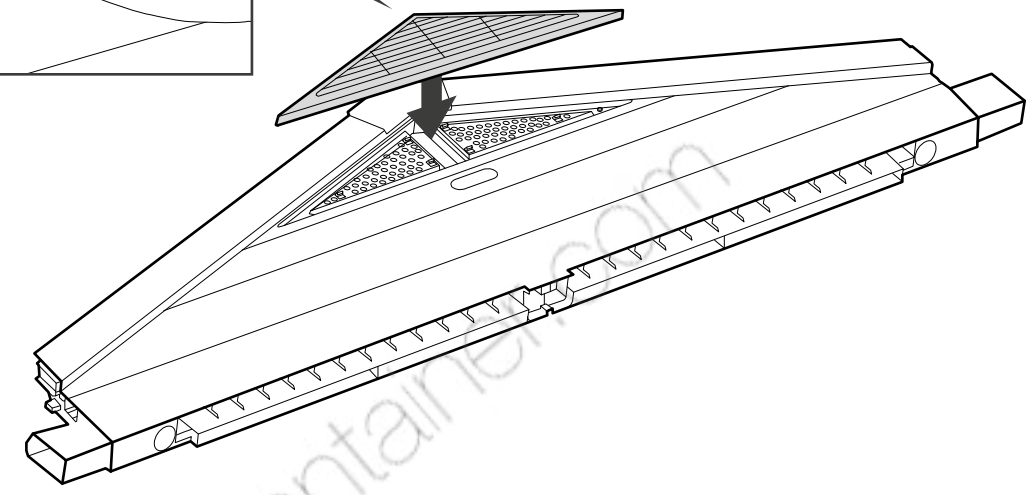
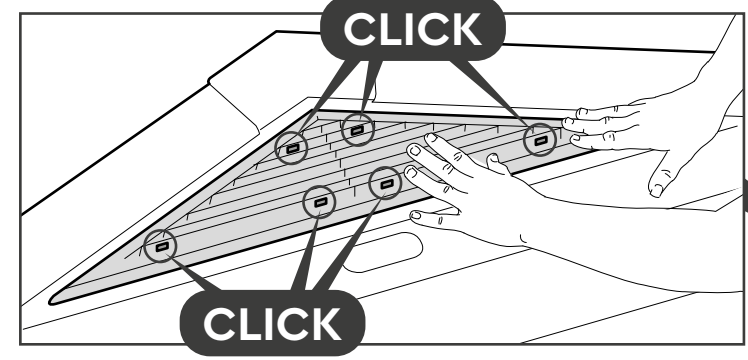
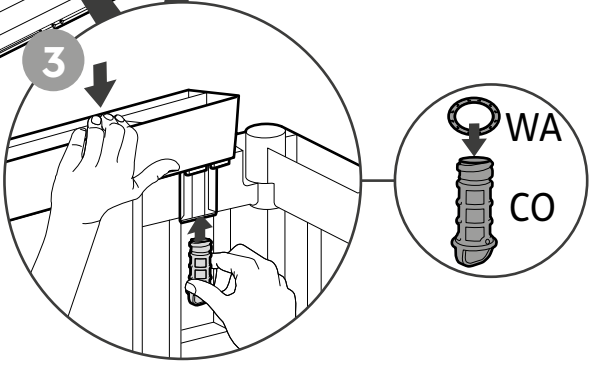
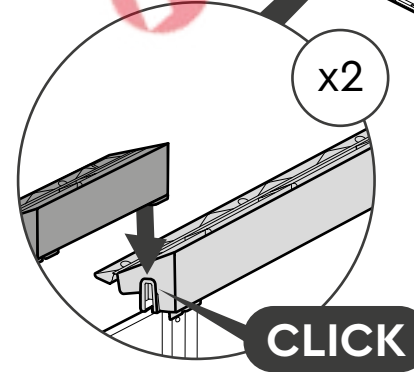
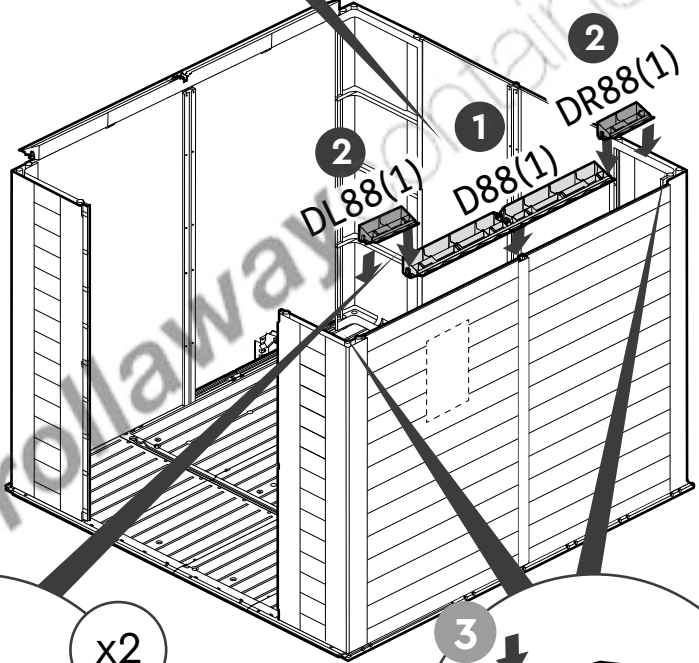
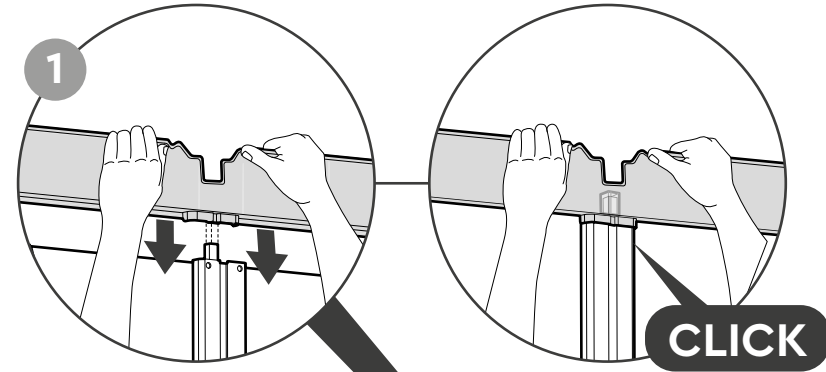
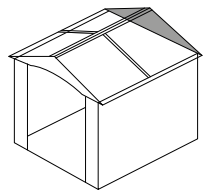

21

sc15 (x6)

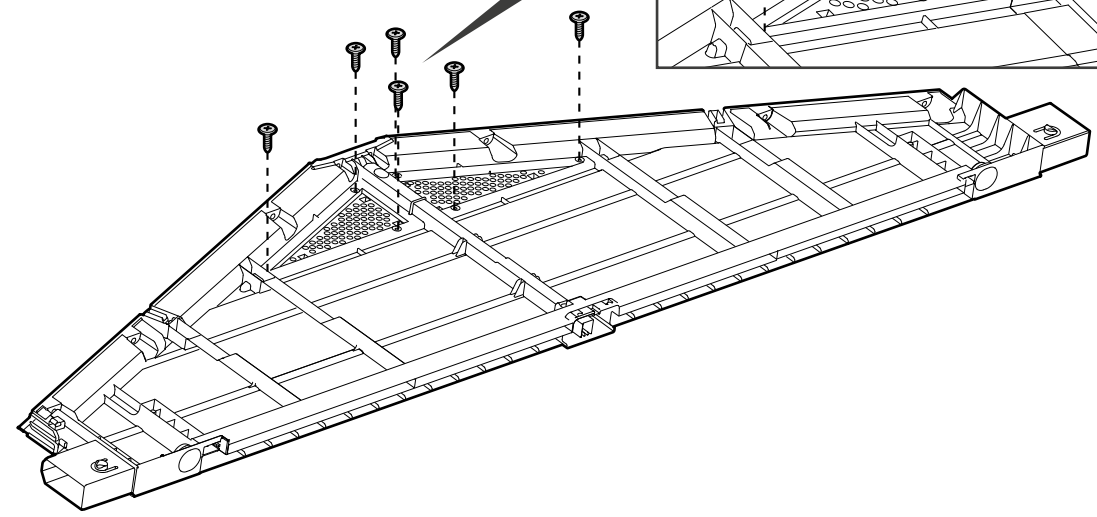
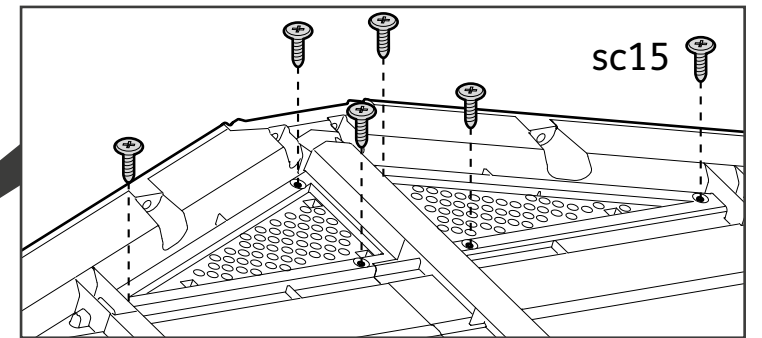
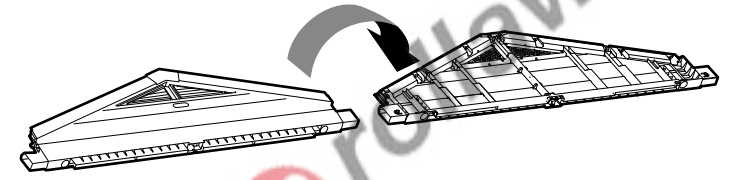
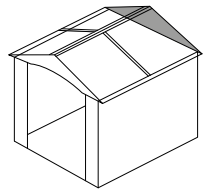



22 | TFB+FTV (x1) | TCL(1) (x1) | TCR(1) (x1)

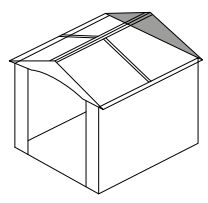
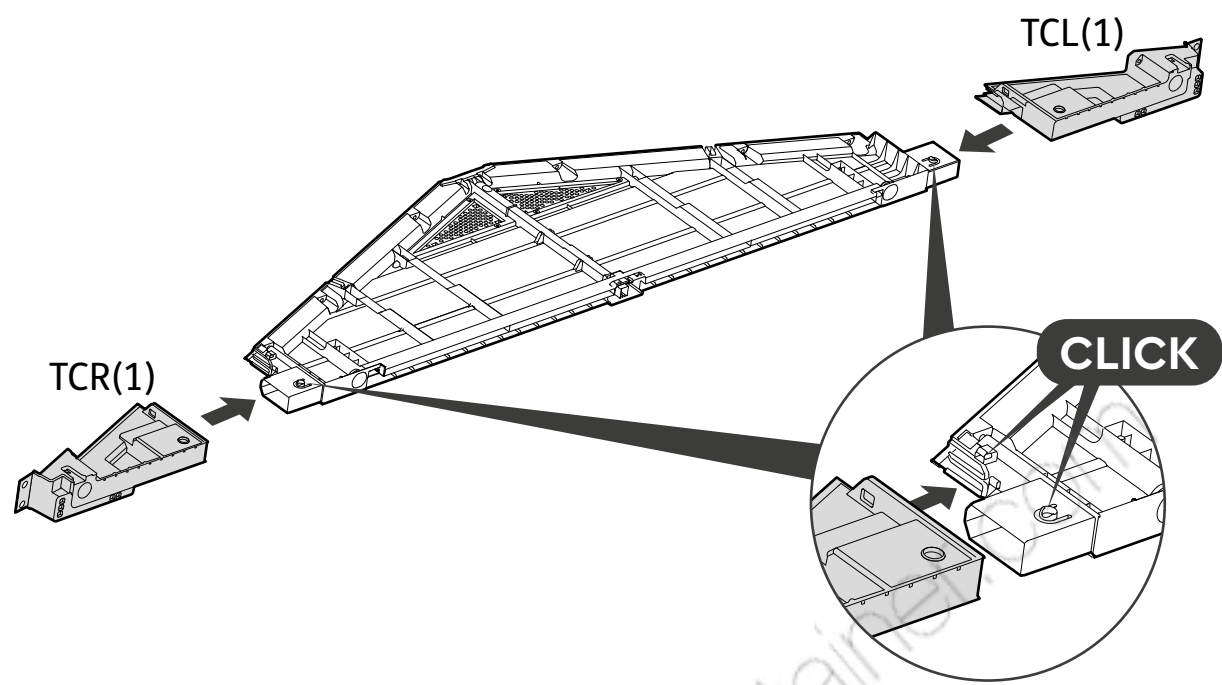

24 | FBT (x1) | sc15 (x1)

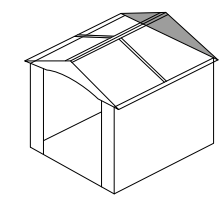
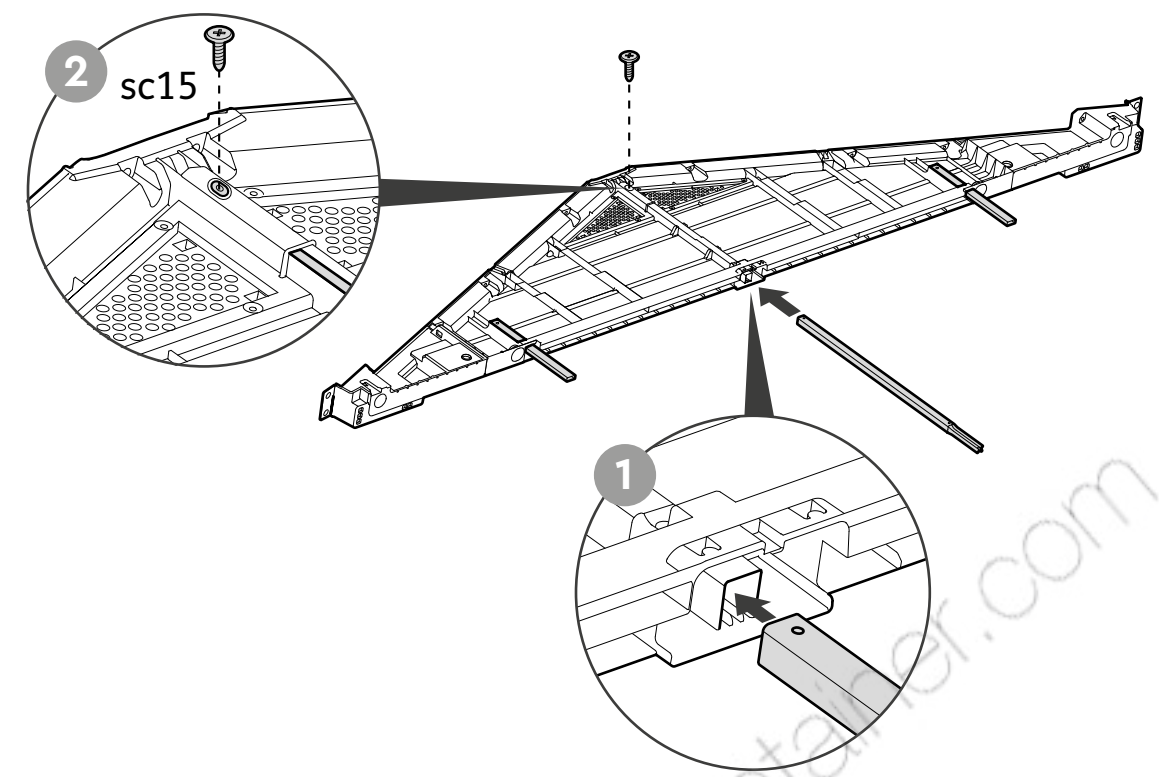

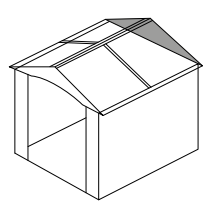
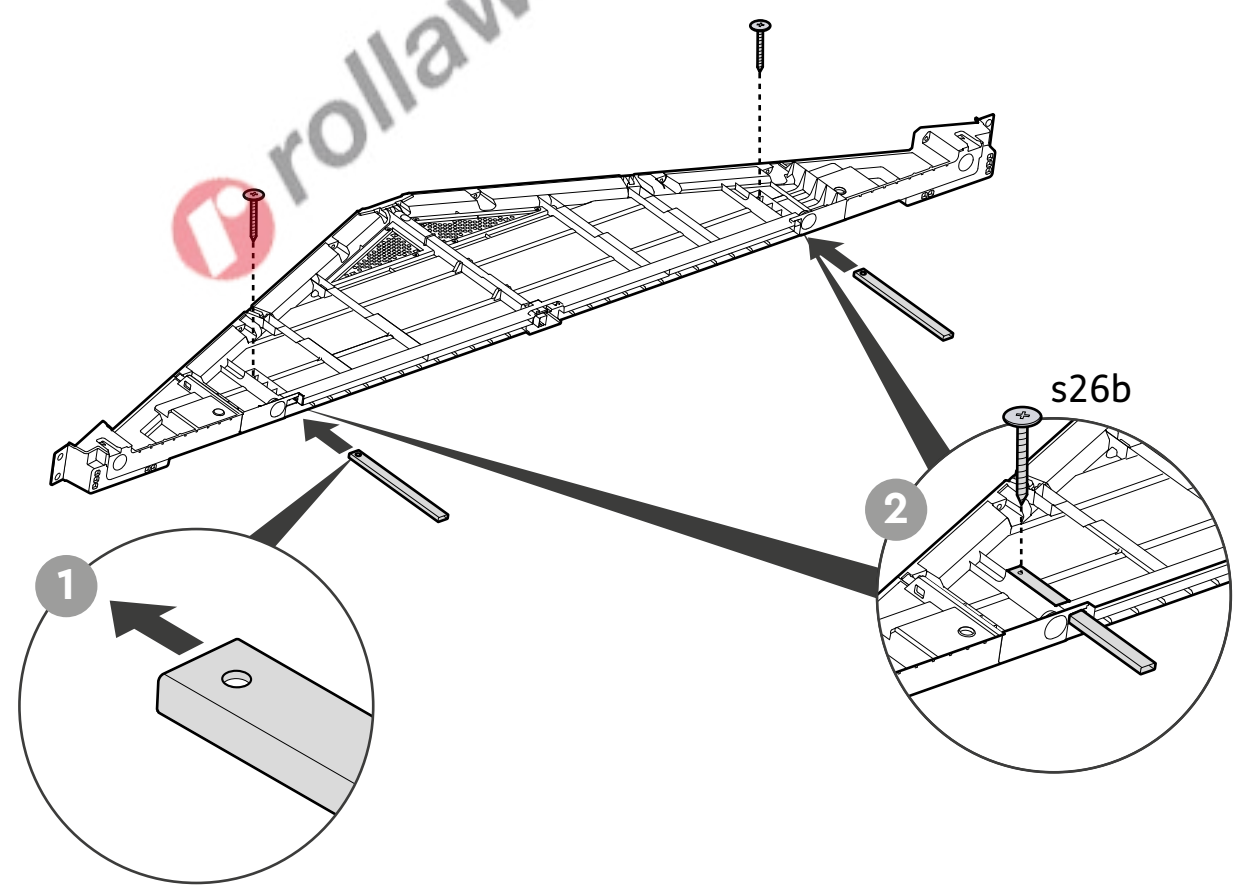

23 | FTS (x2) | s26b (x2)



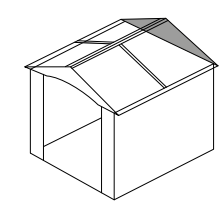
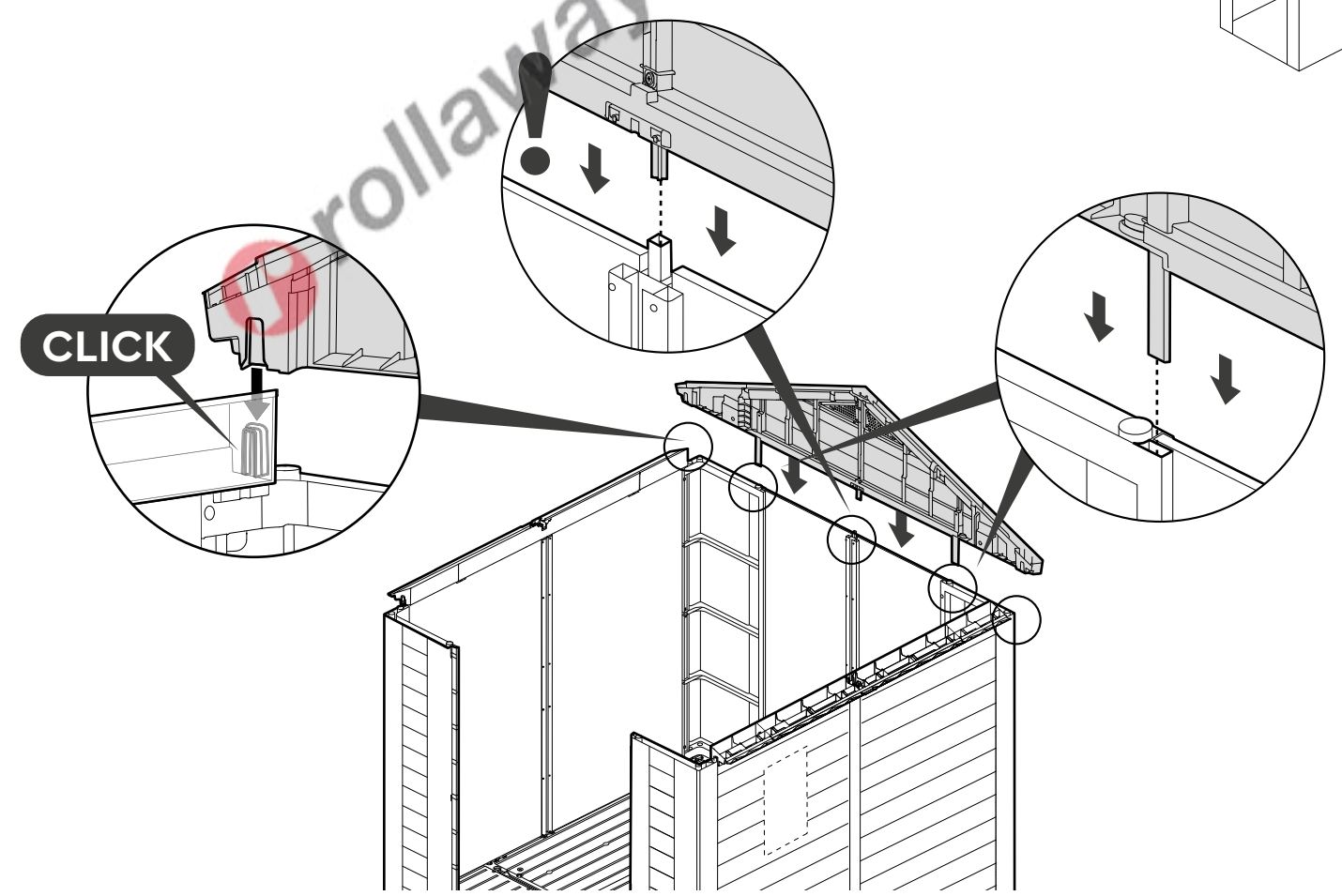

25



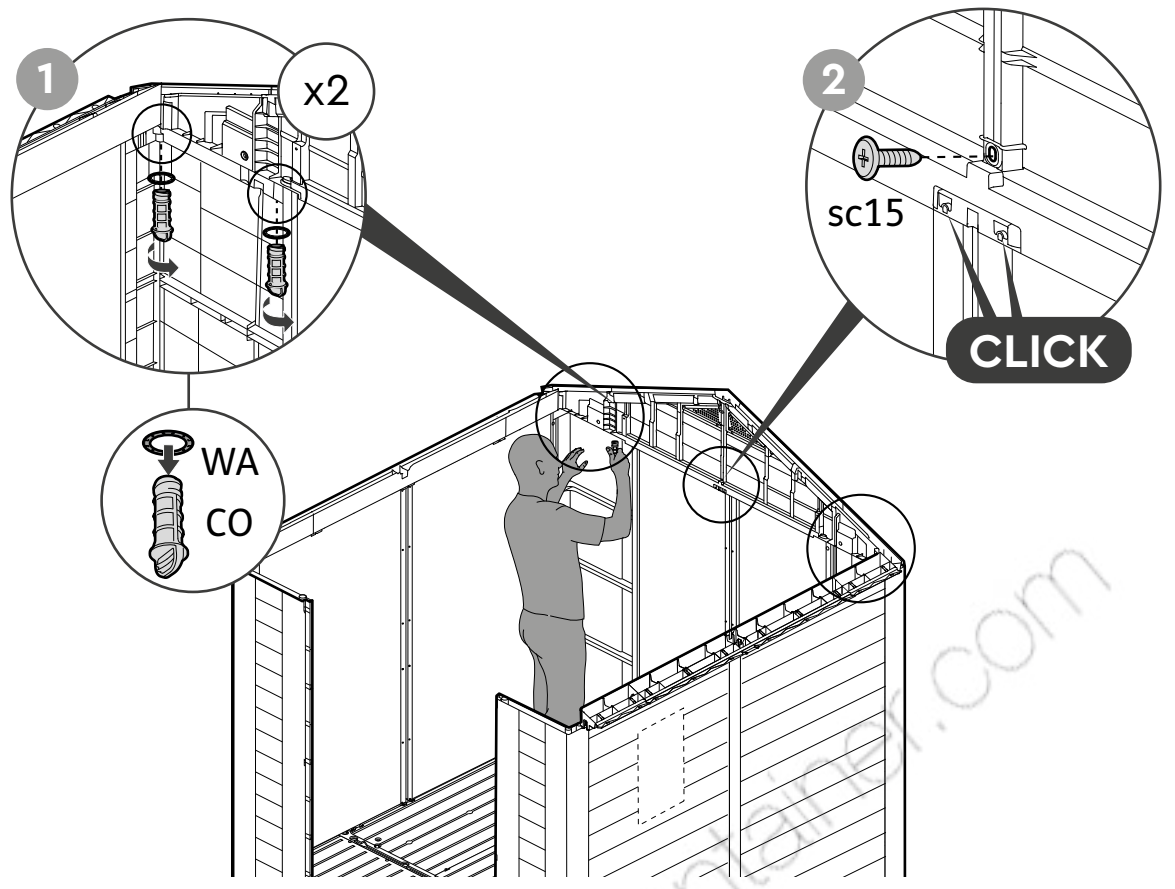
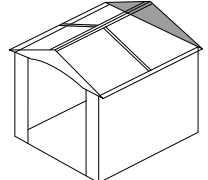



- 26 |  CO (x4) |  WA (x4) |  sc15 (x1)

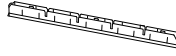

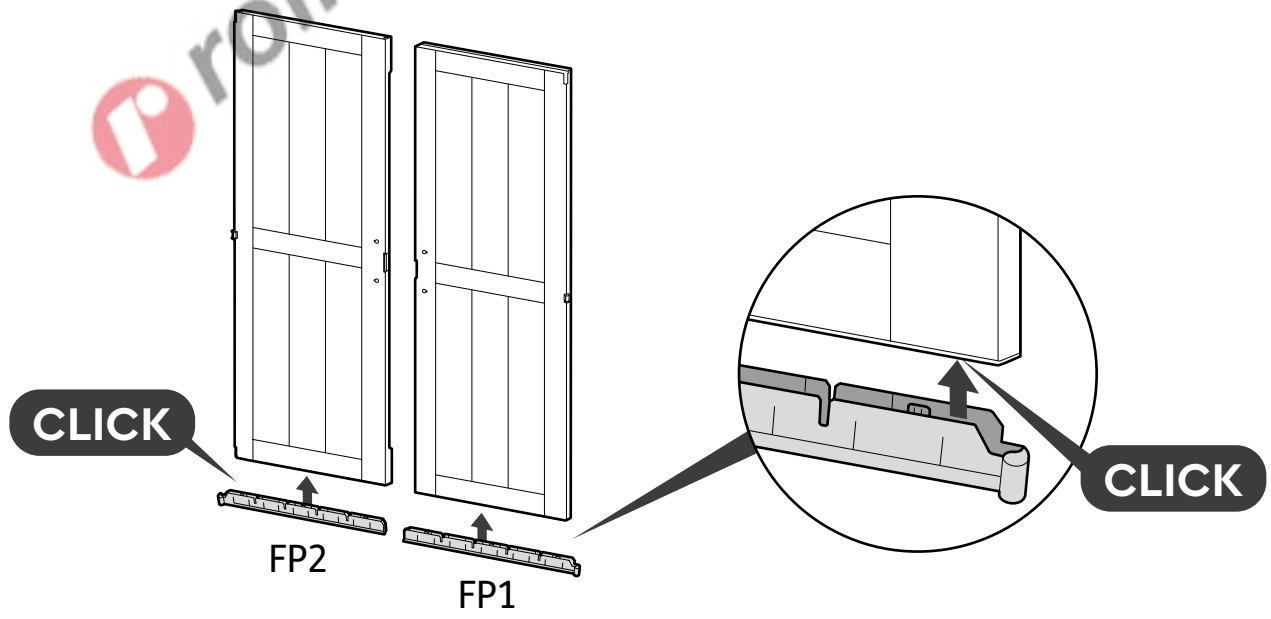
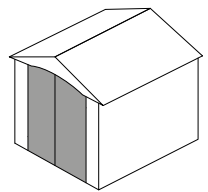

DOOR ASSEMBLY | MONTAGE DE LA PORTE | ARMADO DE LA PUERTA | MONTAGE DER TÜR | DEURMONTAGE | ASSEMBLAGGIO DELLA PORTA | MONTAGEM DA PORTA

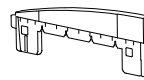
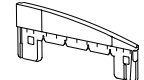
- 27 |  FFD (x2) |  FP2 (x1) |  FP1 (x1)

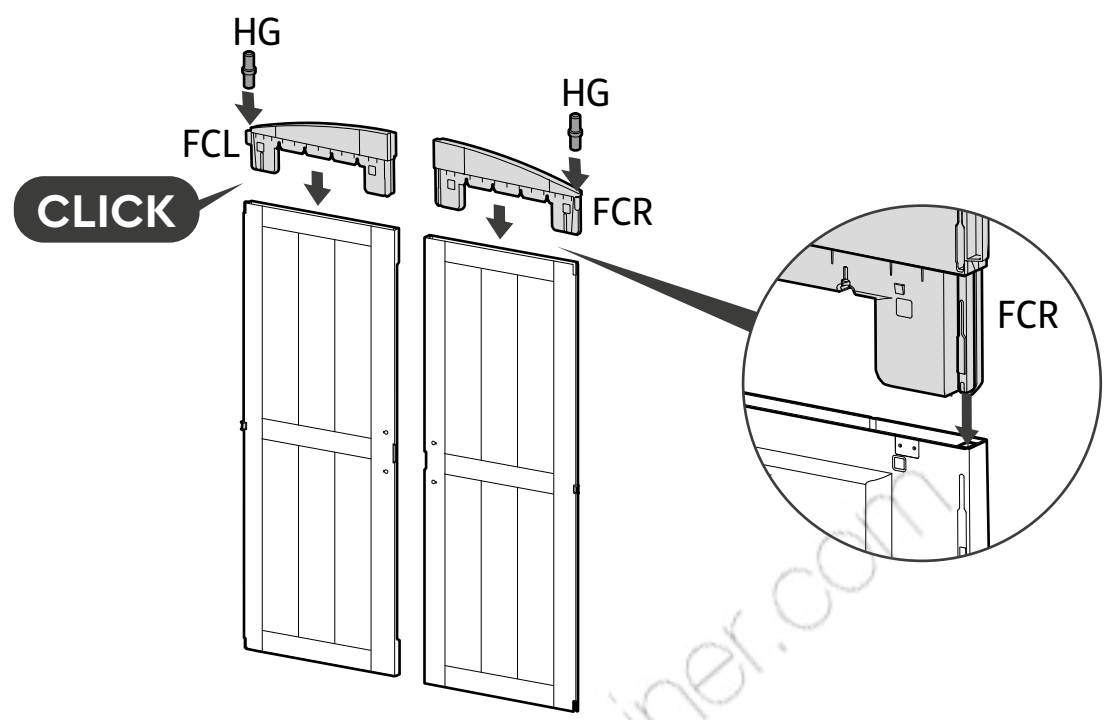
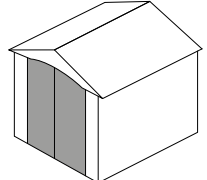

- 28 |  FFD (x2) |  FCL (x1) |  FCR (x1) |  HG (x2)



- 29 |  FHD (x2)

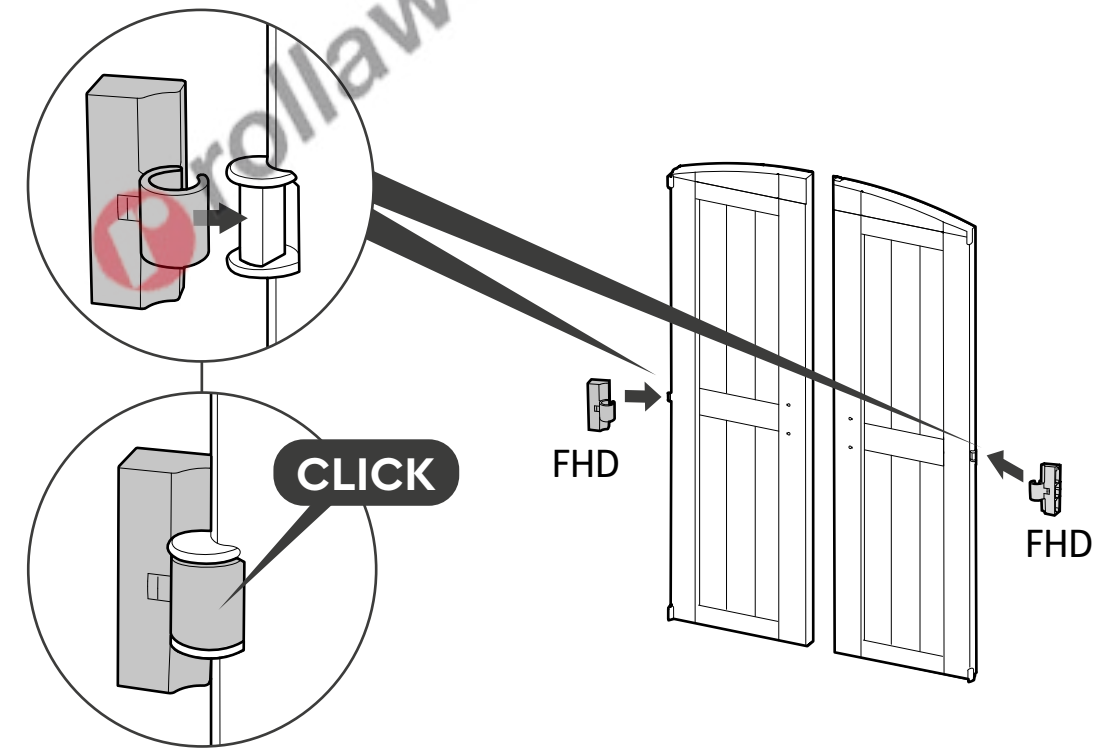
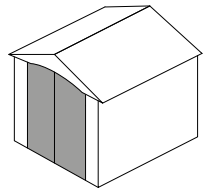

30

HG (x2)

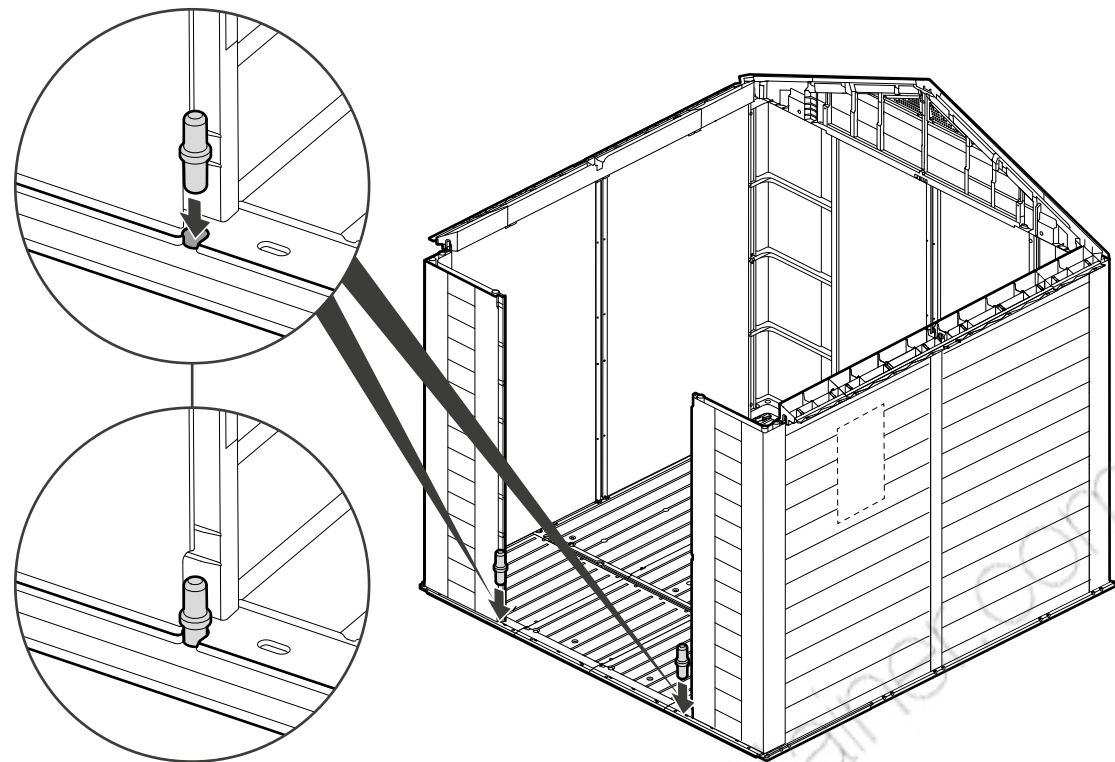
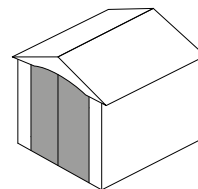

31

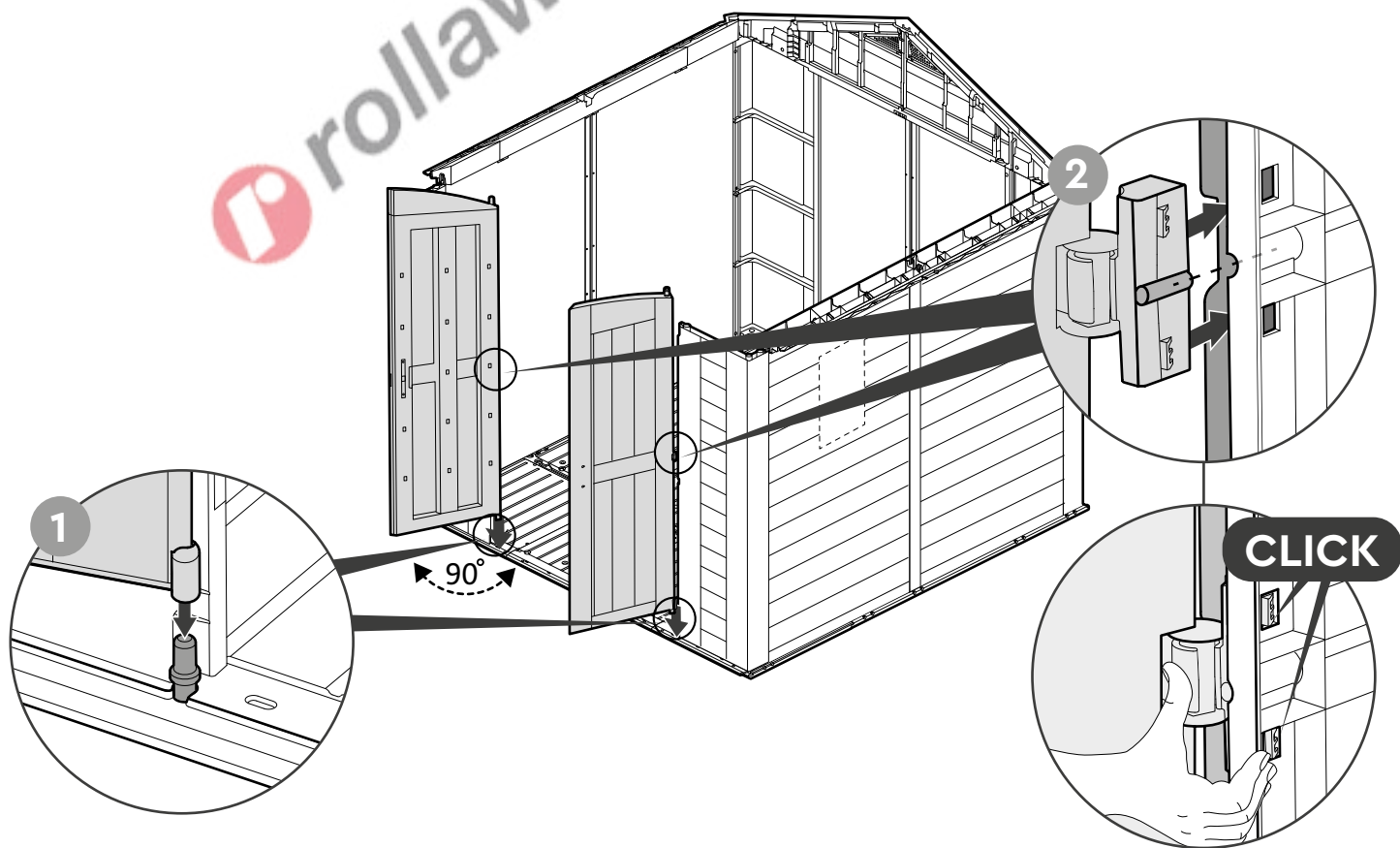
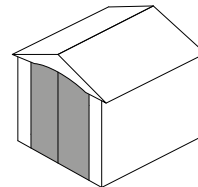

ROOF ASSEMBLY | MONTAGE DU TOIT | MONTAJE DEL TECHO | DACHMONTAGE | DAKMONTAGE | ASSEMBLAGGIO DEL TETTO | MONTAGEM DO TELHADO

32

TFF (x1)

FTV (x1)

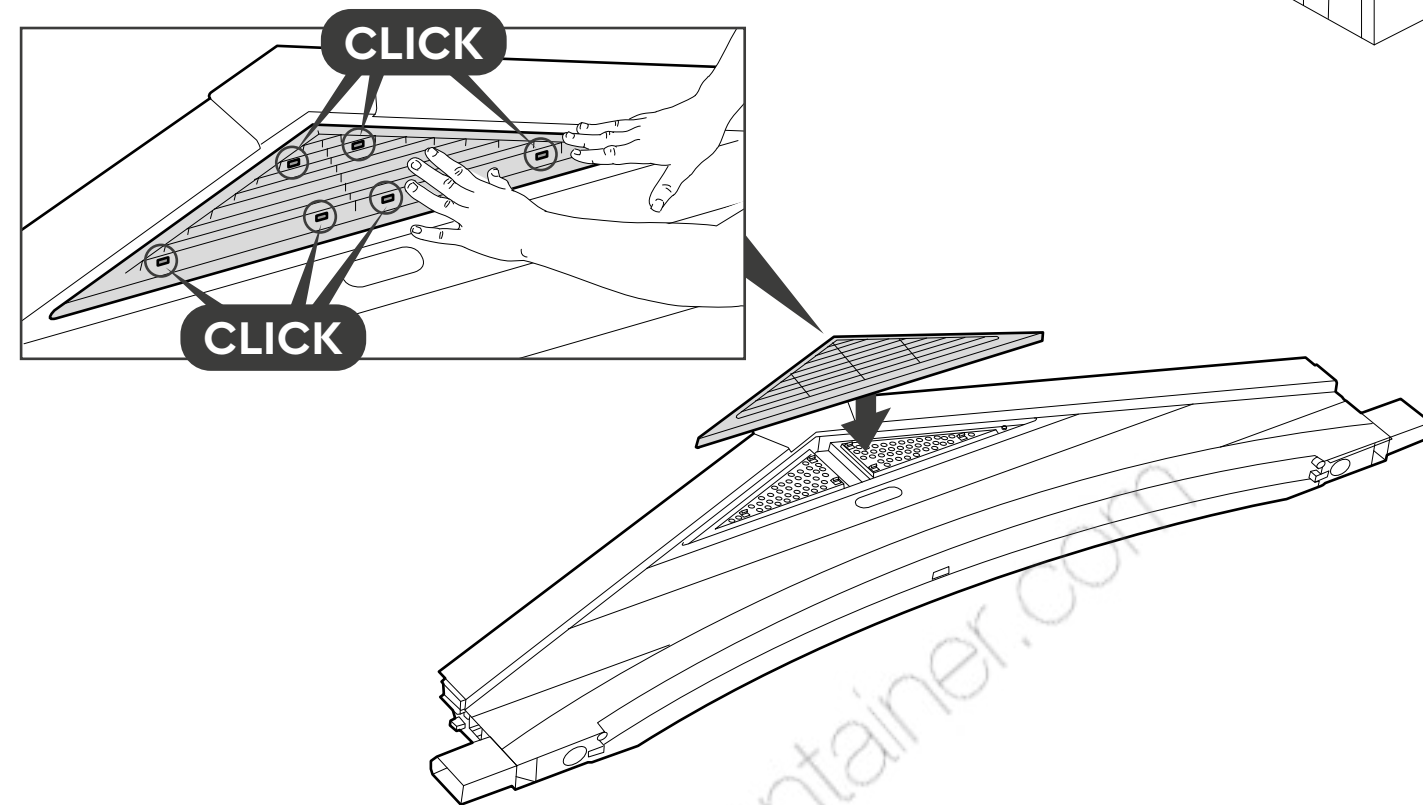
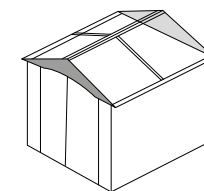

33

TFF+FTV (x1)

sc15 (x6)

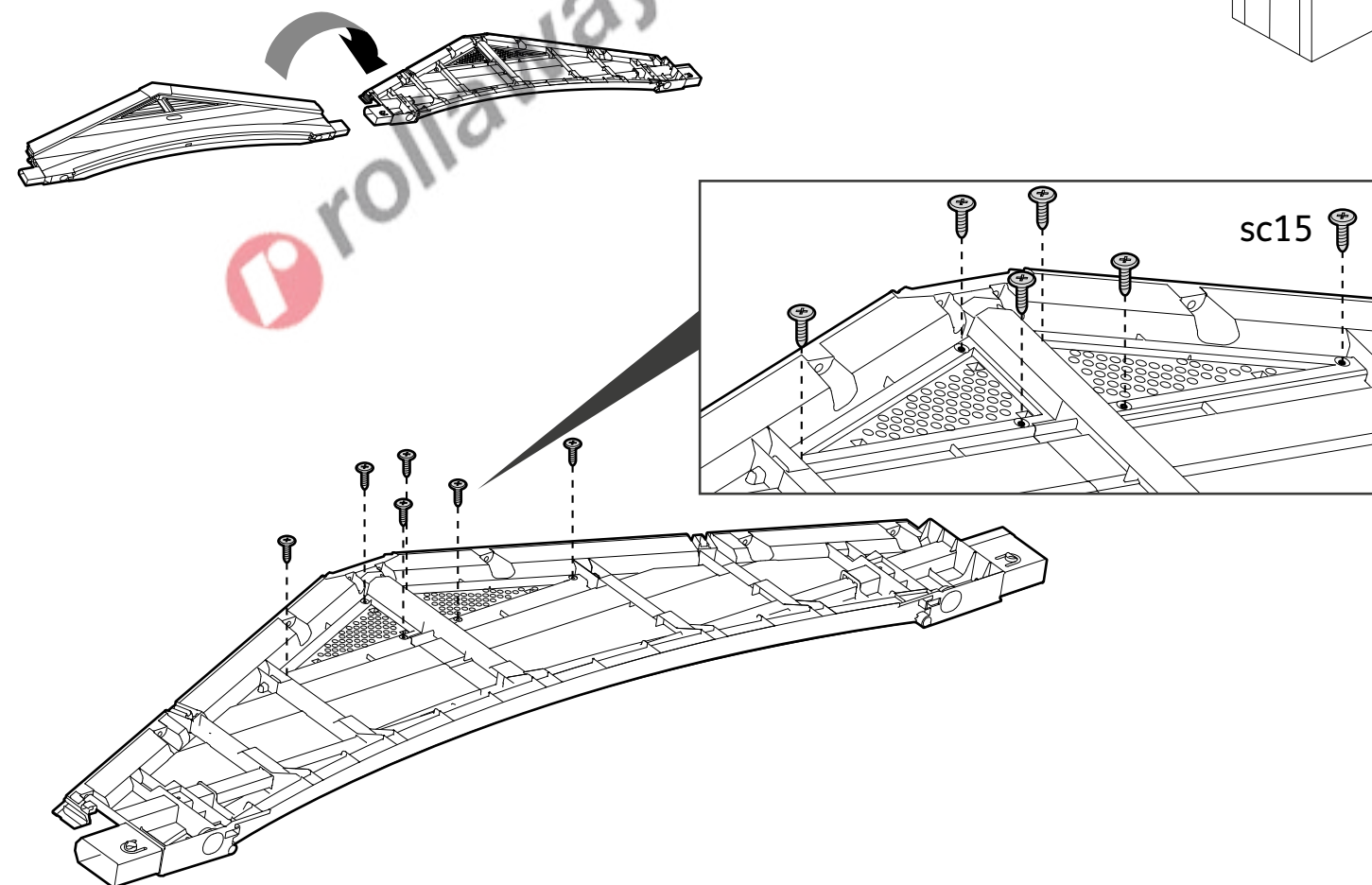
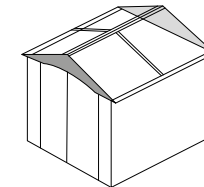



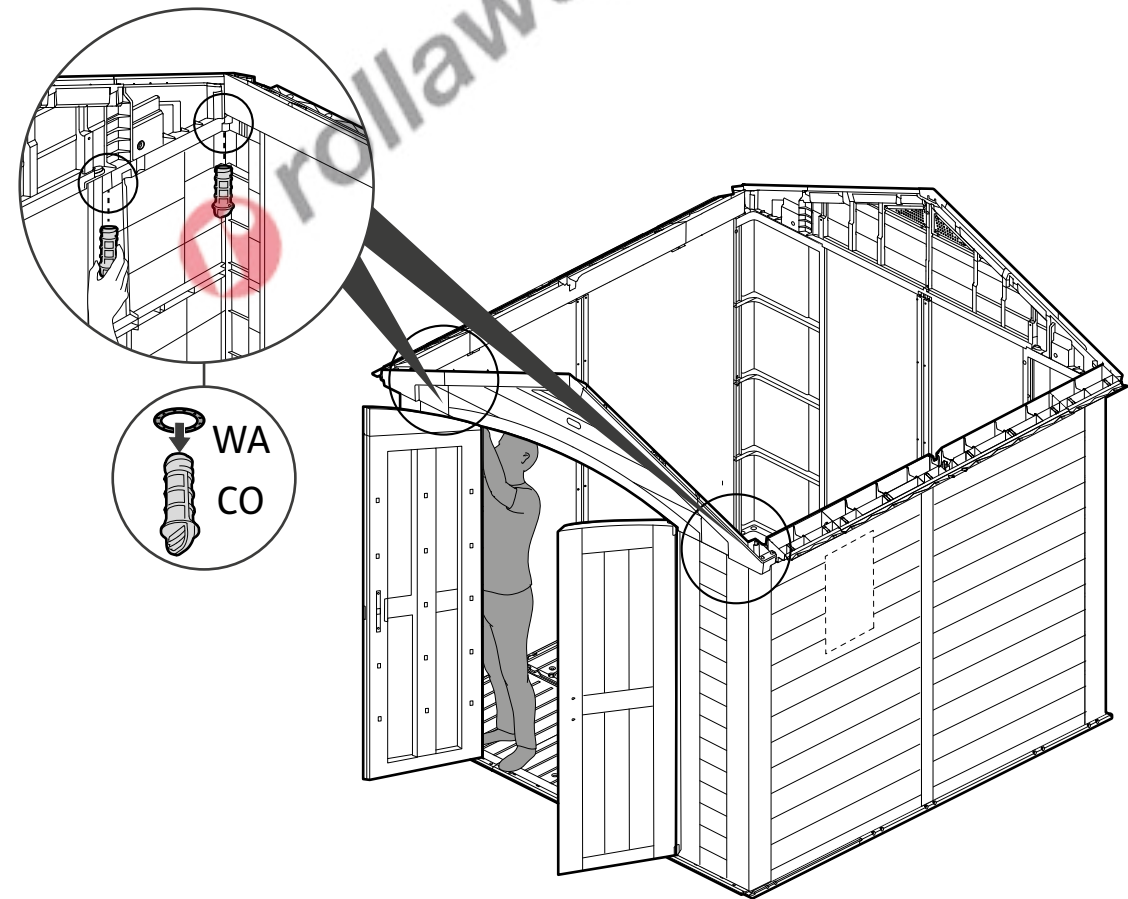
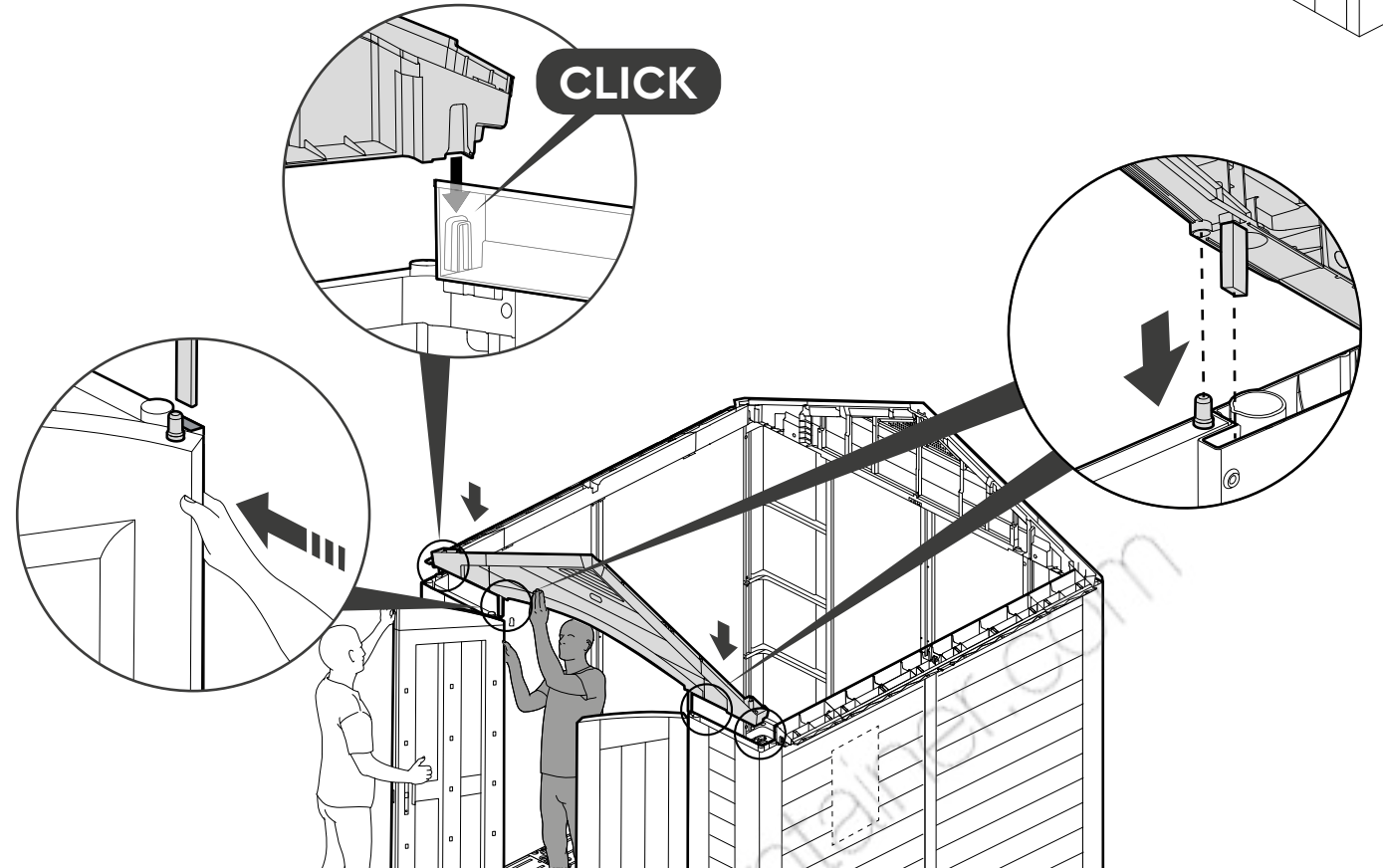
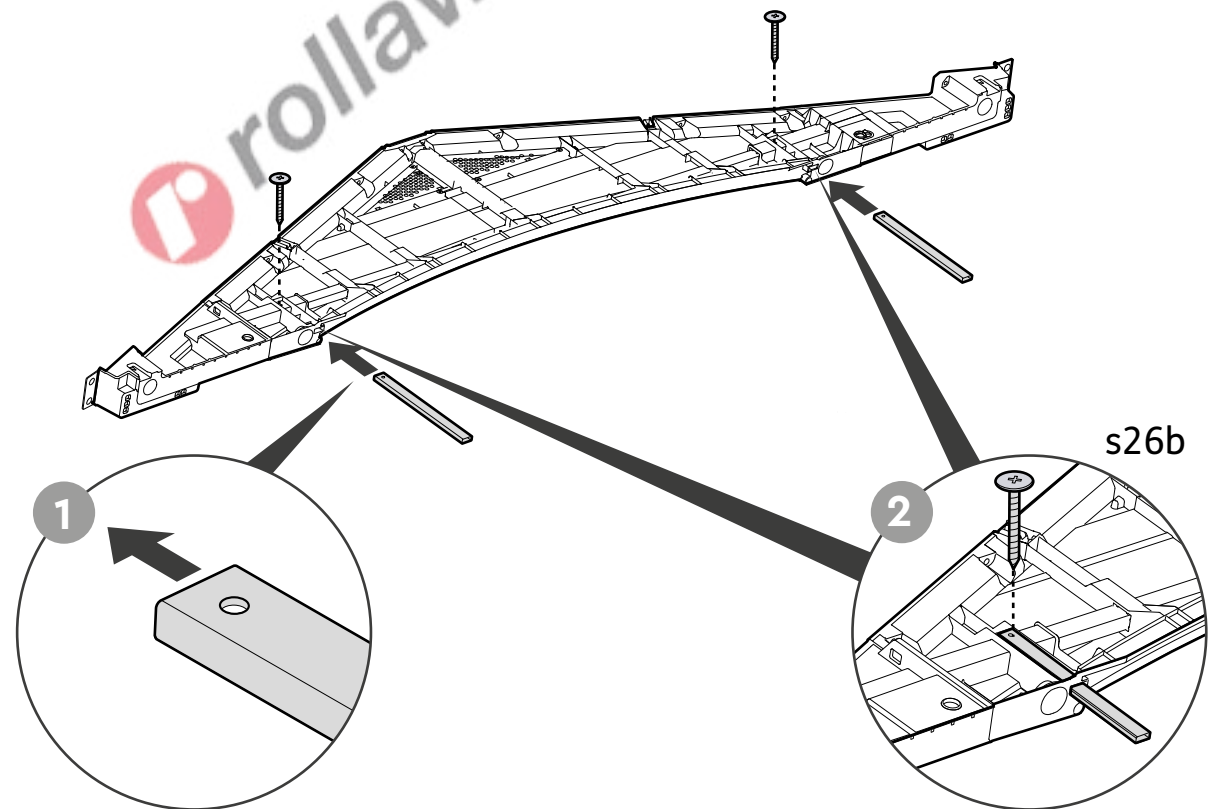
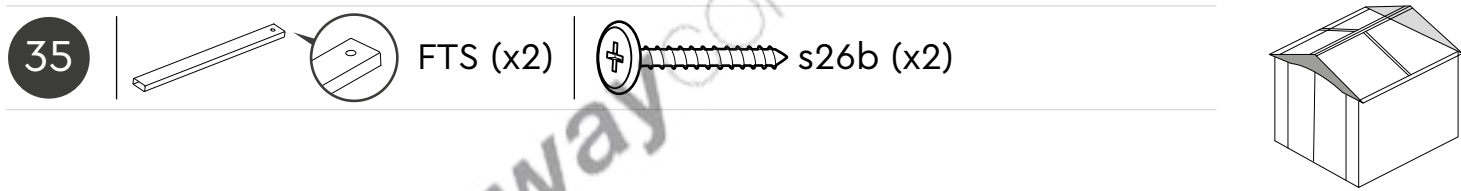
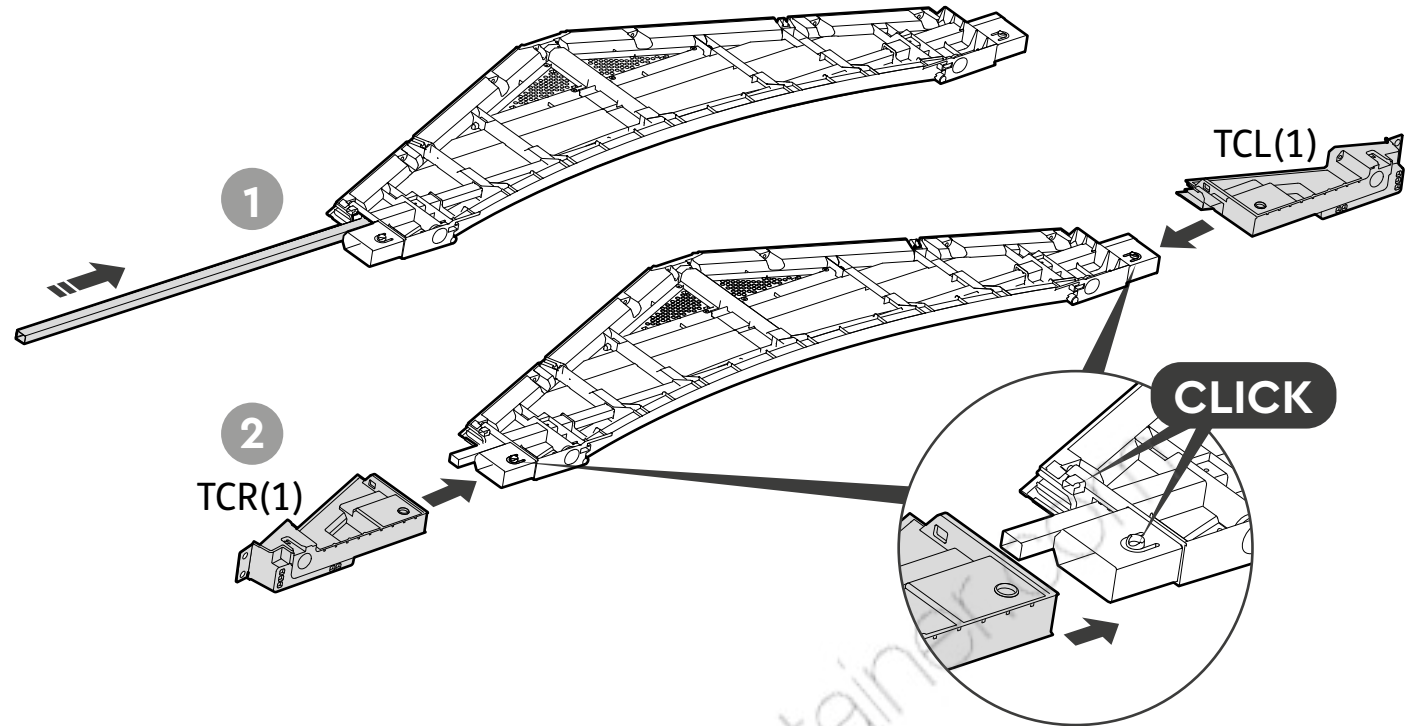
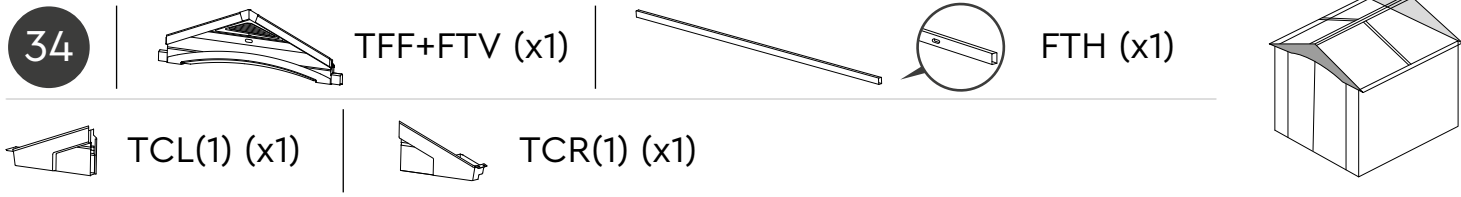

38

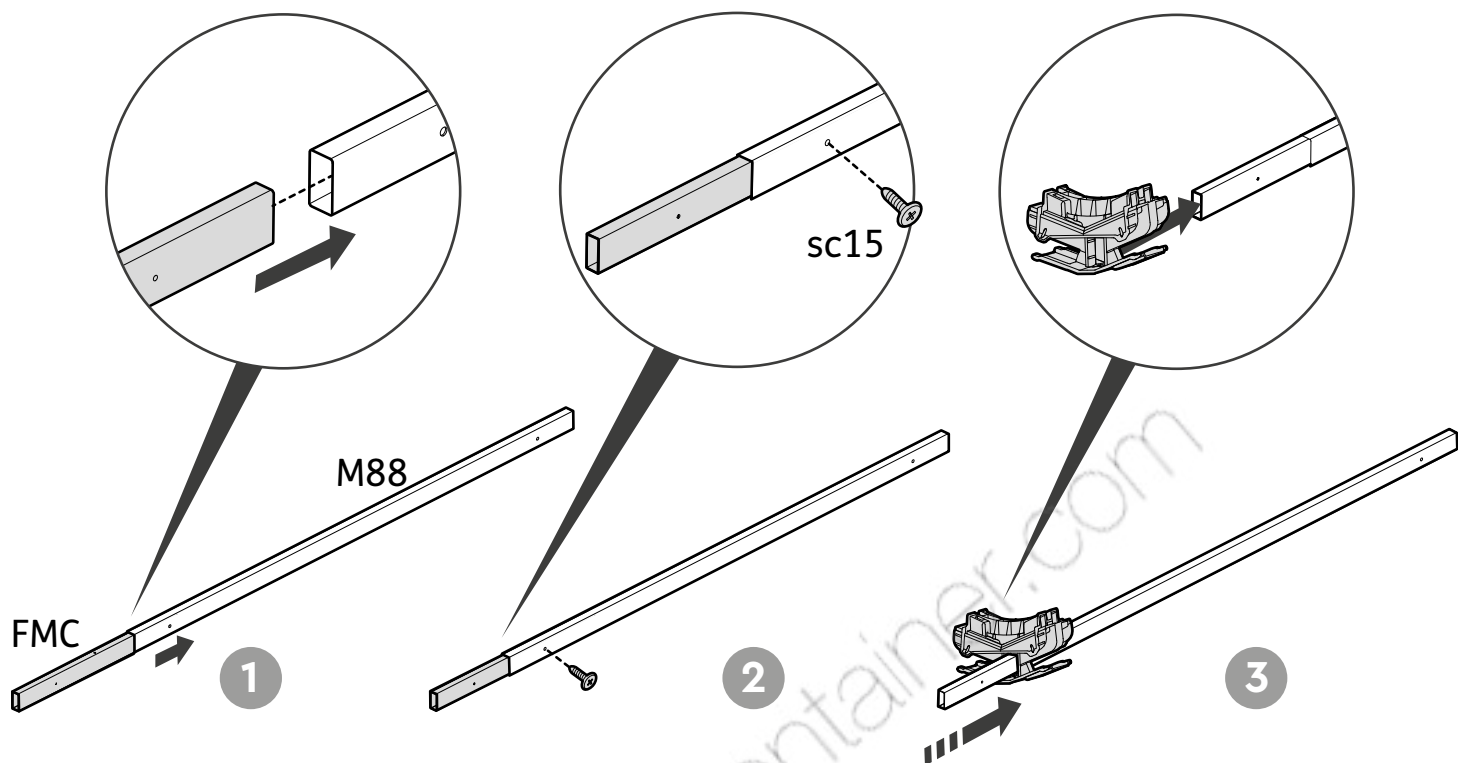
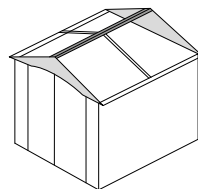
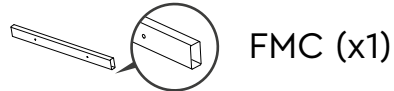
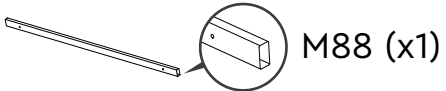

39

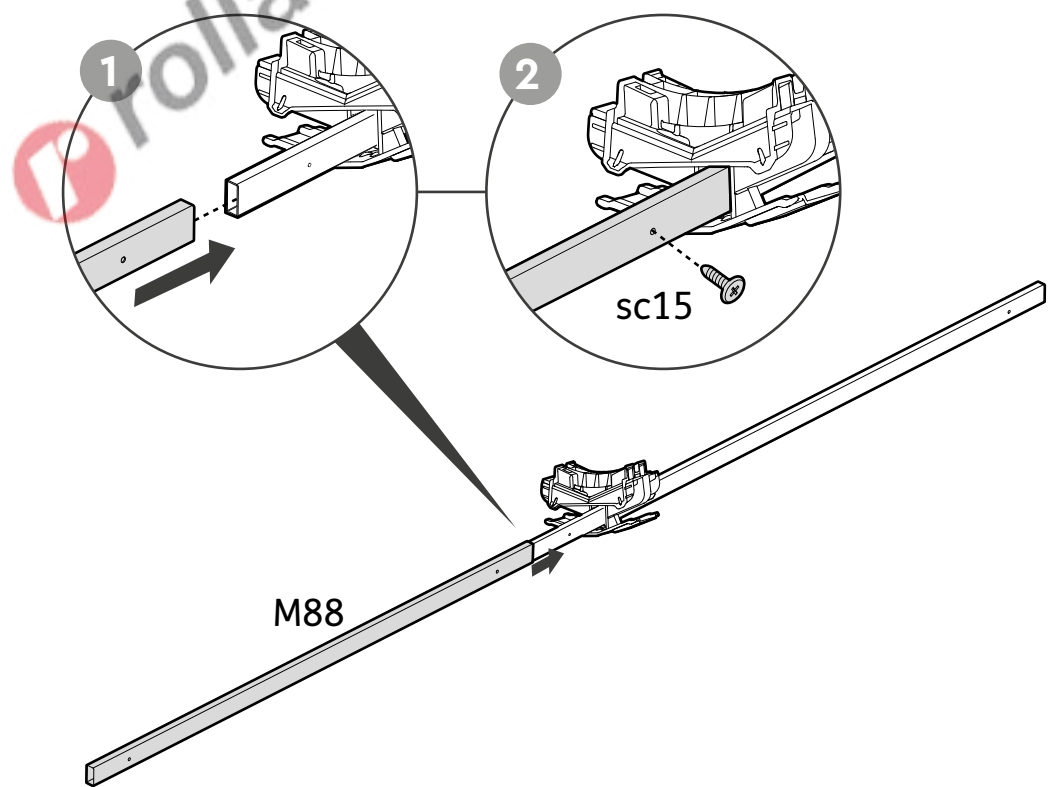
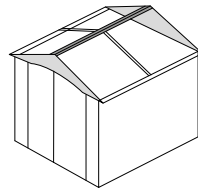

40

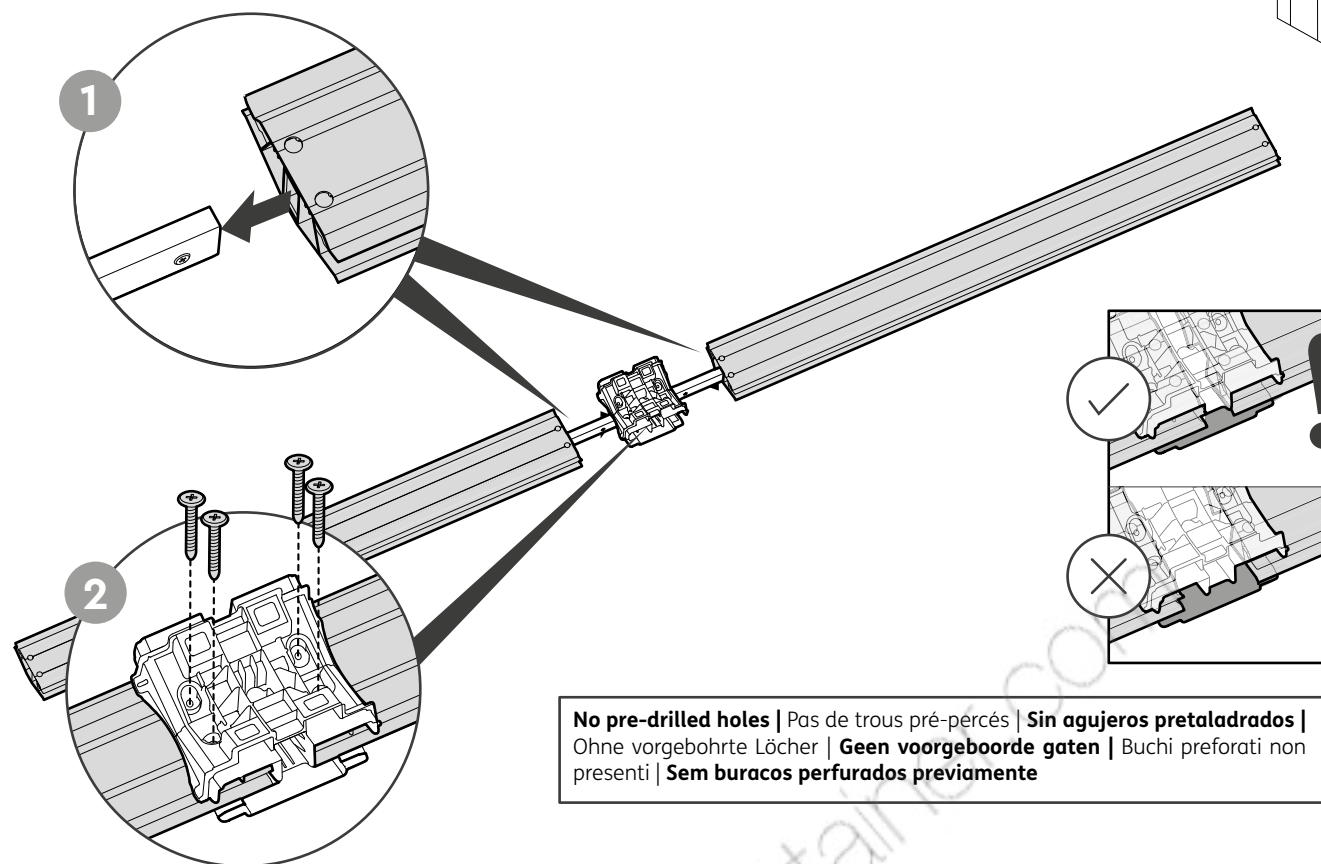
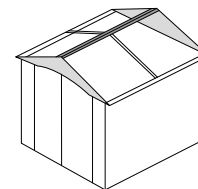

**No pre-drilled holes | Pas de trous pré-perçés | Sin agujeros pretaladrados |**  
 Ohne vorgebohrte Löcher | **Geen voorgeboorde gaten** | Buchi perforati non presenti | **Sem buracos perfurados previamente**

41

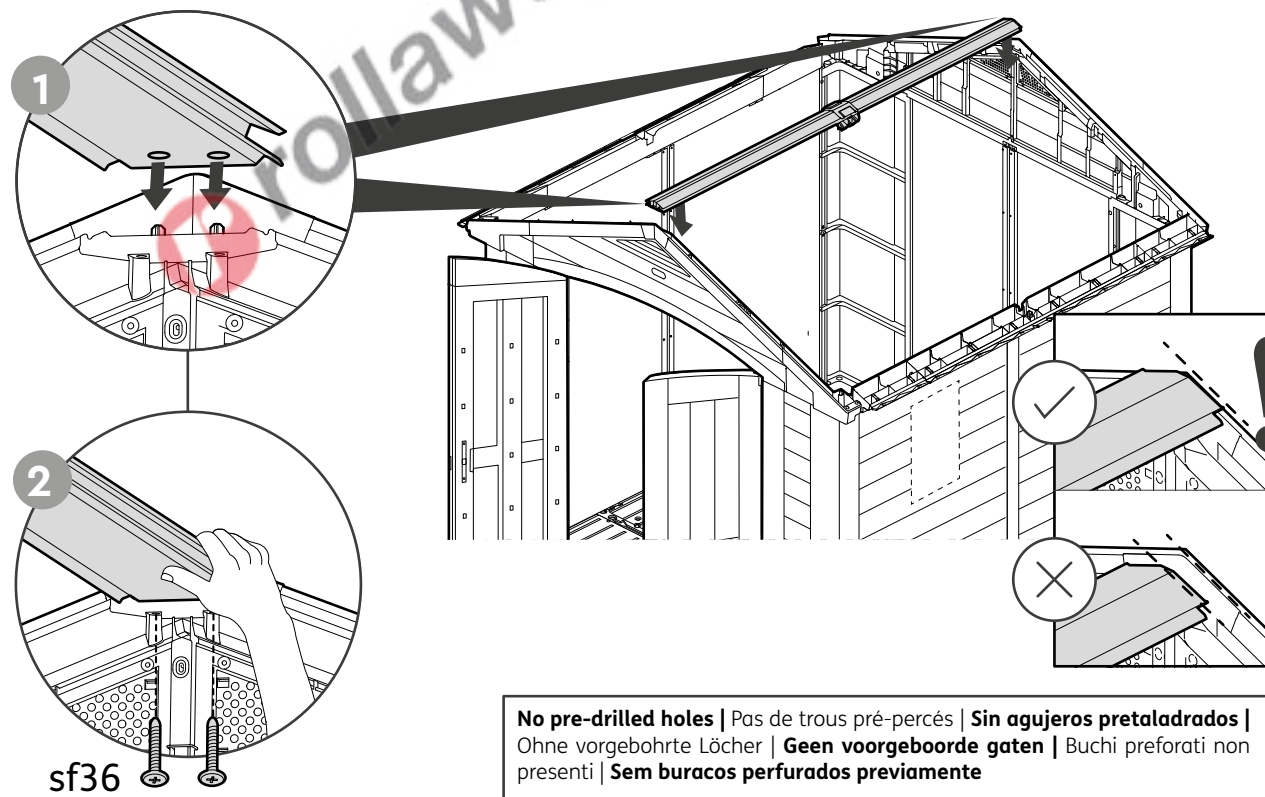
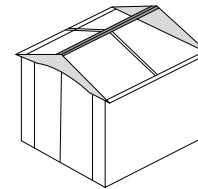

**No pre-drilled holes | Pas de trous pré-perçés | Sin agujeros pretaladrados |**  
 Ohne vorgebohrte Löcher | **Geen voorgeboorde gaten** | Buchi perforati non presenti | **Sem buracos perfurados previamente**



42

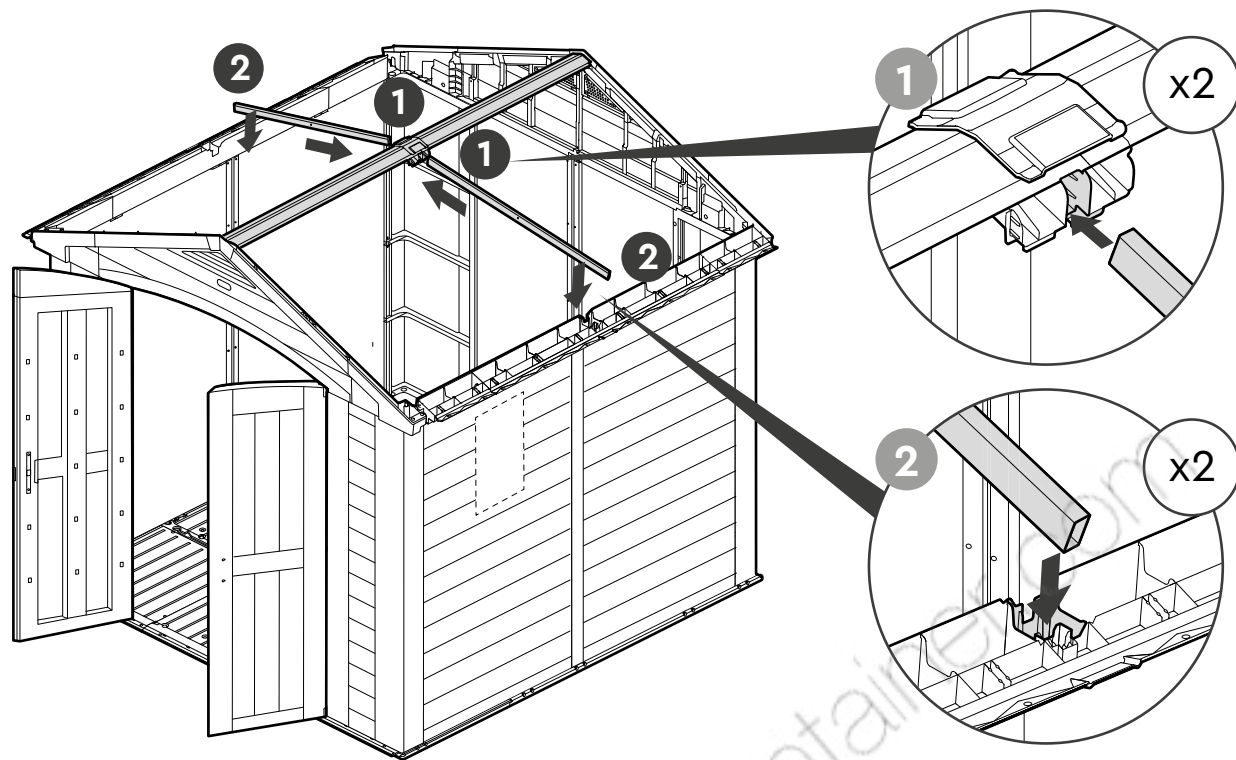
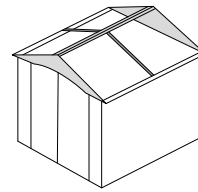
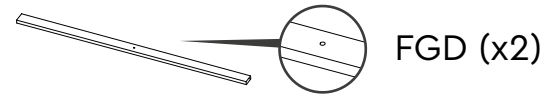

43

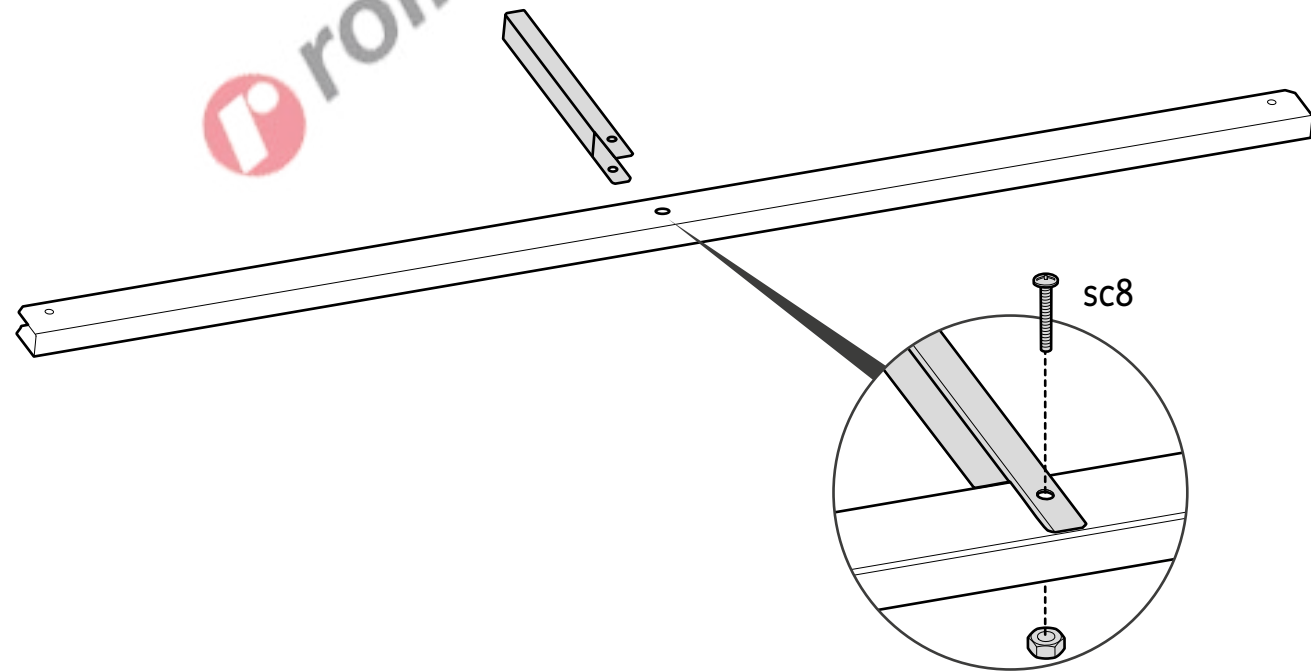
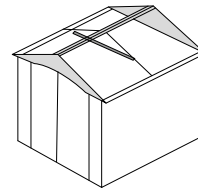

44

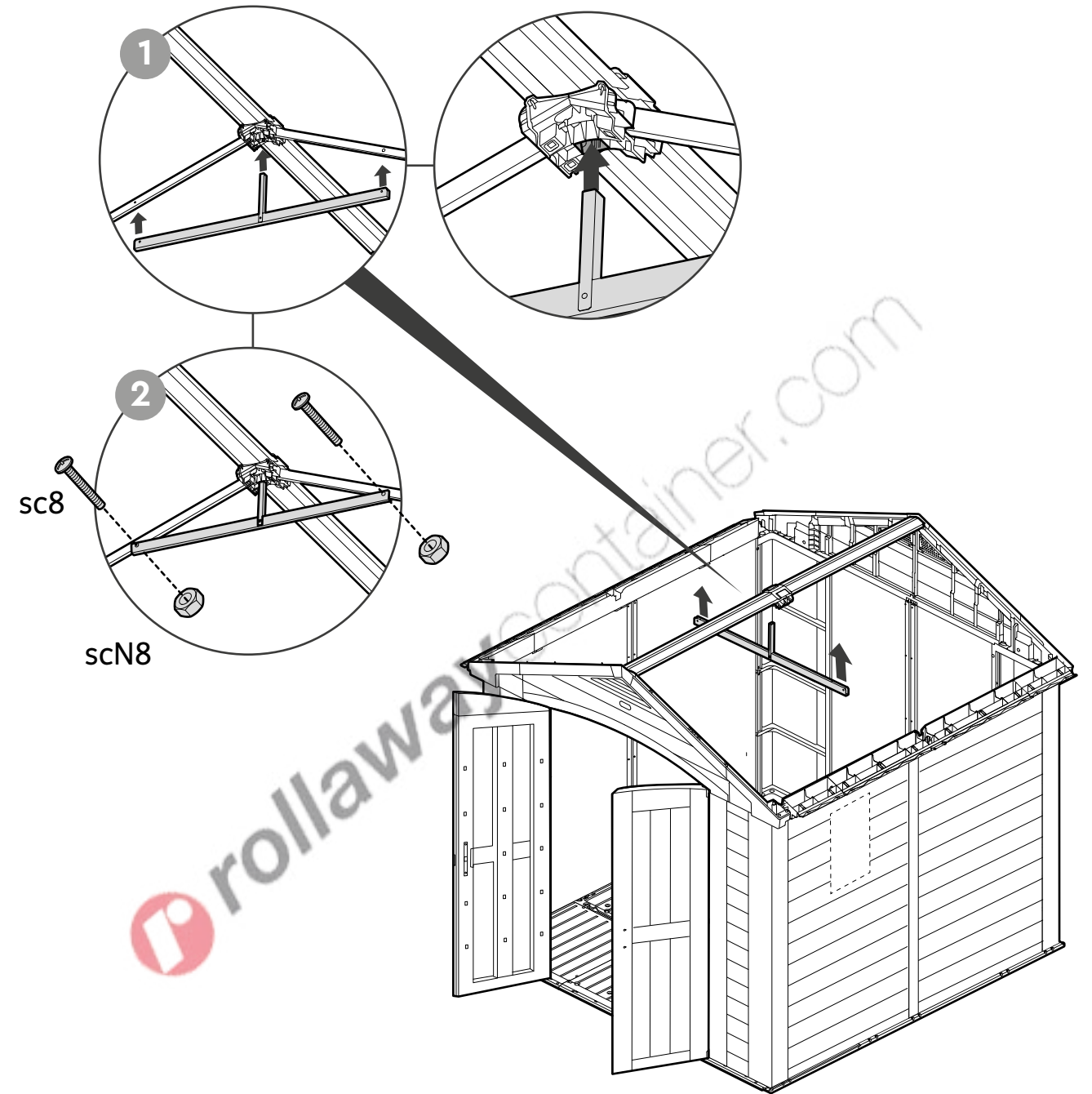
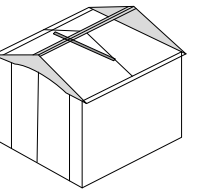
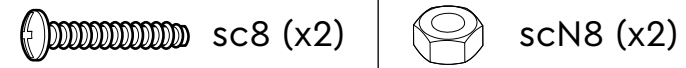



45

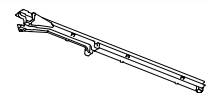

FTC(x2)

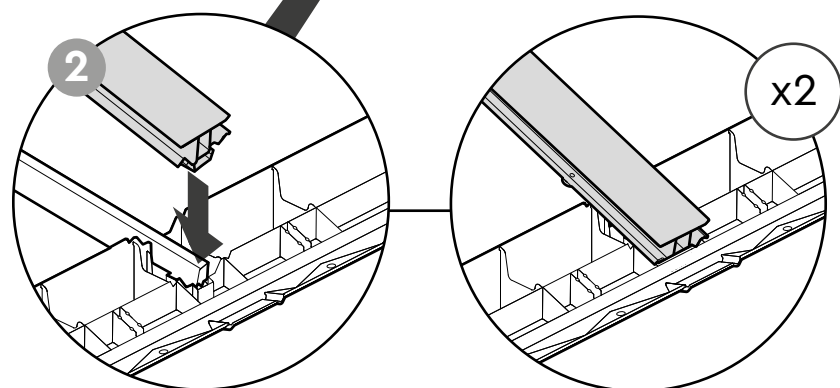
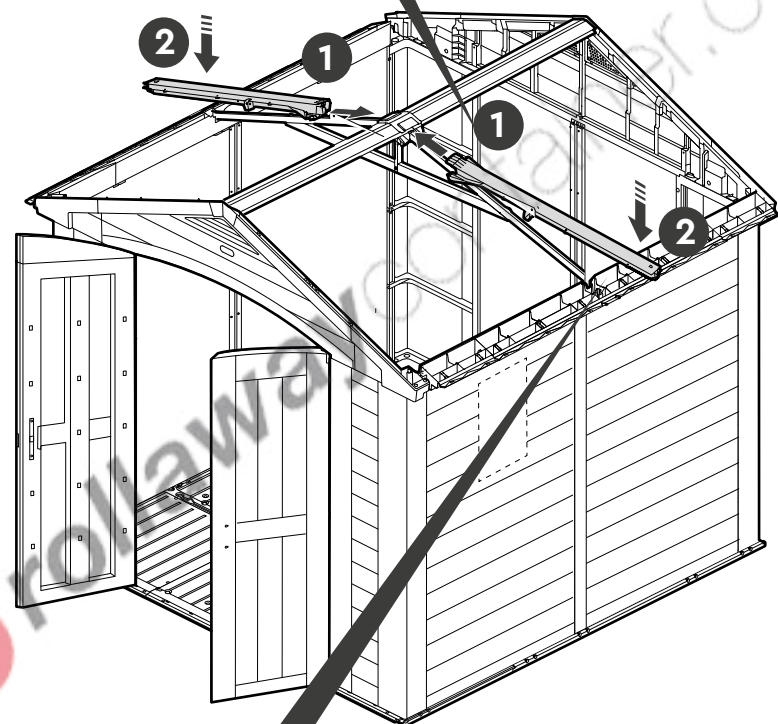
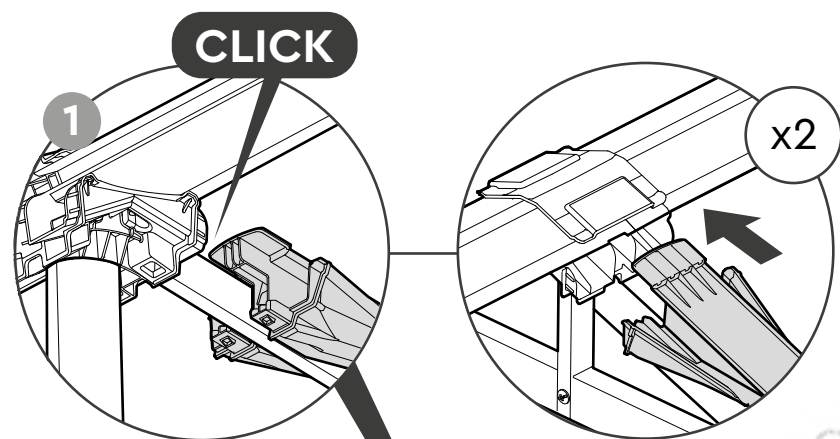
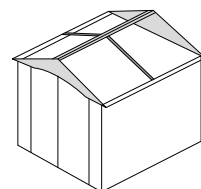

46

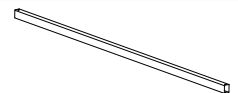

F88 (x4)

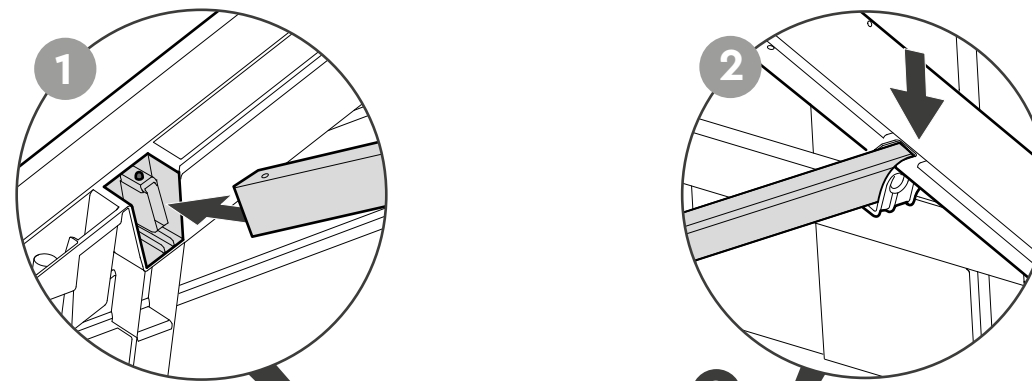
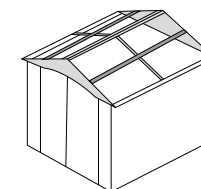

x4

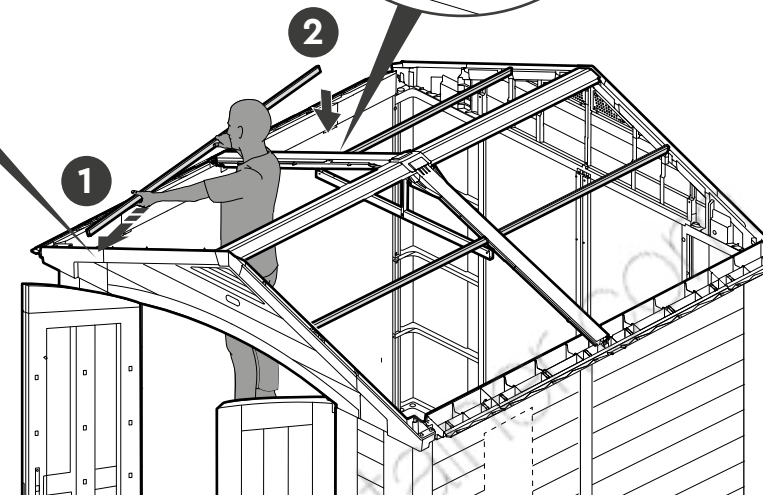

47

sc15 (x4)

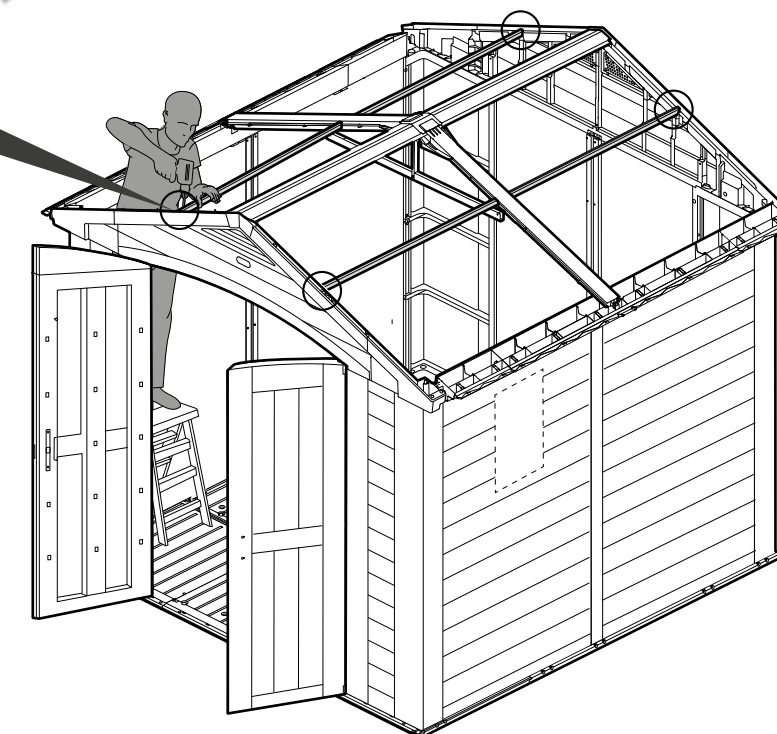
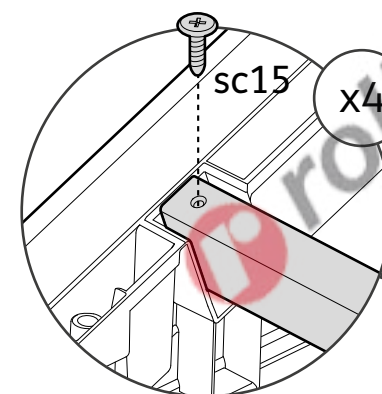
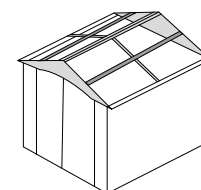

48

sc8 (x4)

scN8 (x4)

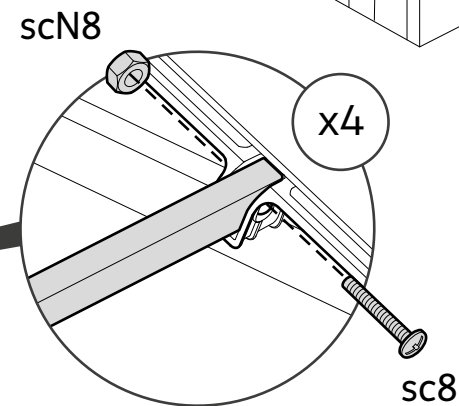
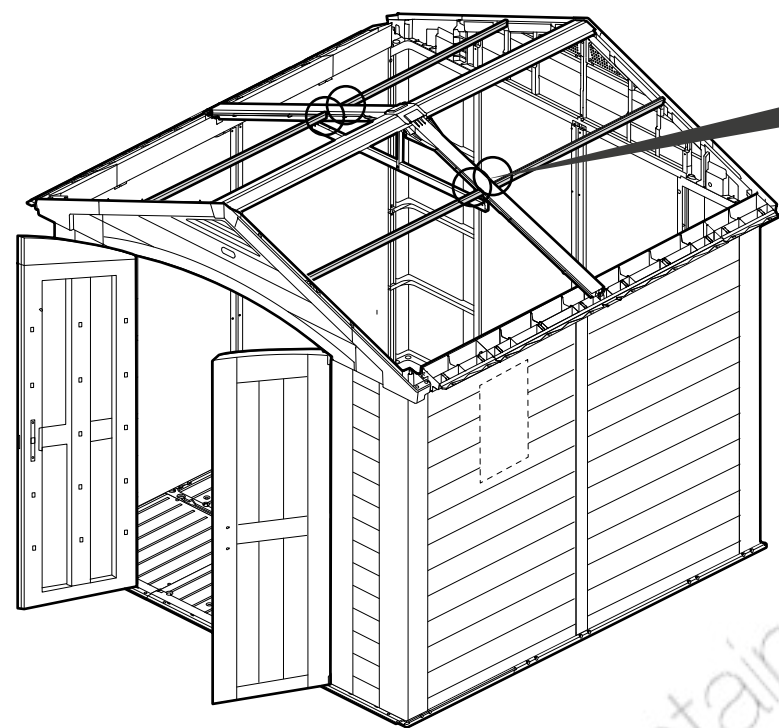
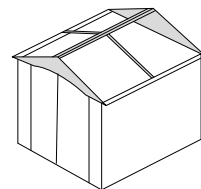

49

s26b (x2)

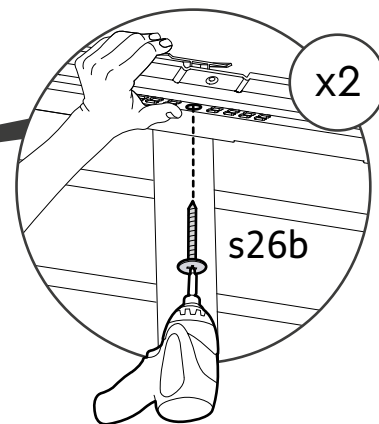
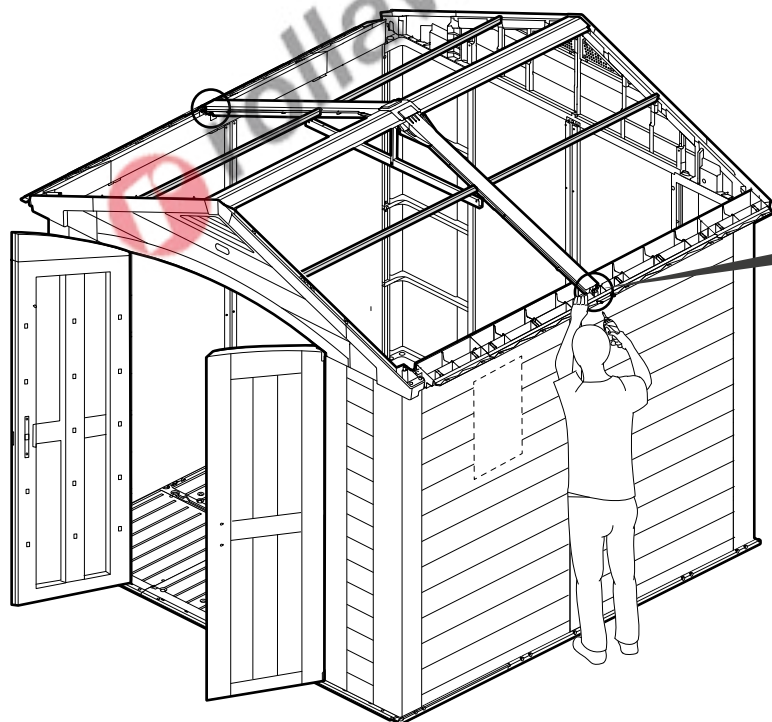
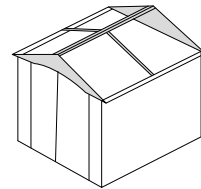

50

T88 (x4)

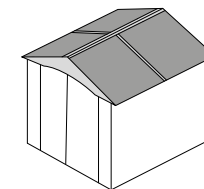

x4

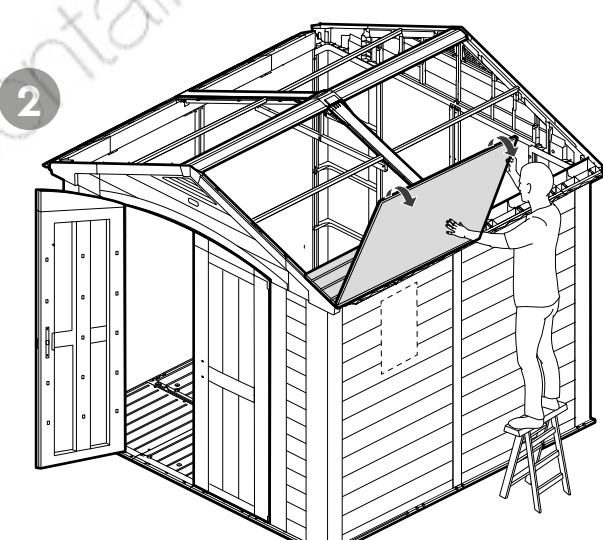
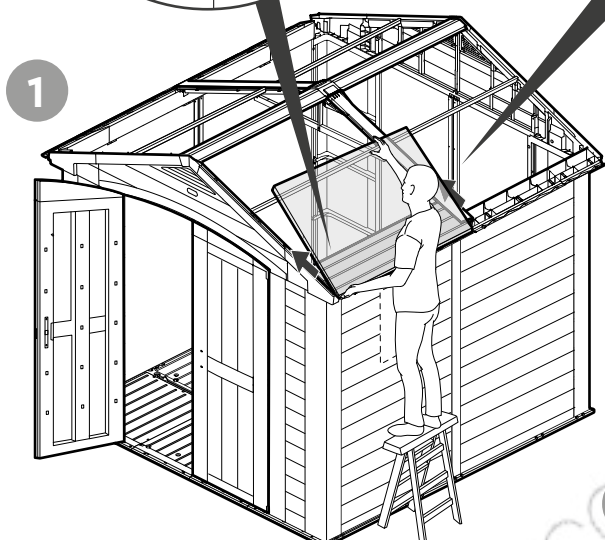
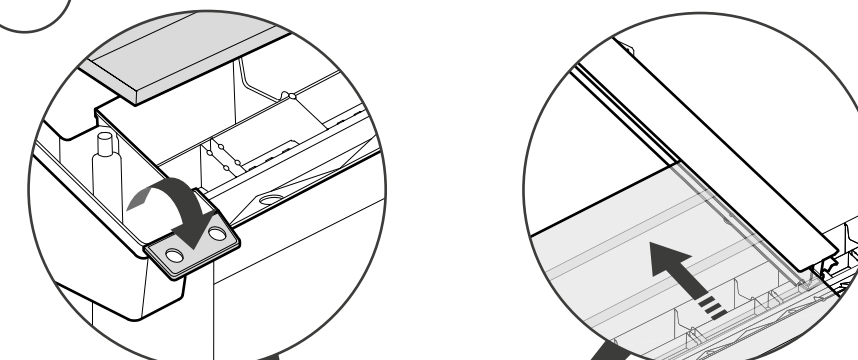

3

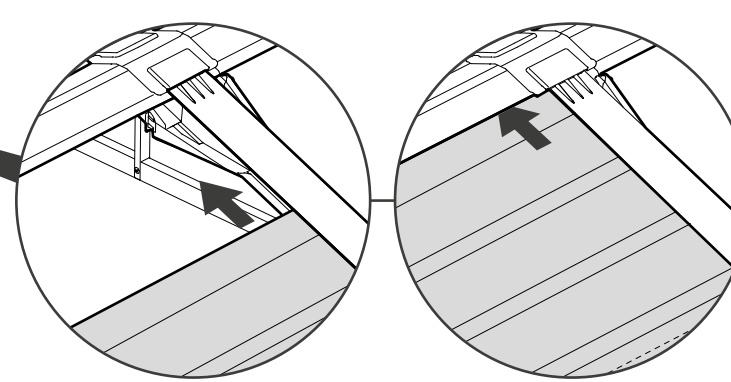
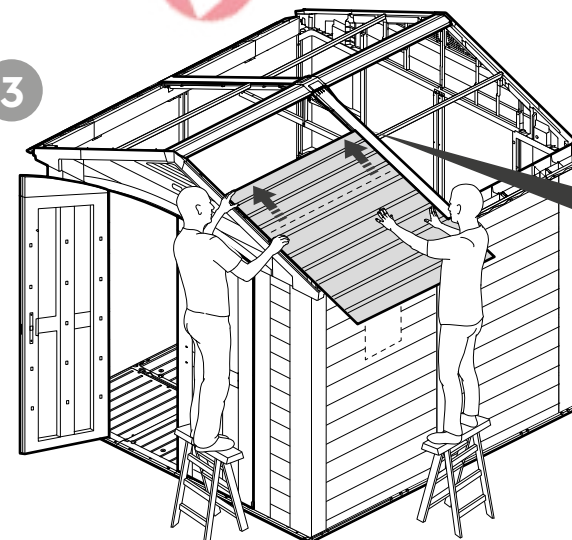



51

TRP (x4)

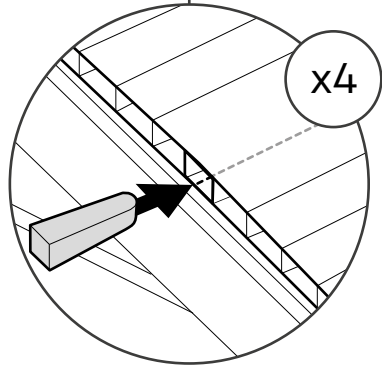
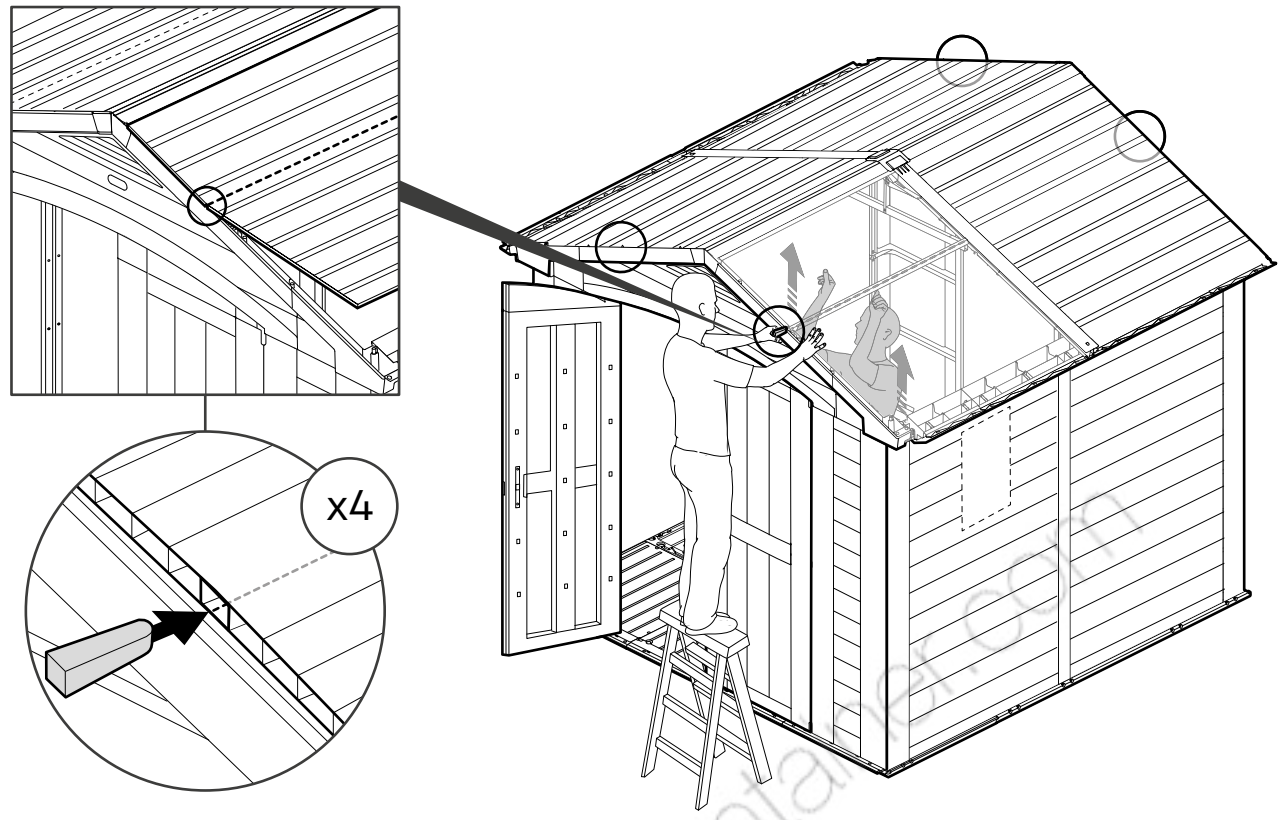
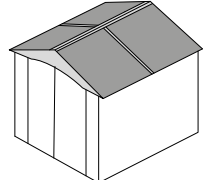

53

sf36 (x20)

SFR (x20)

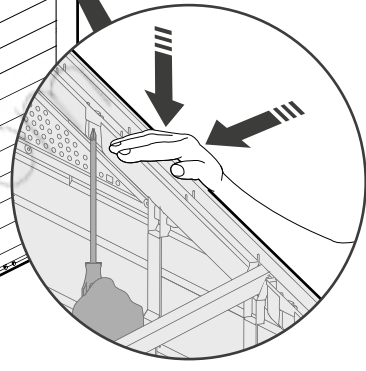
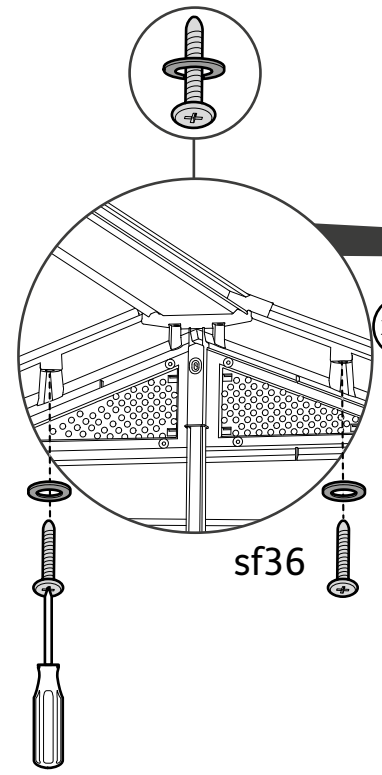
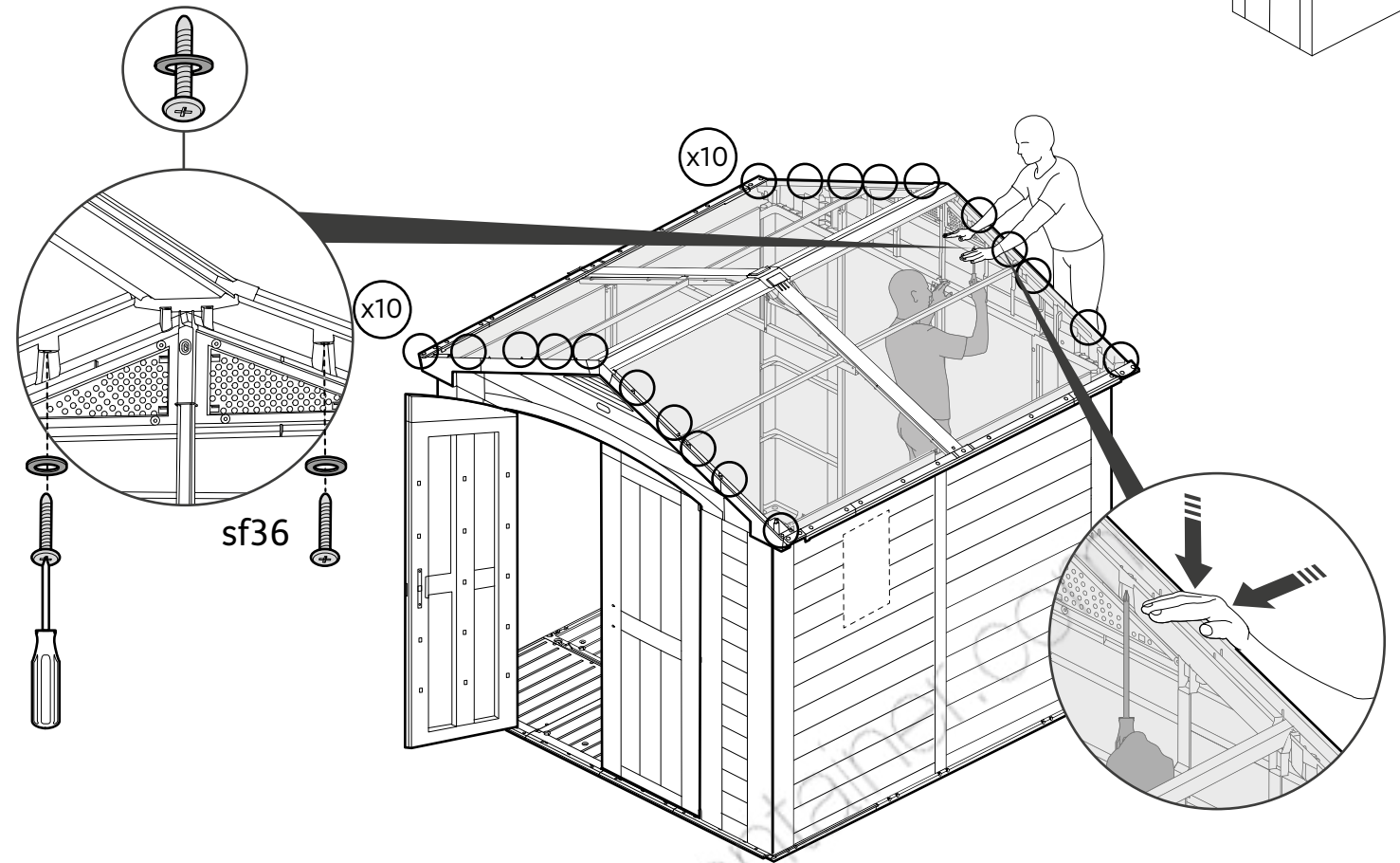
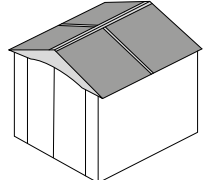

52

sf36 (x30)

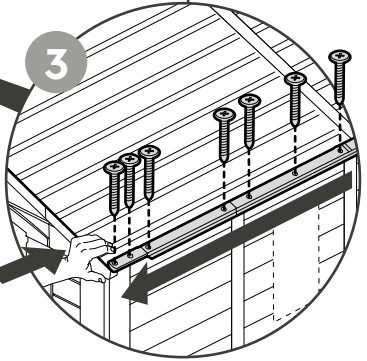
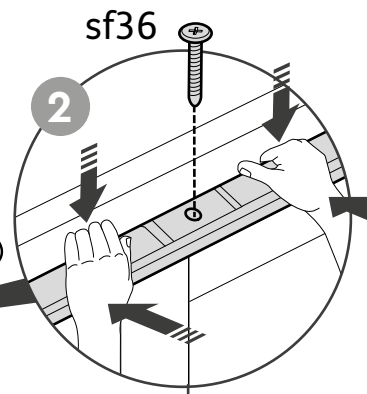
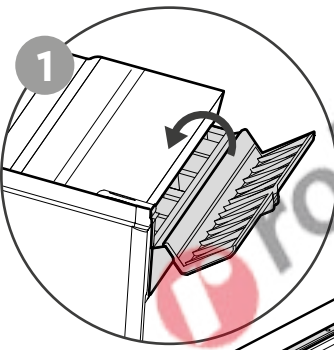
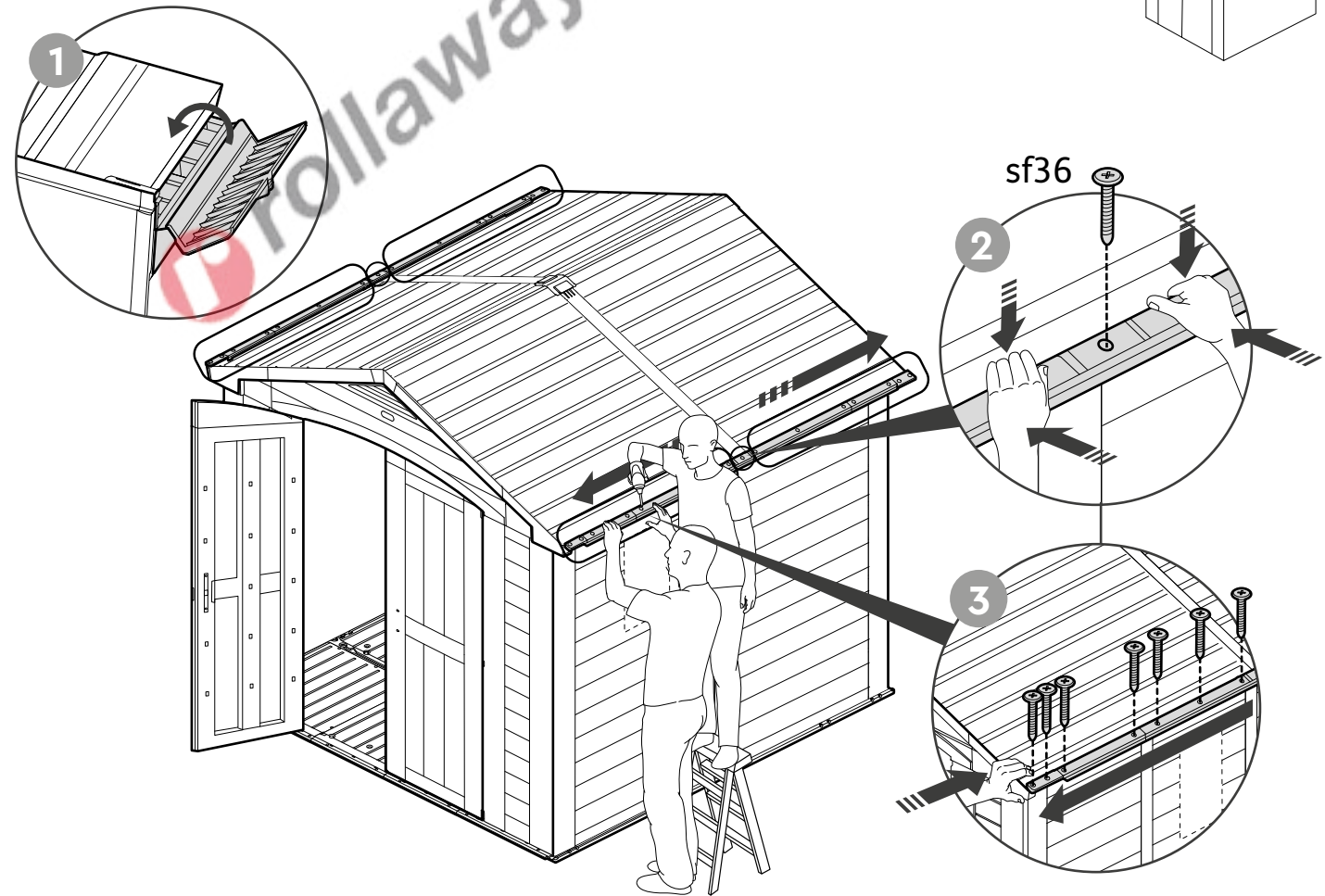
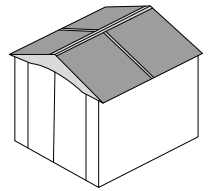

54

sc15 (x12)

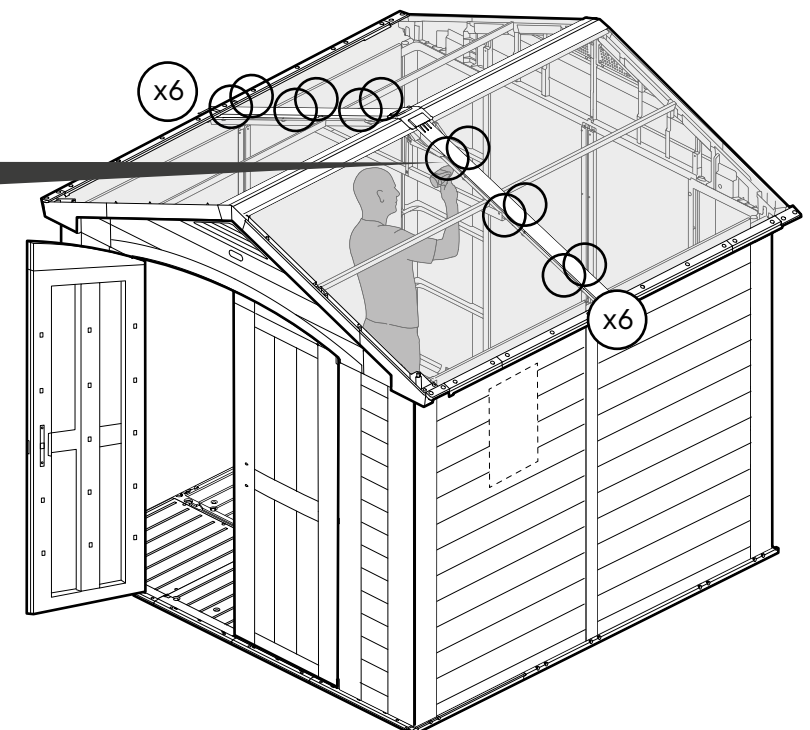
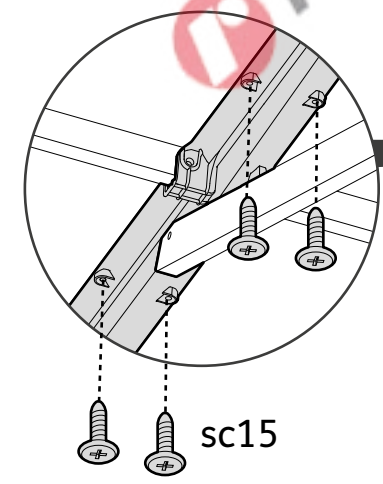
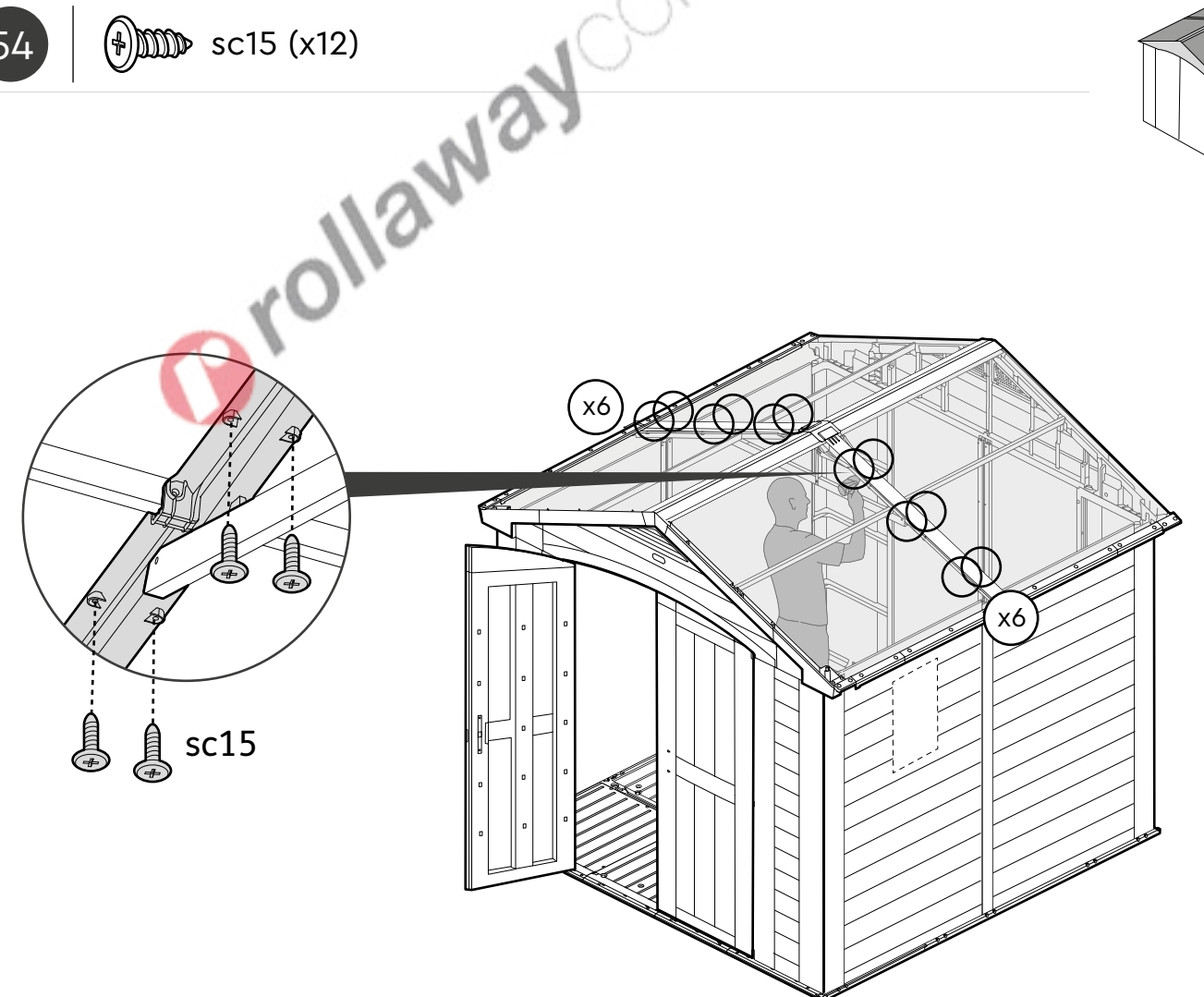
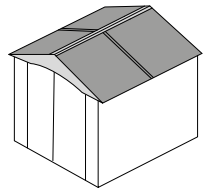



55

IH (x2) | s26b (x4)

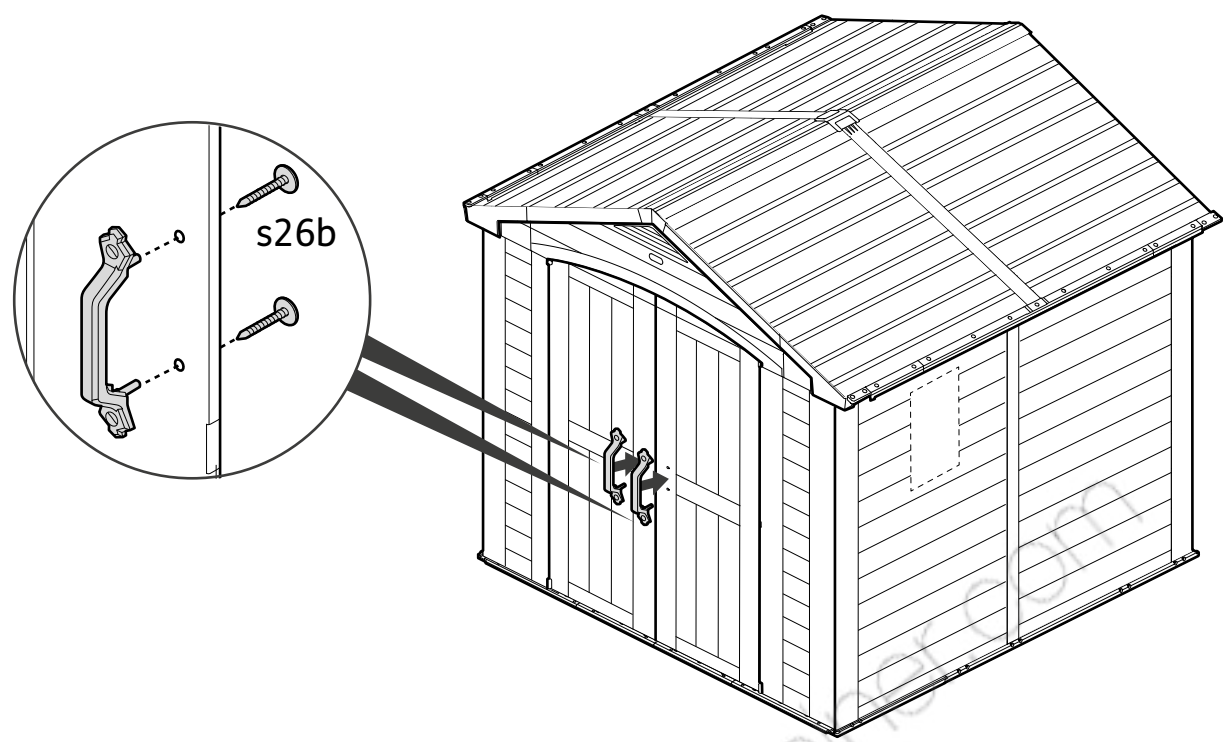

57

FML (x1) | sc5 (x2) | 

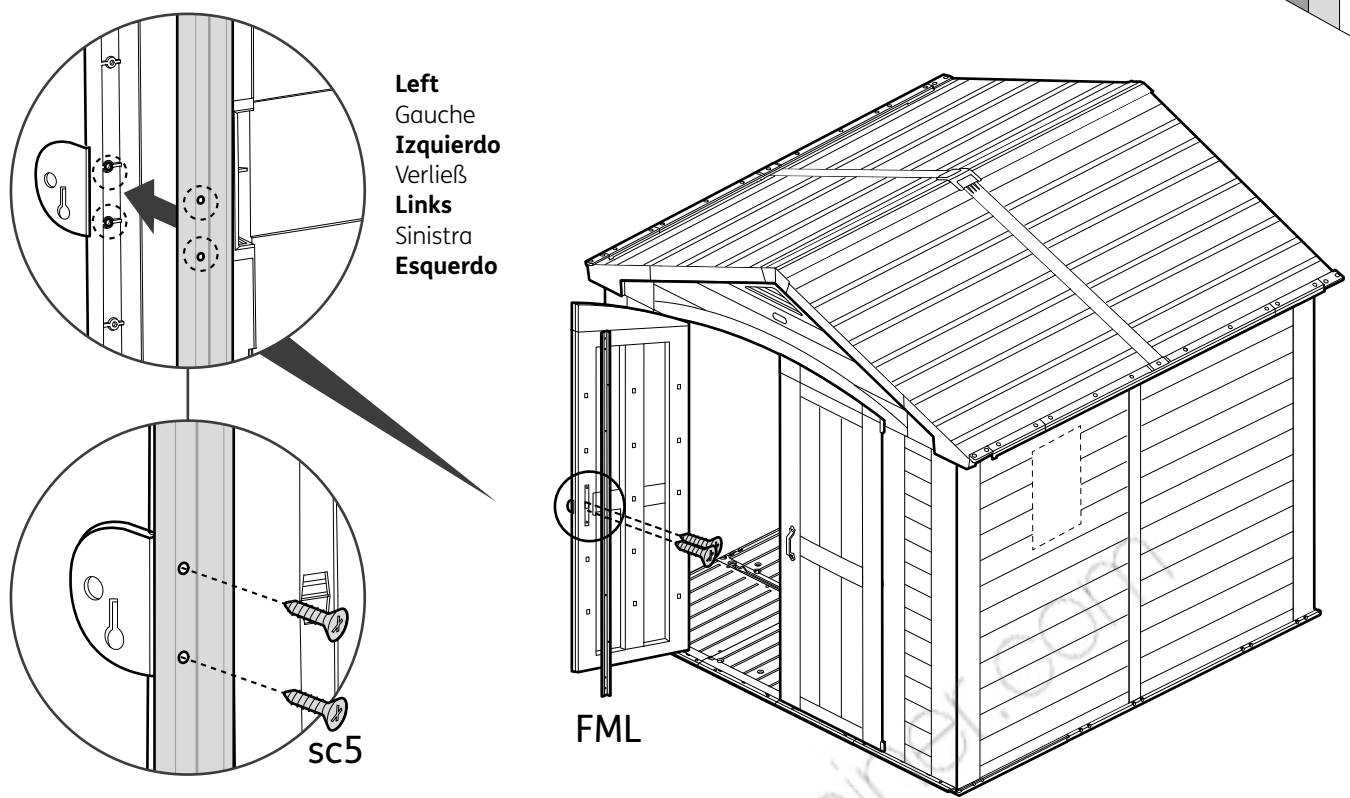

56

DH1 (x1)

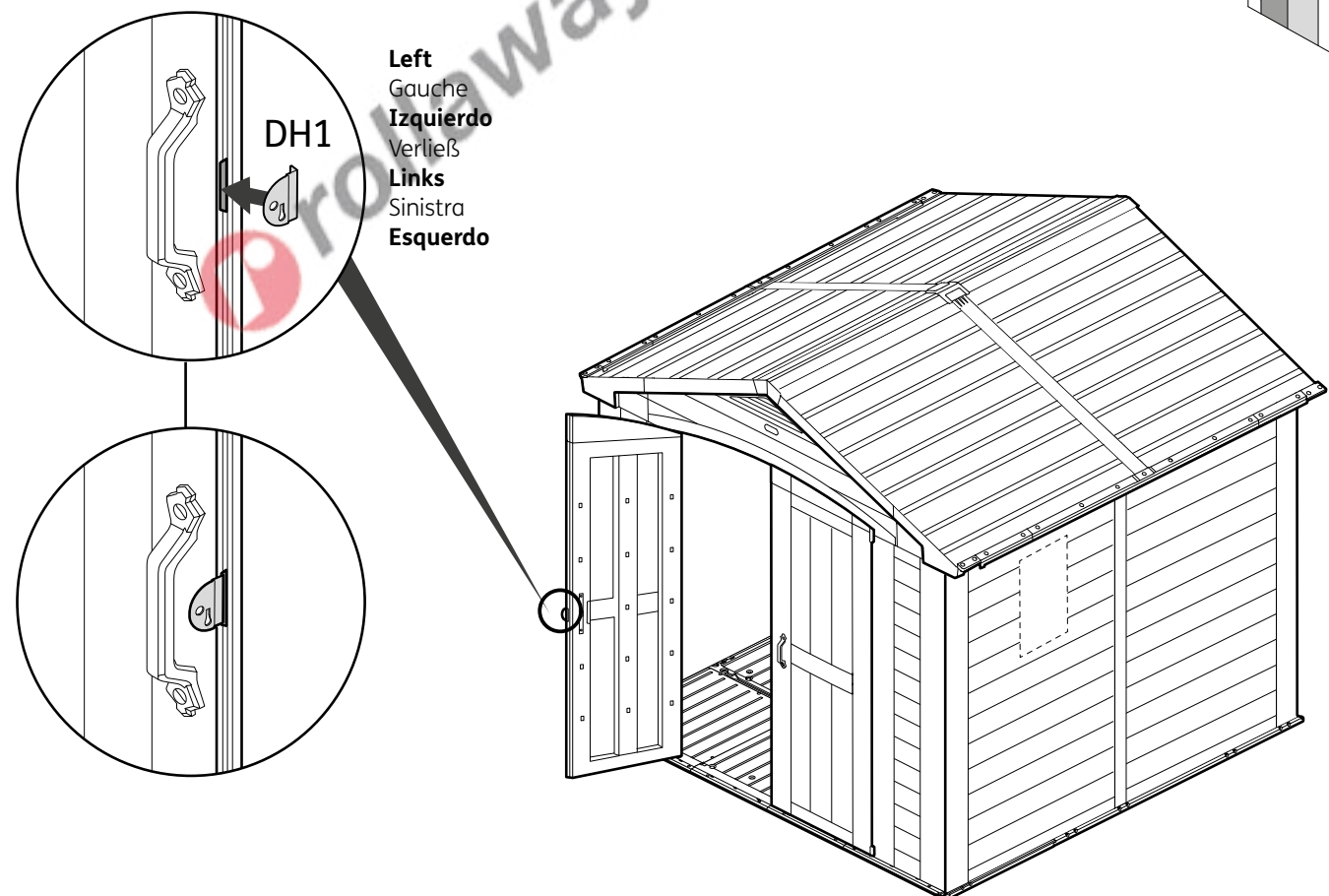

58

FLA (x2) | scw8 (x4)

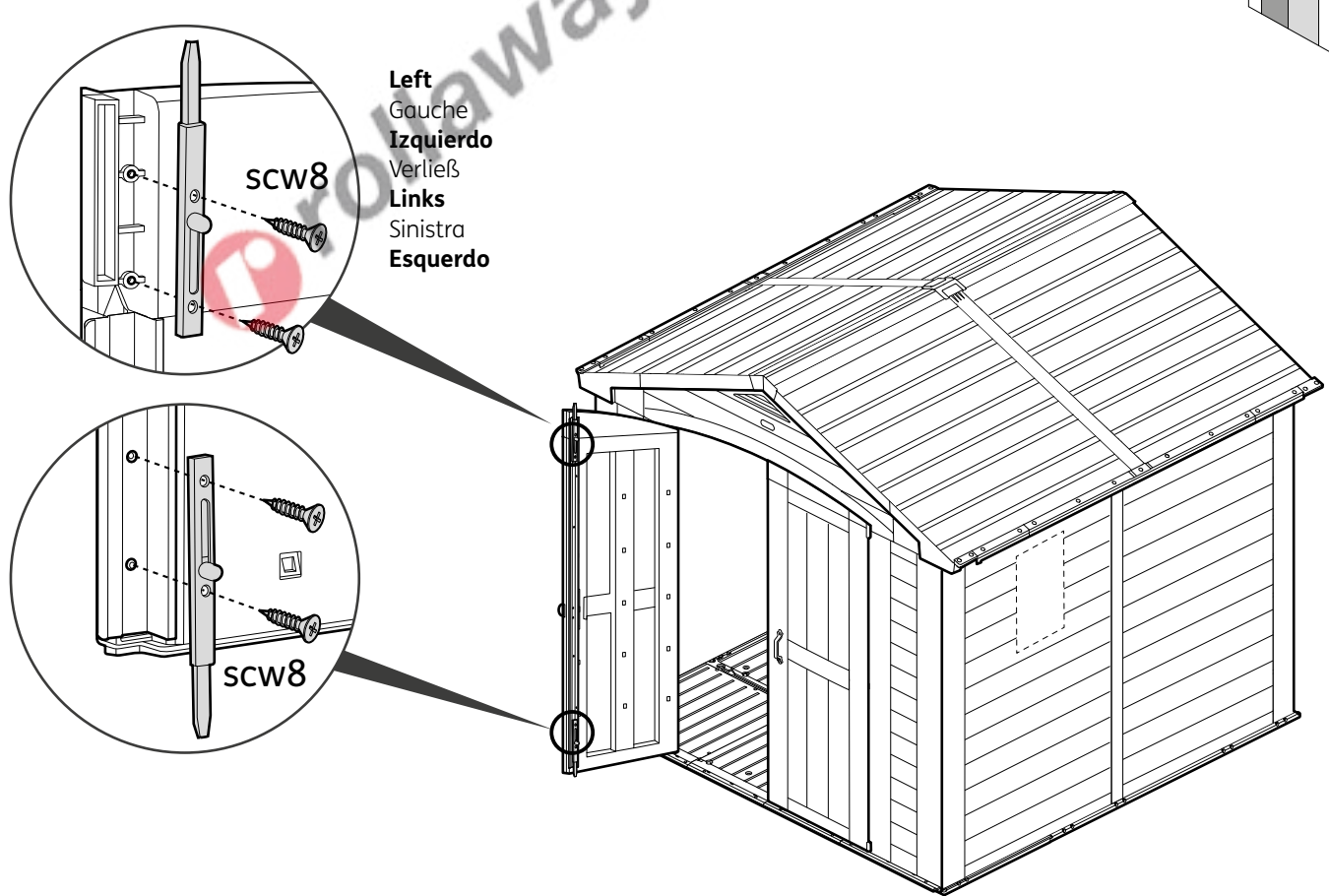

59

sc15 (x7)

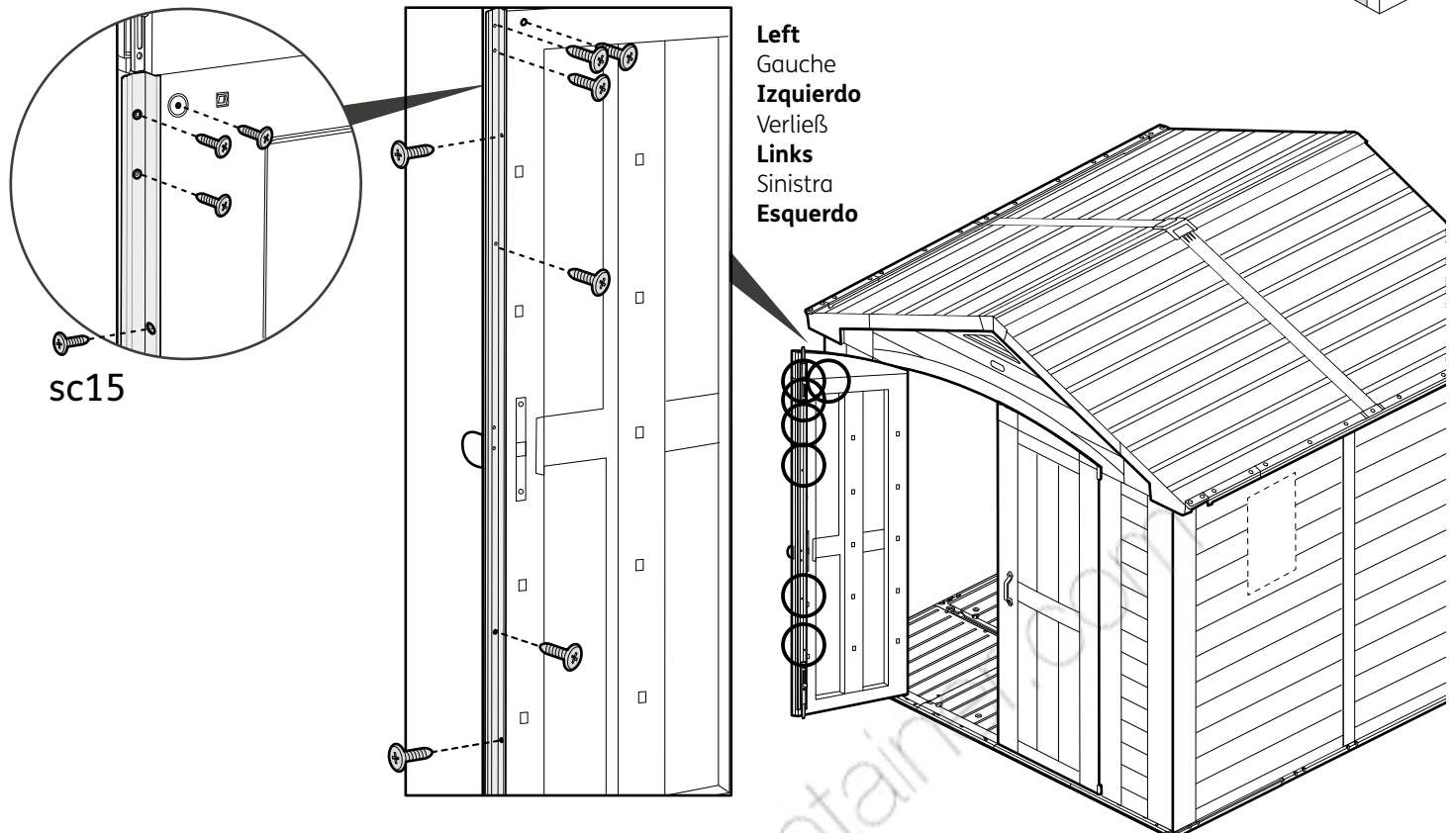
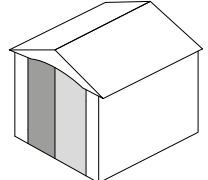

61

FMR (x1) | sc5 (x2)

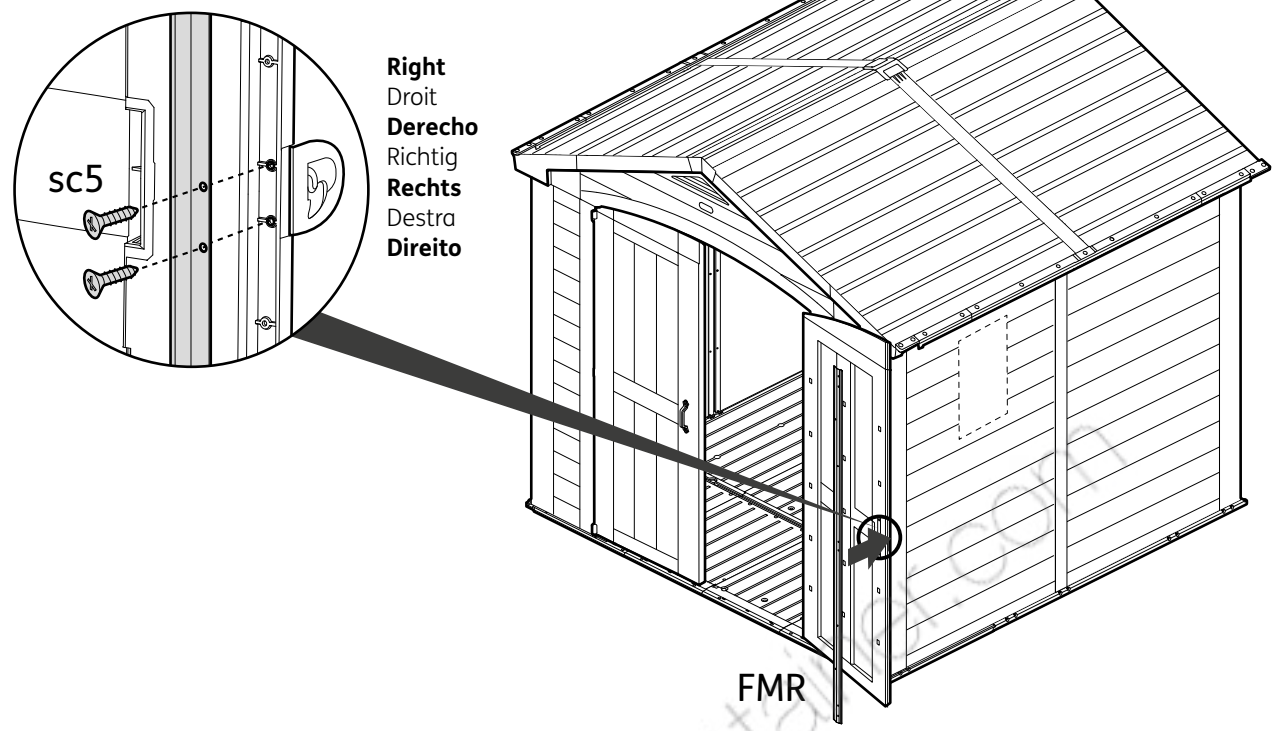
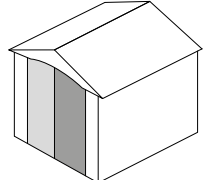

60

DH2 (x1)

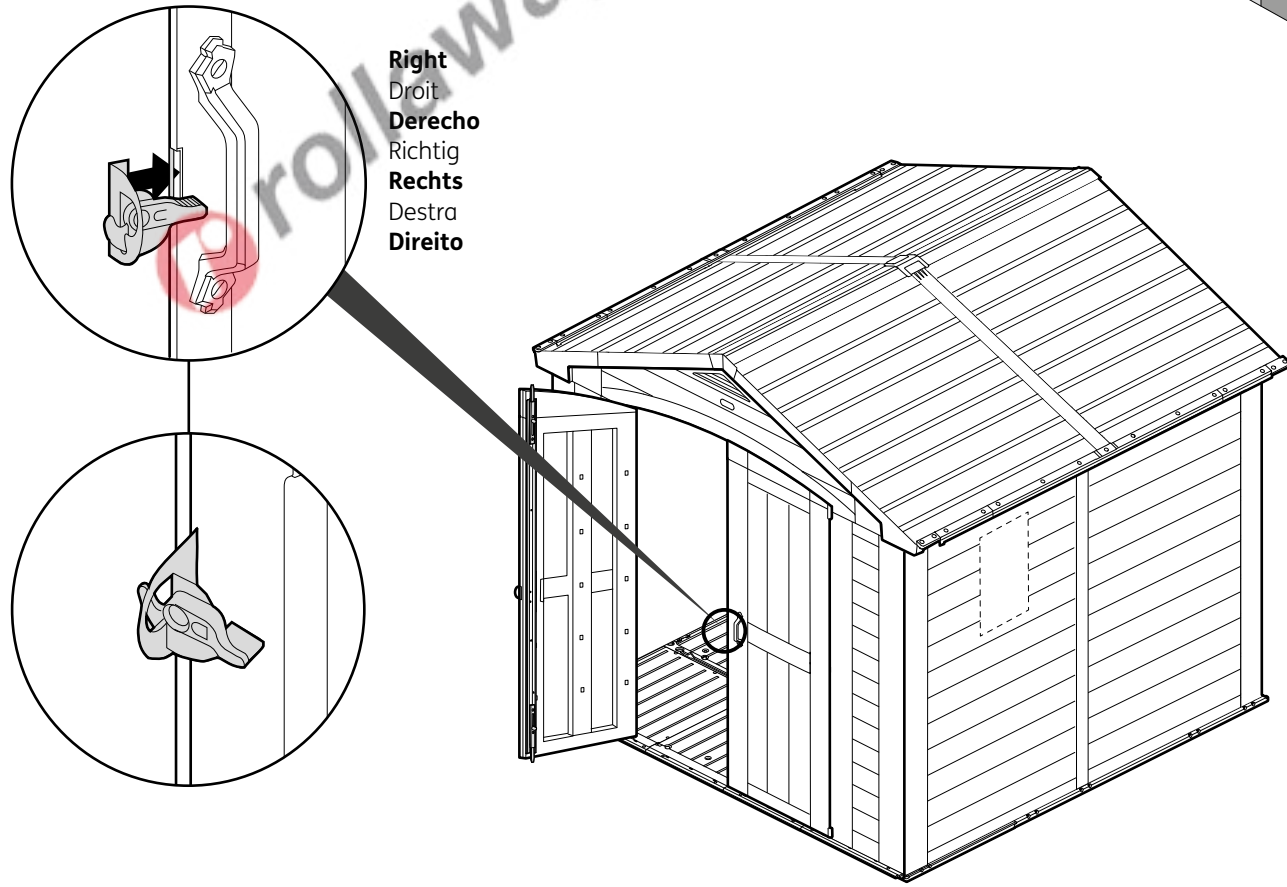
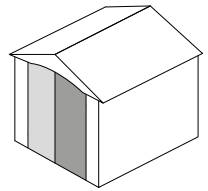

62

sc15 (x7)

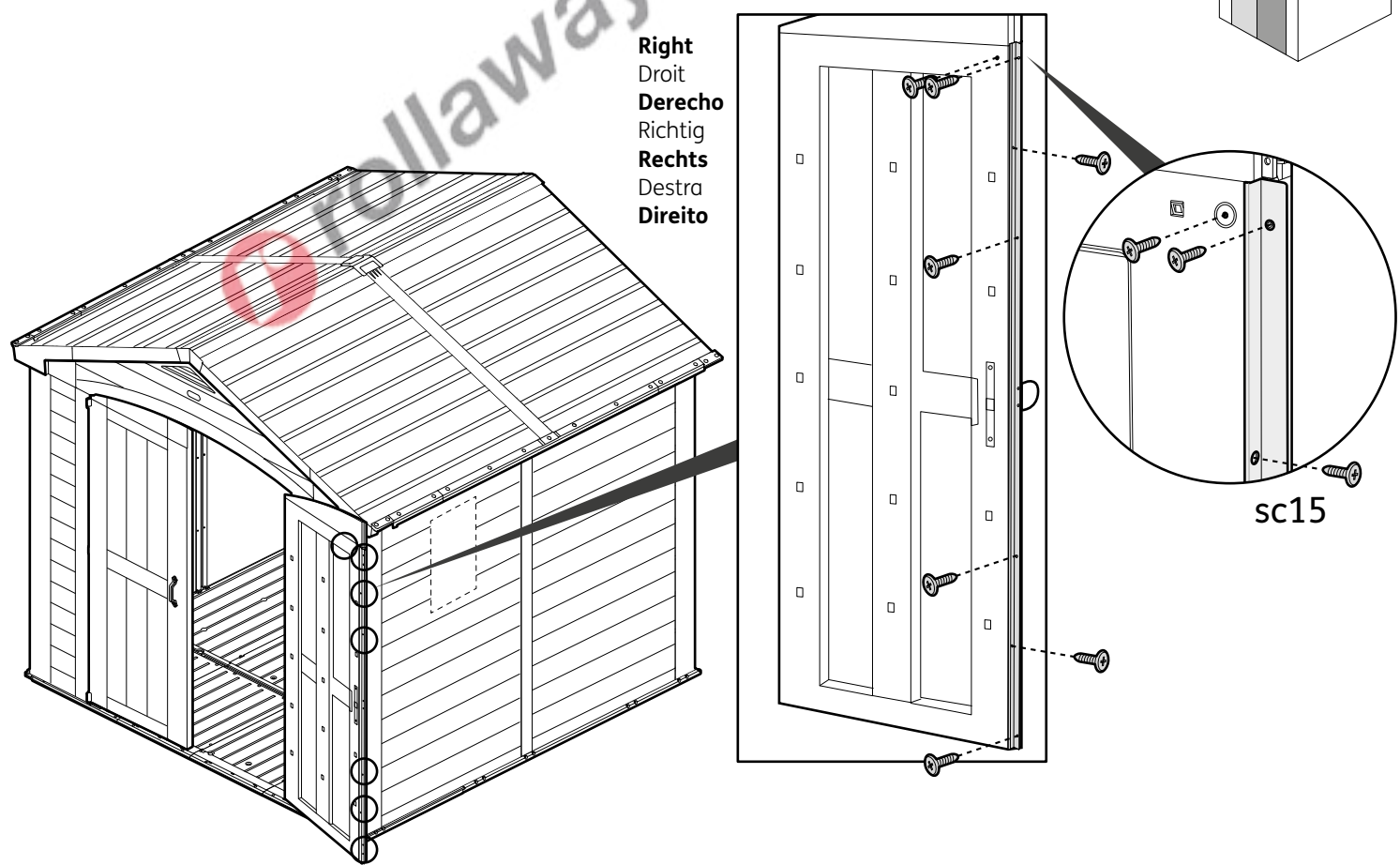
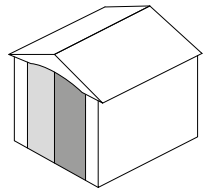



63



FC (x3)

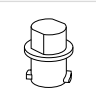

DS (x2)

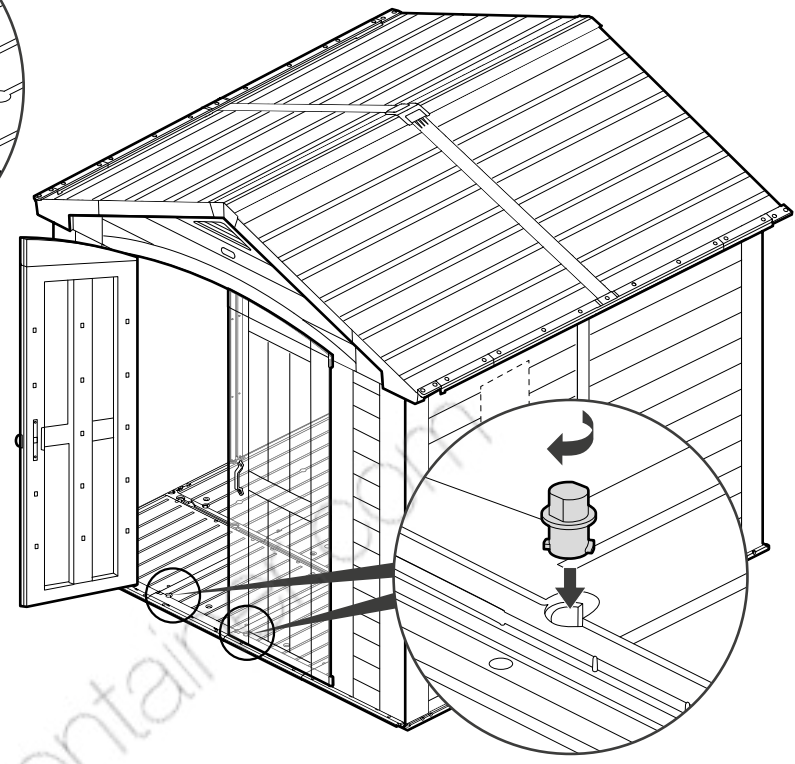
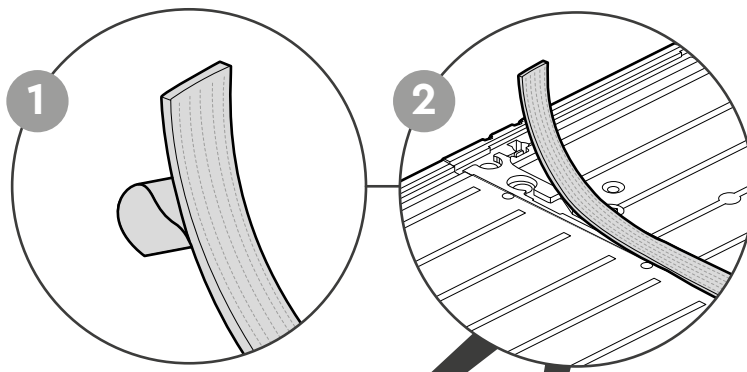
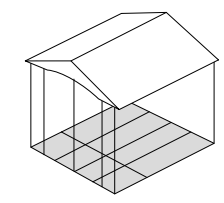
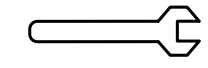

64



sc12 (x4)

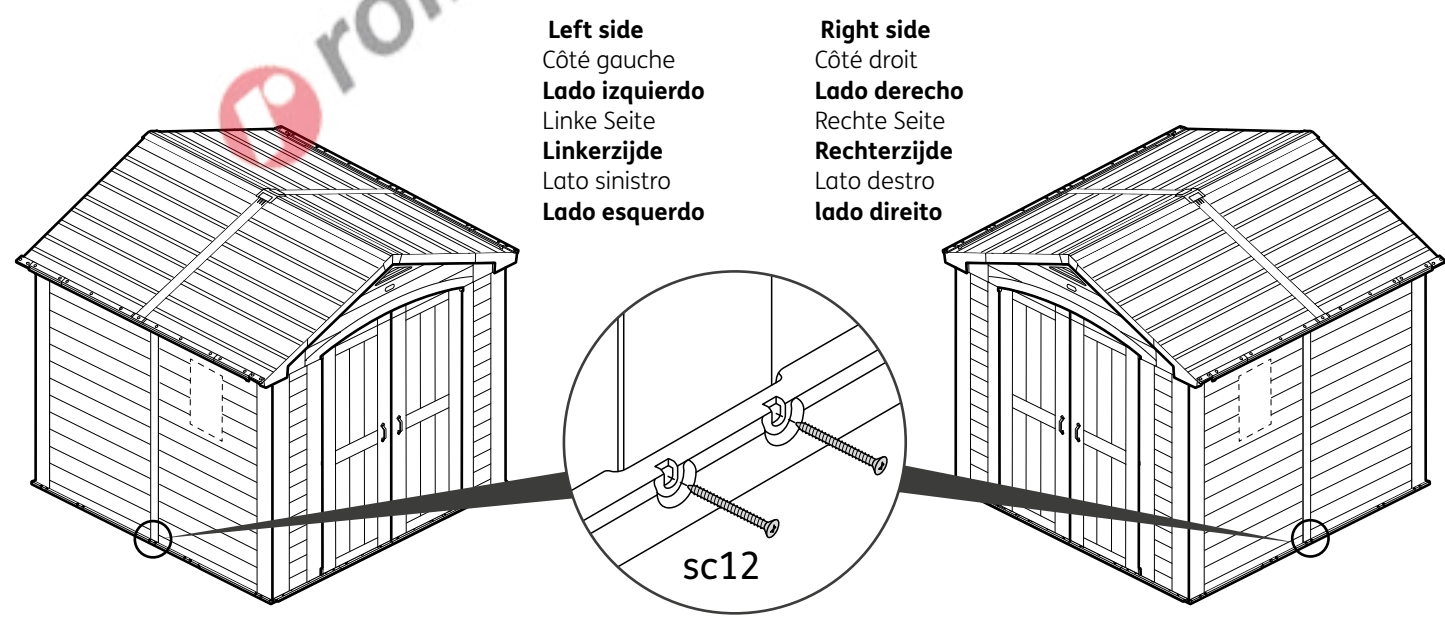
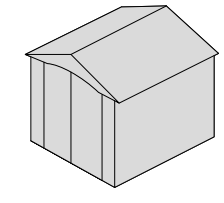

**Left side**  
Côté gauche  
**Lado izquierdo**  
Linke Seite  
**Linkerzijde**  
Lato sinistro  
**Lado esquerdo**

**Right side**  
Côté droit  
**Lado derecho**  
Rechte Seite  
**Rechterzijde**  
Lato destro  
**lado direito**

**WINDOW ASSEMBLY | MONTAGE DE LA FENÊTRE | VENTANA DEL TECHO | FENSTERHMONTAG | ERAAMMONTAGE | ASSEMBLAGGIO DELLA FINESTRA | MONTAGEM DO JANELA**

65



FWO (x1)

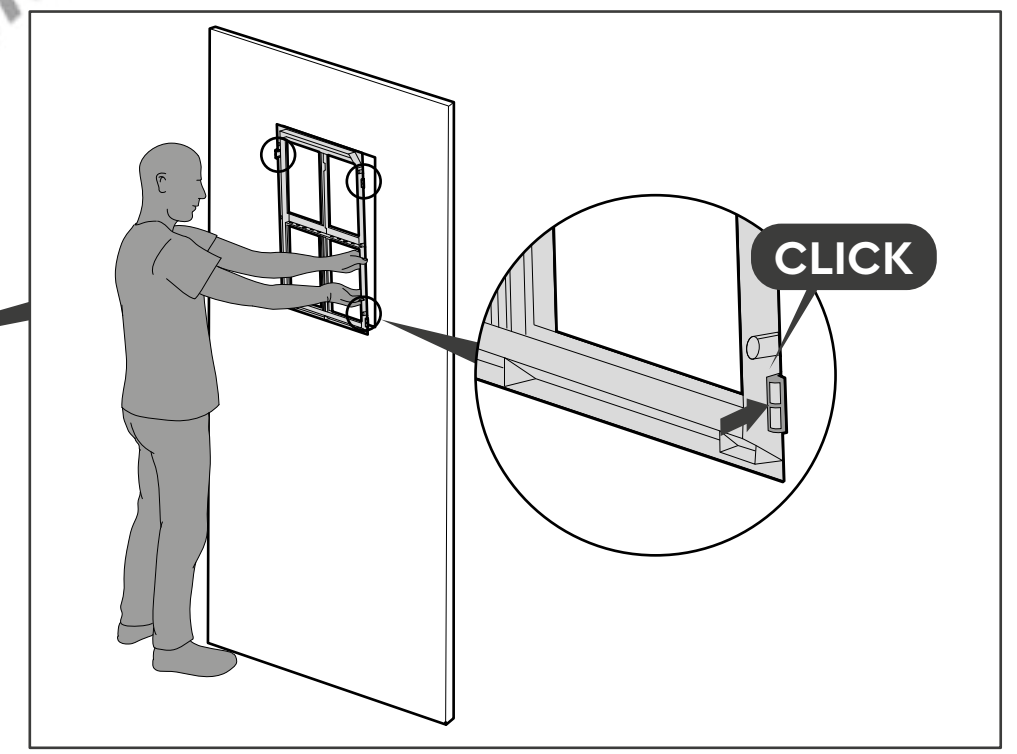
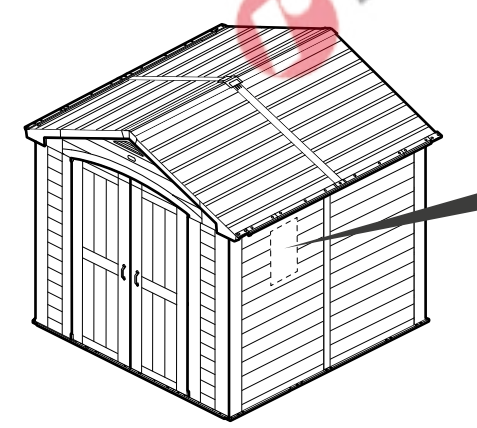
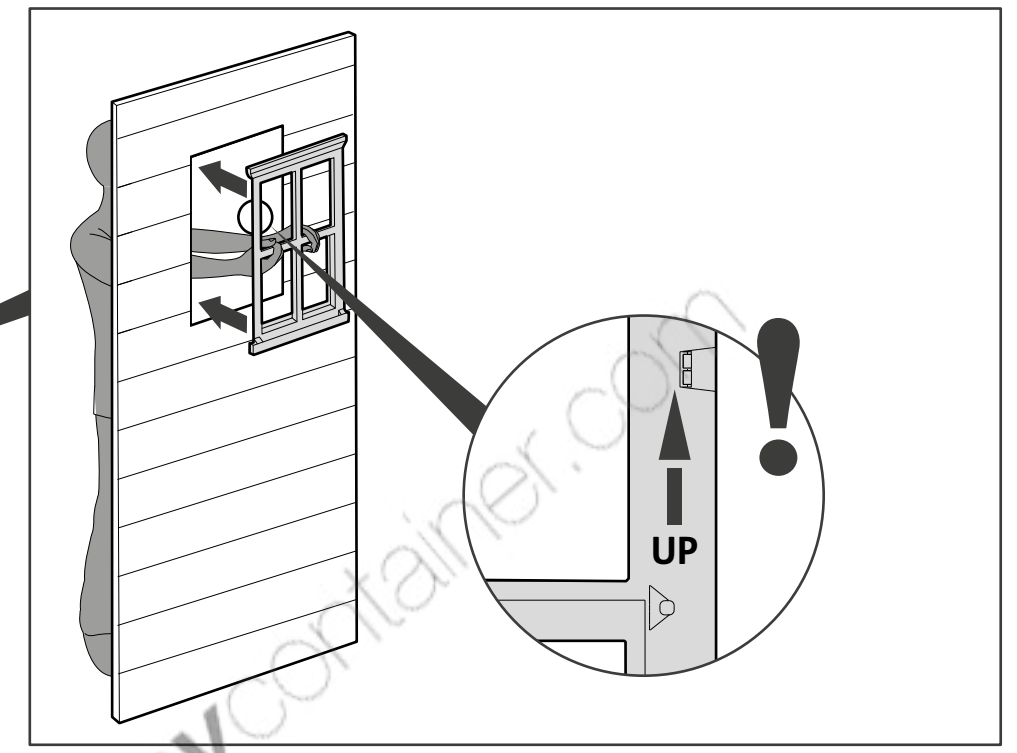
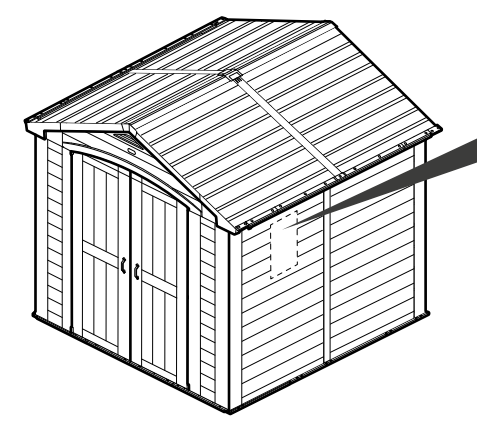
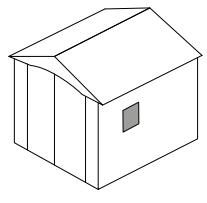



66

FWT (x1)

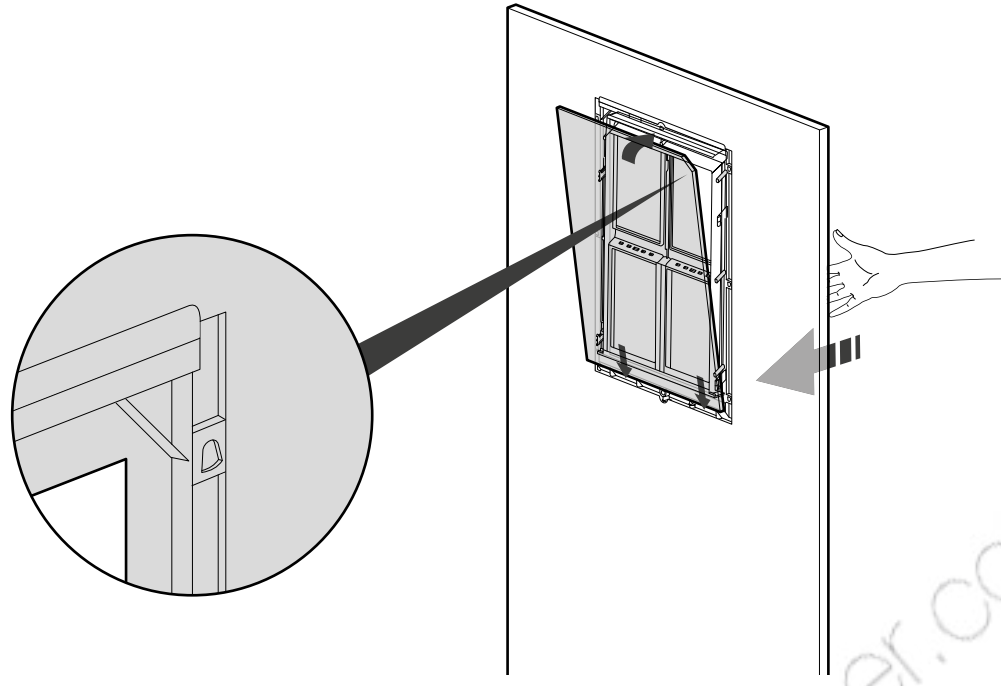
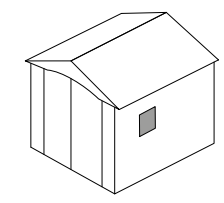
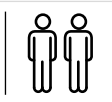

67

YWI (x1)

sc15 (x8)

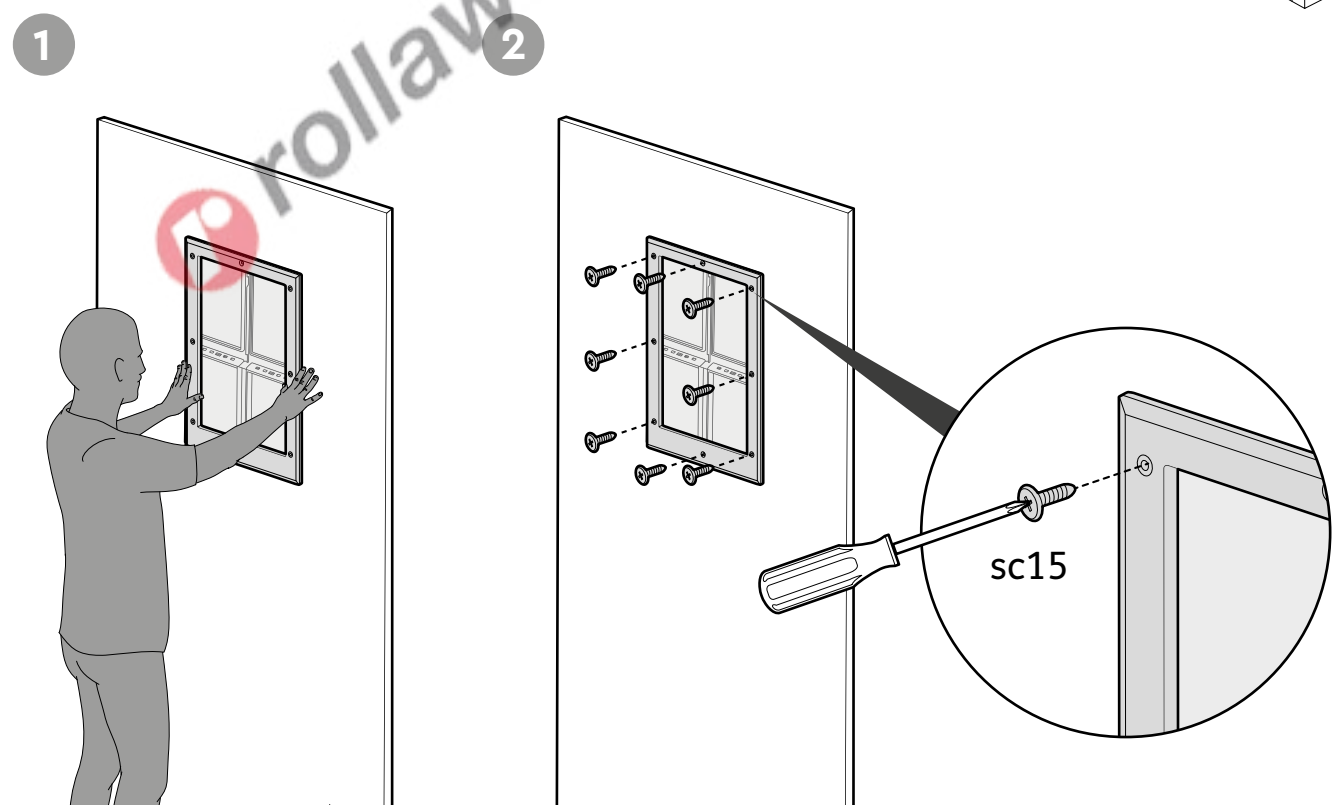
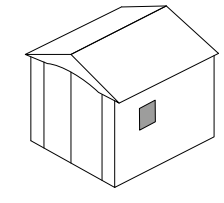

68

sc15 (x12)

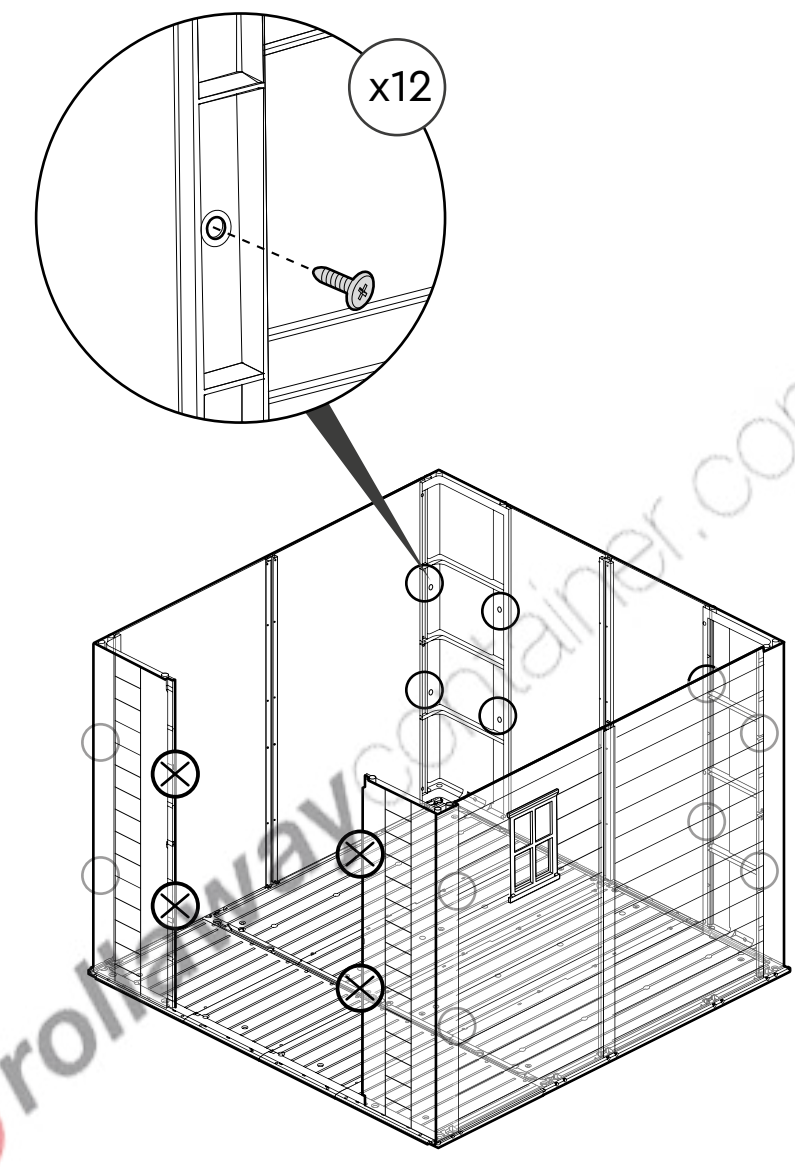
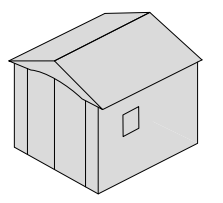
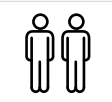

**A** OPTION | OPCIÓN | OPTIE | OPZION | OPZIONE | OPÇÃOE

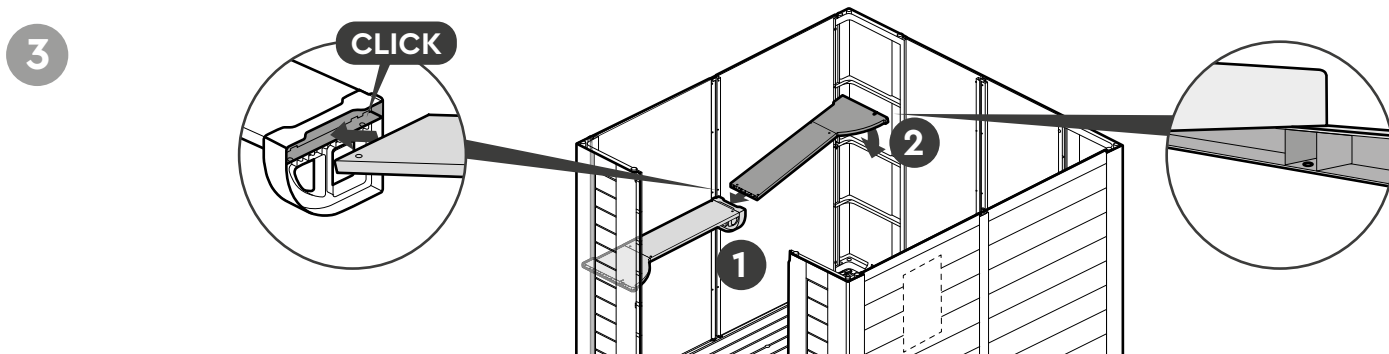
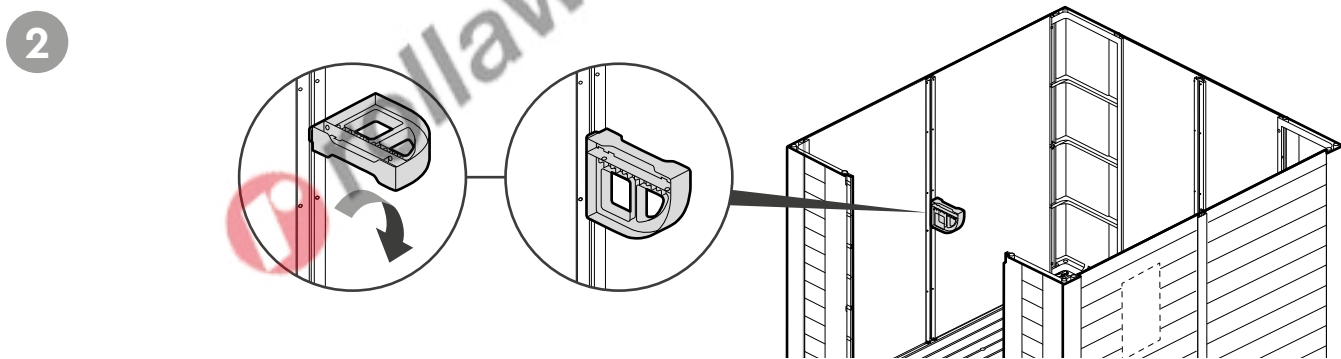
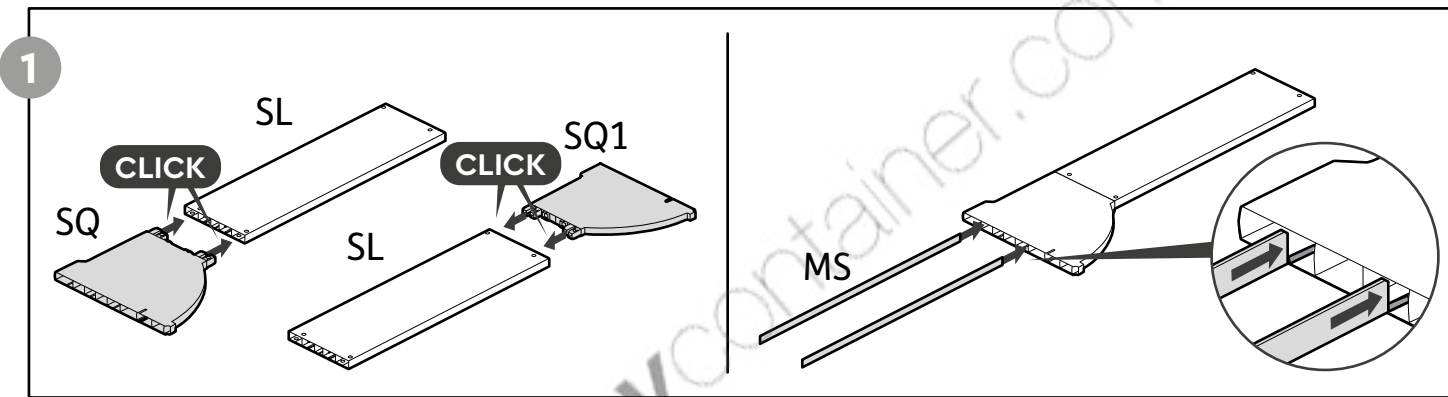
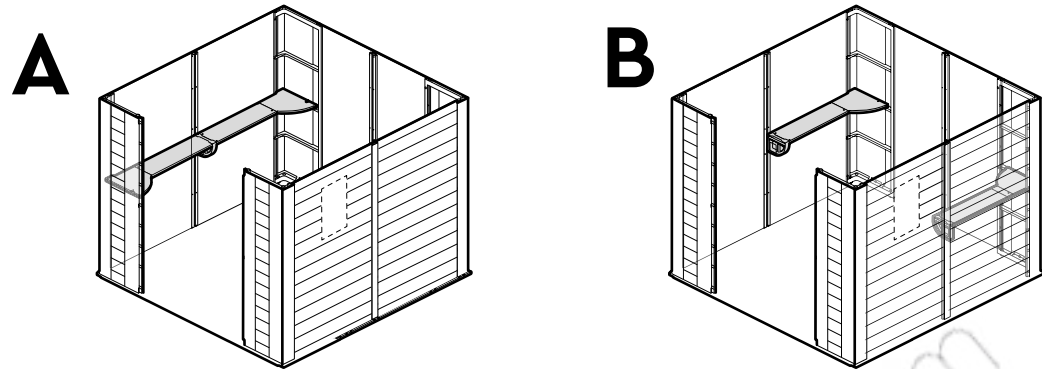
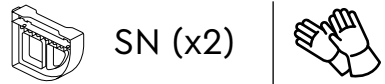

**B** OPTION | OPCIÓN | OPTIE | OPZION | OPZIONE | OPÇÃOE

**SECURING THE SHED TO A FOUNDATION**

Affix the shed to the foundation by drilling holes in the shed floor at the pre-marked locations and screwing it into the foundation using appropriate screws (screws not included).

**FIXER L'ABRI SUR UNE FONDATION**

Fixez l'abri à la fondation en perçant des trous dans le sol aux endroits pré-marqués et en insérant des vis adéquates dans la fondation (vis non fournies).

**ASEGURAR EL COBERTIZO A UN CIMIENTO**

Fije el cobertizo a los cimientos perforando agujeros en el suelo del cobertizo en los lugares previamente marcados y atornillelo a los cimientos utilizando los tornillos adecuados (los tornillos no están incluidos).

**ABSICHERN DES SCHUPPENS AN EIN FUNDAMENT**

Bringen Sie den Schuppen auf dem Fundament an, indem Sie an den Markierungen Löcher in den Schuppenboden bohren und diesen mit passenden Schrauben auf dem Fundament festschrauben (Schrauben nicht enthalten).

**HET SCHUURTJE OP HET UNDAMENT VASTZETTEN**

Bevestig het schuurtje aan de fundering door op de aangegeven plaatsen gaten te boren in de vloer van het schuurtje en het schuurtje aan de fundering te schroeven met behulp van passende schroeven (schroeven niet inbegrepen).

**ASSICURARE LA CASETTA ALLE FONDAMENTA**

Ancorare la casetta alle fondamenta forando il pavimento nelle posizioni indicate e applicando apposite viti (viti non incluse).

**FIXAR O ABRIGO NUMA FUNDAÇÃO**

Afixe o abrigo à base abrindo buracos no chão nos locais previamente assinalados e aparafusando-o à mesma utilizando parafusos adequados (os parafusos não estão incluídos).

