



CODICE ARPC033

Casetta porta attrezzi in resina Artisan 9x7 Duotech

Dimensioni: cm 277x218x226



SITE PREPARATION | PRÉPARATION DU SITE | PREPARACIÓN DEL LUGAR | VORBEREITUNG DES AUFSTELLUNGSORTES | VOORBEREIDING VAN HET TERREIN | PREPARAZIONE DEL LUOGO DI MONTAGGIO | PREPARAÇÃO DO LOCAL

Level the ground surface | Égalisez la surface du sol | Nivela la superficie del suelo | Ebenen Sie die Bodenoberfläche | Maak de bodem vlak | Livella la superficie del terreno | Nivela a superfície do solo

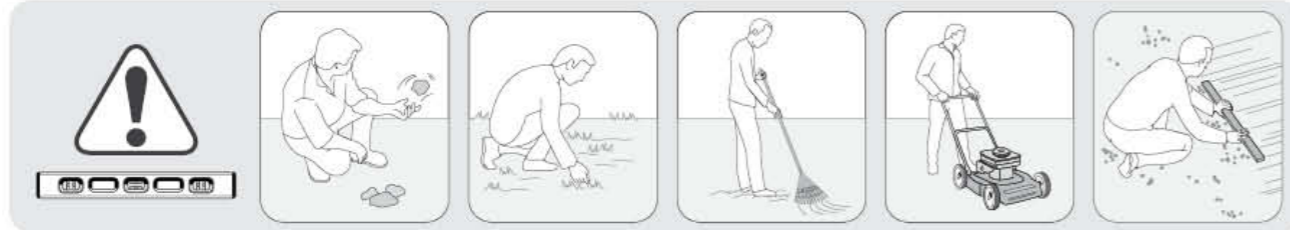

Recommendation: Construct a wooden or concrete base as a foundation | **Recommandation:** fabriquez une base en bois ou en béton en guise de fondation | **Recomendación:** construya una base de madera o de cemento a modo de cimiento | **Empfehlung:** Bauen Sie als Fundament eine Grundfläche aus Holz oder Beton | **Aanbeveling:** maak een houten of betonnen ondergrond als fundering | **Raccomandazione:** costruisci una base di legno o di cemento come fondamenta | **Recomendação:** Construa uma base de madeira ou de cimento como fundação

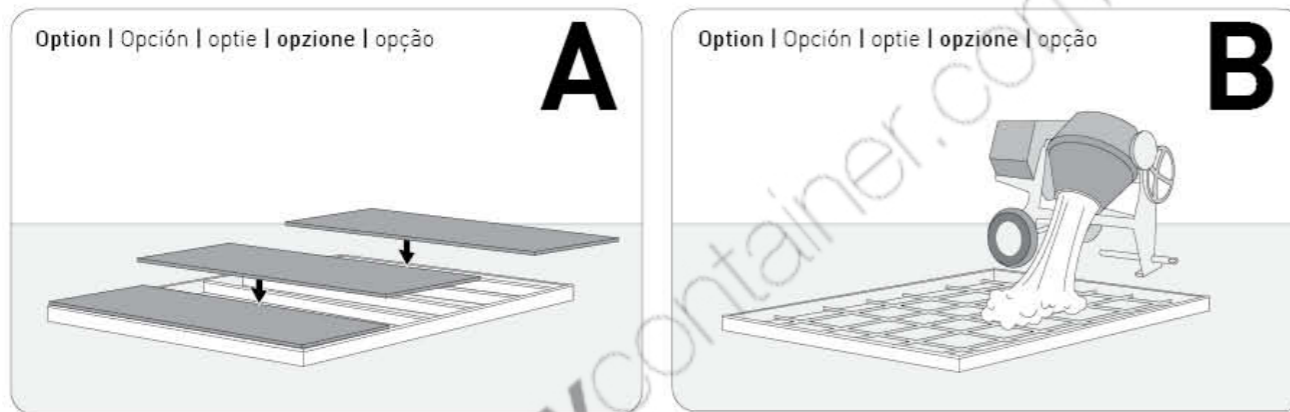

For external access during assembly, make sure to leave enough room around the outside of the shed assembly site.

Pour un accès externe au cours du montage, veillez à laisser suffisamment de place autour du site de montage.

Para tener un acceso exterior durante el montaje, asegúrese de dejar suficiente espacio alrededor del lugar de montaje del cobertizo.

Lassen Sie am Aufstellungsort außerhalb des Schuppens ausreichend Platz, so dass Sie während des Aufbaus von außen Zugang zum Schuppen haben.

Om tijdens de montage aan de buitenkant van het schuurtje te kunnen werken, moet u ervoor zorgen dat u genoeg ruimte laat aan de buitenkant van de montageplaats.

Per l'accesso esterno durante il montaggio, assicurati di lasciare abbastanza spazio intorno alla parte esterna del luogo di montaggio del deposito attrezzi.

Para ter acesso externo durante a montagem certifique-se de que deixa espaço suficiente em redor do exterior do local de montagem do abrigo.

External floor measurements are: | Les mesures externes de la étagé sont: | Las medidas del suelo externo son: | Die Außen-Bodenmaße betragen: | De afmetingen van de externe vloer zijn: | Le misure del pavimento esterno sono: | As medidas externas do chão são:



BEFORE STARTING ASSEMBLY | AVANT DE COMMENCER LE MONTAGE | ANTES DE EMPEZAR EL ARMADO | VOR MONTAGEBEGINN | VOORDAT U BEGINT TE MONTEREN | PRIMA DI INIZIARE IL MONTAGGIO | ANTES DE INICIAR A MONTAGEM

Read the care and safety guidelines at the end of this manual | Check to ensure that there are no missing or damaged parts BEFORE starting or arranging assembly | Review all assembly instructions | Assemble all the parts according to the directions in this manual. Do not skip any steps.

Lisez les instructions de précaution et de sécurité à la fin de ce manuel | Assurez-vous qu'il n'y a pas de pièces manquantes ou endommagées AVANT de commencer ou d'organiser l'assemblage | Lisez toutes les instructions de montage | Assemblez toutes les pièces selon les instructions de ce manuel. Ne sautez aucune étape.

Lea las intrucciones de precauciones y seguridad que están al final de este manual | Asegúrese de que no faltan piezas ni están dañadas ANTES de comenzar o disponer el montaje | Revise todas las instrucciones de montaje | Monte todas las piezas según las instrucciones de este manual. No se saltee ningún paso.

Lesen Sie die Sicherheitsrichtlinien am Ende des Benutzerhandbuchs durch | Prüfen Sie bitte VOR dem Zusammenbau, dass keine Teile beschädigt sind oder fehlen | Gehen Sie noch einmal die komplette Aufbauanleitung durch | Bauen Sie alle Teile entsprechend der Anleitung in diesem Handbuch zusammen. Lassen Sie dabei keinen Arbeitsschritt aus.

Lees de richtlijnen voor zorg en veiligheid achterin deze handleiding | Controleer dat er geen onderdelen mankeren, of beschadigd zijn, VOORDAT u met de montage begint | Bekijk alle montagehandleidingen | Monteer alle onderdelen volgens de aanwijzingen van deze handleiding. Sla geen stappen over.

Leggi le linee guida di assistenza e sicurezza alla fine di questo manuale | Verificare per assicurarsi che non ci siano parti mancanti o danneggiate PRIMA di iniziare o di disporre il montaggio | Consulta tutte le istruzioni di montaggio | Monta tutti i componenti secondo le istruzioni contenute in questo manuale. Non saltare nessuna fase.

Leia as diretrizes de cuidados e segurança que constam da parte final deste manual | Verifique para se assegurar de que não há peças em falta ou danificadas ANTES de começar a preparar a montagem | Reveja todas as instruções de montagem | Monte todas as peças de acordo com as instruções do manual. Não salte quaisquer passos.

REQUIRED TOOLS | OUTILS EXIGÉS | HERRAMIENTAS NECESARIAS | BENÖTIGTE WERKZEUGE | BENODIGD GEREEDSCHAP | ATTREZZATURA OCCORRENTE | FERRAMENTAS NECESSÁRIAS

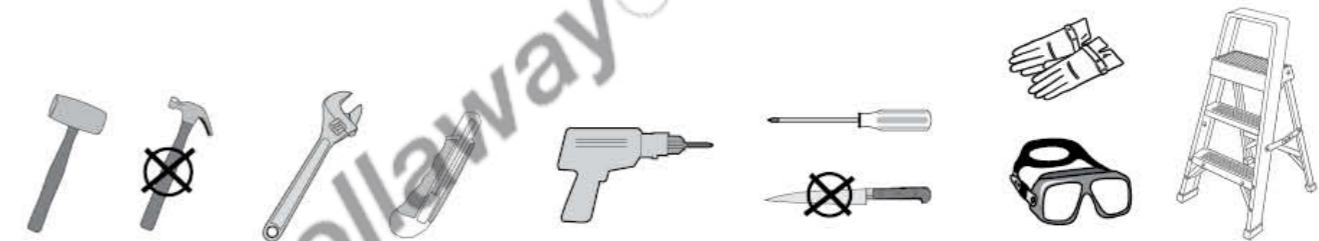

ASSEMBLY REQUIRES TWO PEOPLE | LE MONTAGE DOIT ÊTRE EFFECTUÉ PAR DEUX PERSONNES | SE NECESITAN DOS PERSONAS PARA ARMARLO | ZWEI PERSONEN ZUR MONTAGE NOTWENDIG | MONTAGE VEREIST TWEE PERSONEN | MONTAGGIO RICHIEDE DUE PERSONE | A MONTAGEM EXIGE DUAS PESSOAS

SHED PARTS | PIÈCES DE L'ABRI | PARTES DEL COBERTIZO | TEILE DES SCHUPPENS | ONDERDELEN VAN HET SCHUURTJE | COMPONENTI DEL DEPOSITO ATTREZZI | PEÇAS DO ABRIGO

Remove all parts from the package(s) and spread them out on a clean work surface | Code letters are imprinted on each part for easy identification | Retirez toutes les pièces du/des paquet(s) et étalez-les sur une surface de travail propre | Des lettres sont imprimées sur chaque pièce pour une identification facile | Saque todas las piezas del paquete o paquetes y póngalas sobre una superficie de trabajo limpia | El código de letras está marcado en cada pieza para que sea más fácil identificarla | Nehmen Sie alle Teile aus der Verpackung und breiten Sie sie auf einer sauberen Arbeitsfläche aus | Auf jedem Teil sind Kennbuchstaben aufgedruckt, die die Zuordnung der einzelnen Teile erleichtern | Haal alle onderdelen uit het pakket (of uit de pakketten) en leg ze op een schoon werkoppervlak | Op ieder onderdeel zijn codes aangebracht voor een gemakkelijke identificatie | Rimuovi tutti i componenti dal pacchetto (i) e spargili su una superficie di lavoro pulita | Le lettere del codice sono state stampate su ciascun componente per una facile identificazione | Retire todas as peças da embalagem e espalhe-as numa superfície de trabalho limpa | Existem letras de código impressas em cada peça para fácil identificação

FLOOR PARTS | ÉLÉMENTS DU PLANCHER | PARTES DEL SUELO | BODENTEILE | VLOERPANELEN | PARTI DEL PAVIMENTO | PEÇAS DO CHÃO

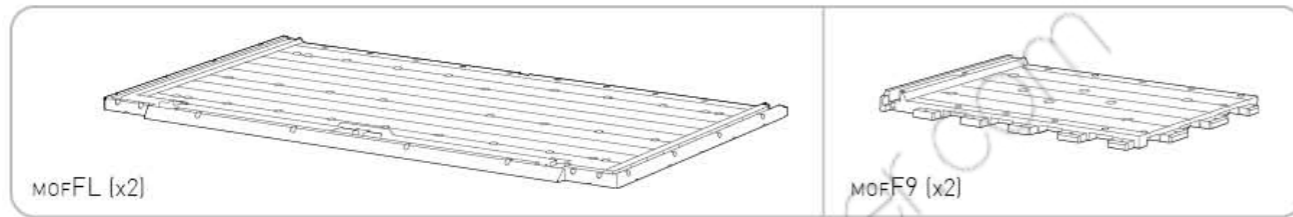

WALL PARTS | PIÈCES DU CONTOUR | PARTES DE LAS PAREDES | WANDELEMENTE | MUURONDERDELEN | PARTI DELLA PARETE | PAINÉIS LATERAIS

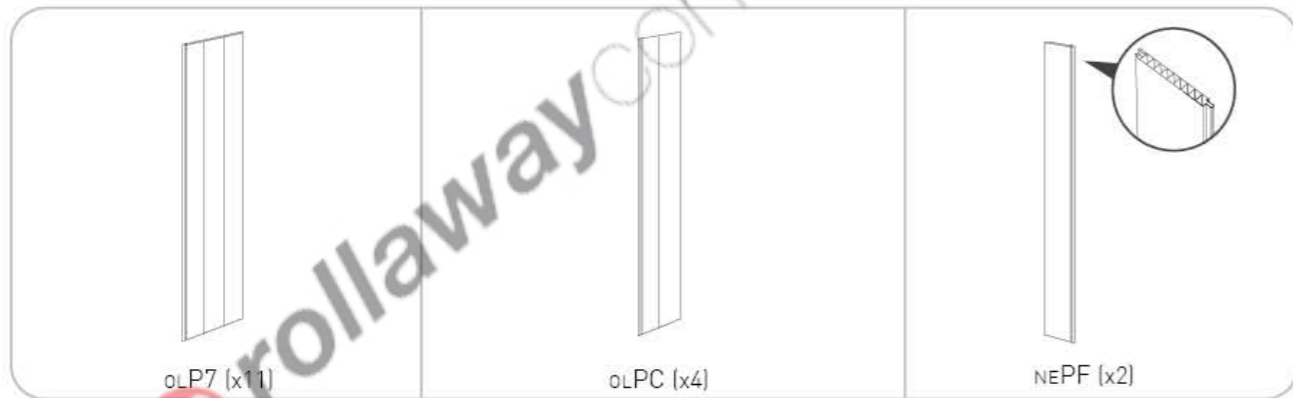

DOOR PARTS | PIÈCES DE LA PORTE | PARTES DE LA PUERTA | TÜRELEMENTE | DEURONDERDELEN | PARTI DELLA PORTA | PEÇAS DAS PORTAS

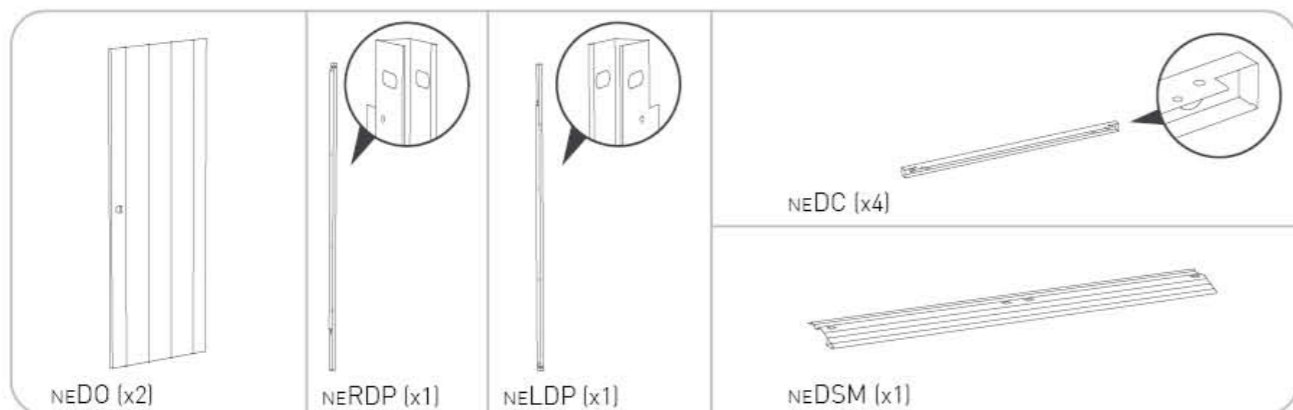

ROOF PARTS | PIÈCES DU TOIT | PARTES DEL TECHO | DACHELEMENTE | DAKONDERDELEN | PARTI DEL TETTO | PEÇAS DO TELHADO

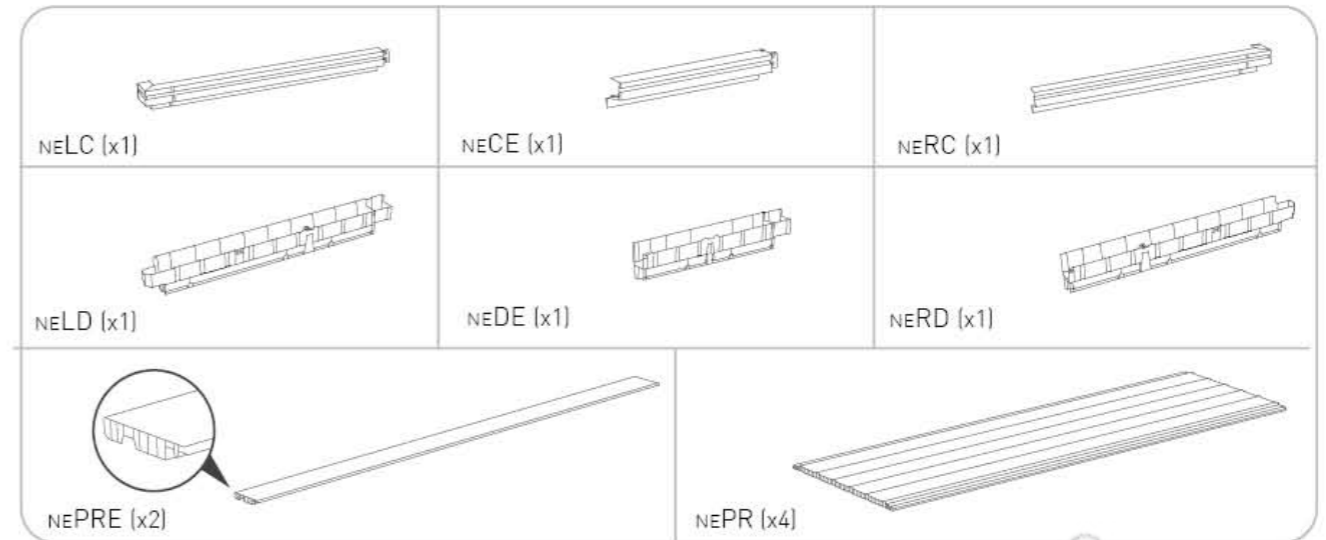

METAL PARTS | PIÈCES MÉTALLIQUES | PIEZAS METÁLICAS | METALLTEILE | METALEN DELEN | PARTI IN METALLO | PARTES METÁLICAS

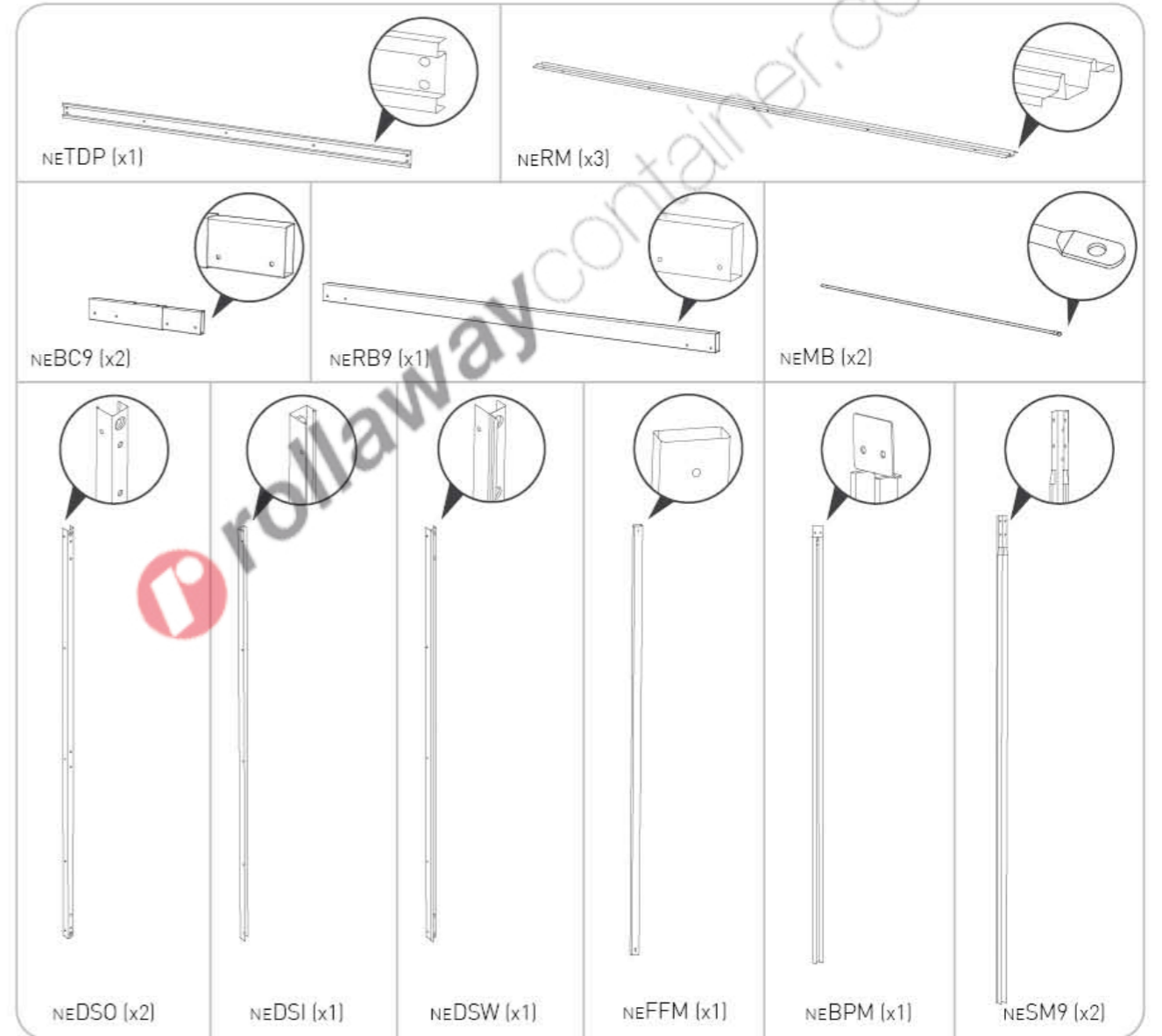

WINDOW PARTS | PIÈCES DE LA FENÊTRE | PARTES DE LA VENTANA | FENSTERELEMENTE | VENSTERONDERDELEN | PARTI DELLA FINESTRA | PEÇAS DA JANELA

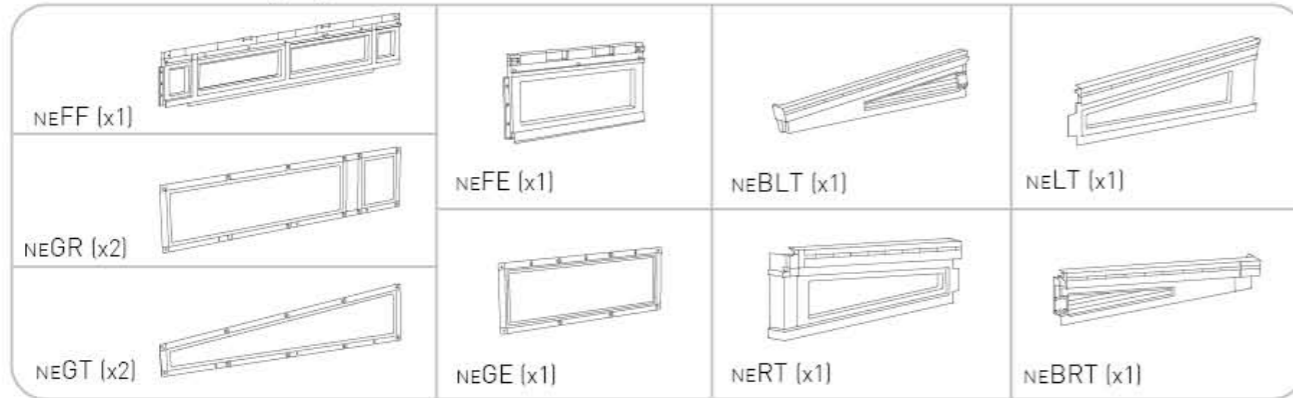

SMALL PARTS | PETITES PIÈCES | PARTES PEQUEÑAS | KLEINTEILE | KLEINE ONDERDELEN | MINUTERIA | PEÇAS PEQUENAS

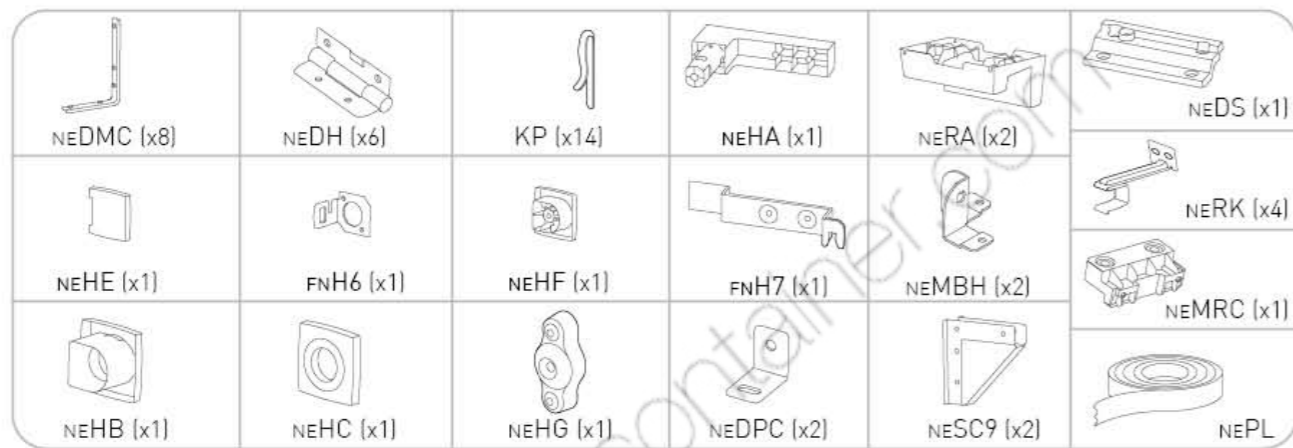

SCREWS | VIS | TORNILLOS | SCHRAUBEN | SCHROEVEN | VITI | PARAFUSOS

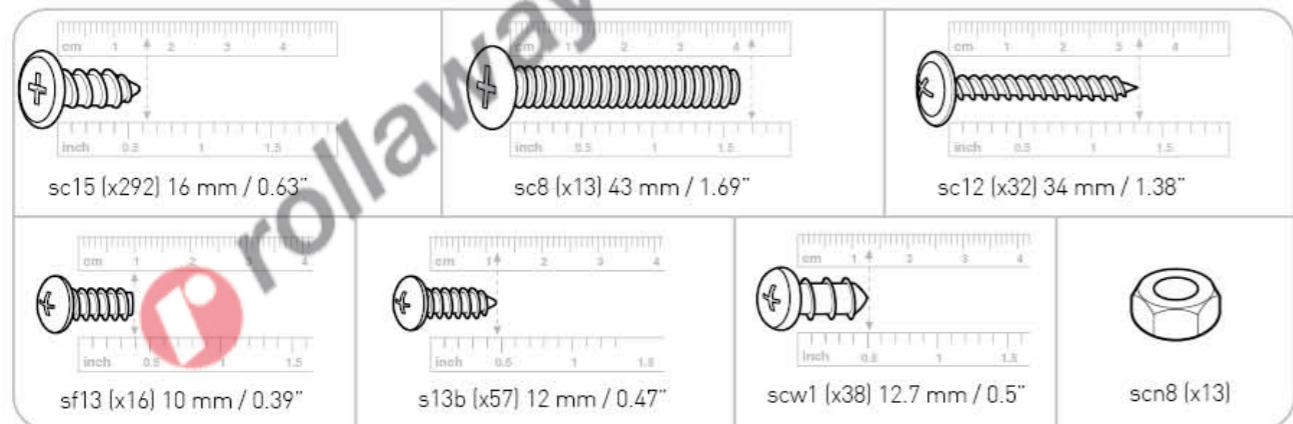

Packaging may contain some additional small parts for use as spare parts | L'emballage peut contenir de petites pièces supplémentaires à utiliser comme pièces de rechange | El envoltorio puede contener algunas piezas pequeñas adicionales que se pueden utilizar como repuestos | In der Verpackung können kleine Zusatzteile enthalten sein, die als Ersatzteile genutzt werden können | De verpakking kan een aantal kleine extra onderdelen bevatten, die als reserveonderdeel gebruikt kunnen worden | La confezione potrebbe contenere piccole parti supplementari da utilizzare come parti di ricambio | A embalagem pode conter algumas pequenas peças adicionais para utilização como peças de reposição

NOTE: Due to variations in production, the actual assembled size may vary slightly from the specified dimensions.

REMARQUE: En raison de variantes dans la production, la taille de montage réelle peut différer quelque peu des dimensions indiquées.

NOTA: debido a las variaciones en la producción, el tamaño real al montarlo puede variar ligeramente con respecto a las dimensiones especificadas.

BITTE BEACHTEN: Aufgrund von Abweichungen in der Herstellung kann die tatsächliche Größe leicht von den angegebenen Maßen abweichen.

LET OP: vanwege afwijkingen in de productie kan de werkelijke afmeting na montage een klein beetje afwijken van de opgegeven afmetingen.

NOTA: a causa di variazioni nella produzione, la dimensione effettiva del prodotto assemblato può variare leggermente dalle dimensioni menzionate.

NOTA: Devido a variações na produção o tamanho real da montagem poderá variar ligeiramente das dimensões especificadas.

FLOOR ASSEMBLY | MONTAGE DU SOL | ARMADO DEL PISO | MONTAGE DER BODENPLATTE | VLOERMONTAGE | MONTAGGIO DEL PAVIMENTO | MONTAGEM DO PISO

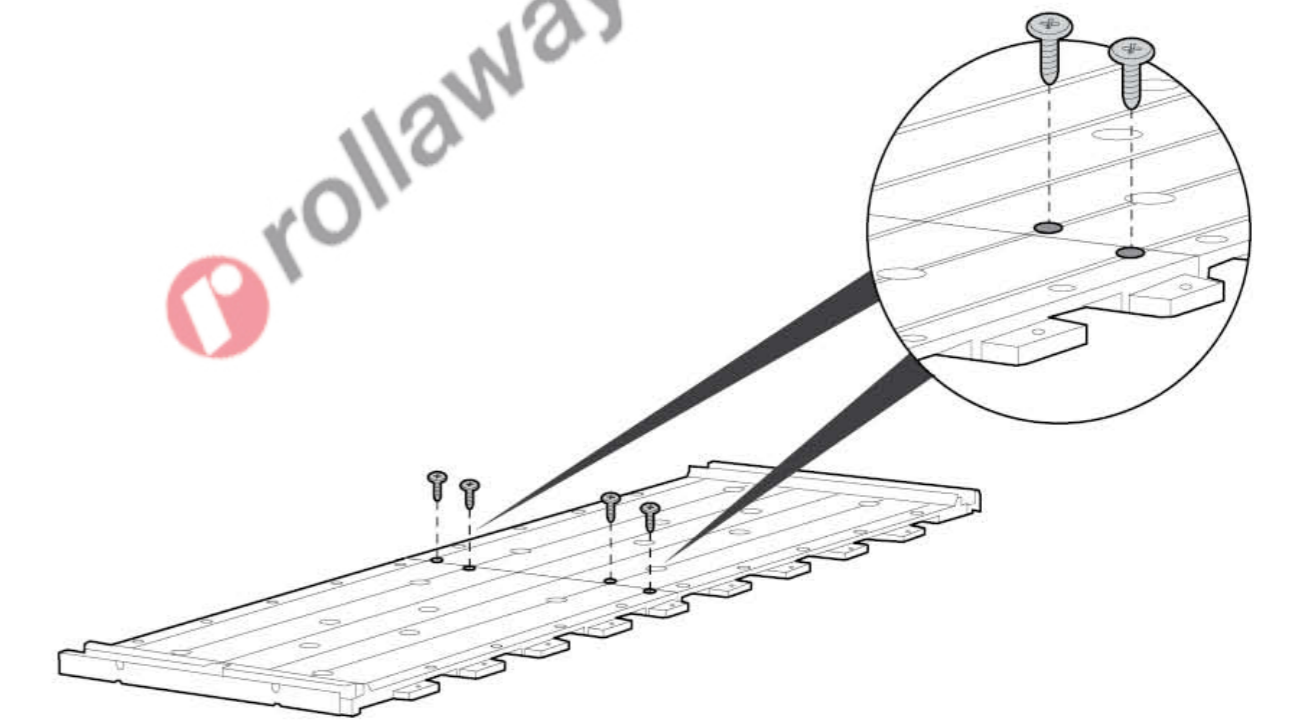
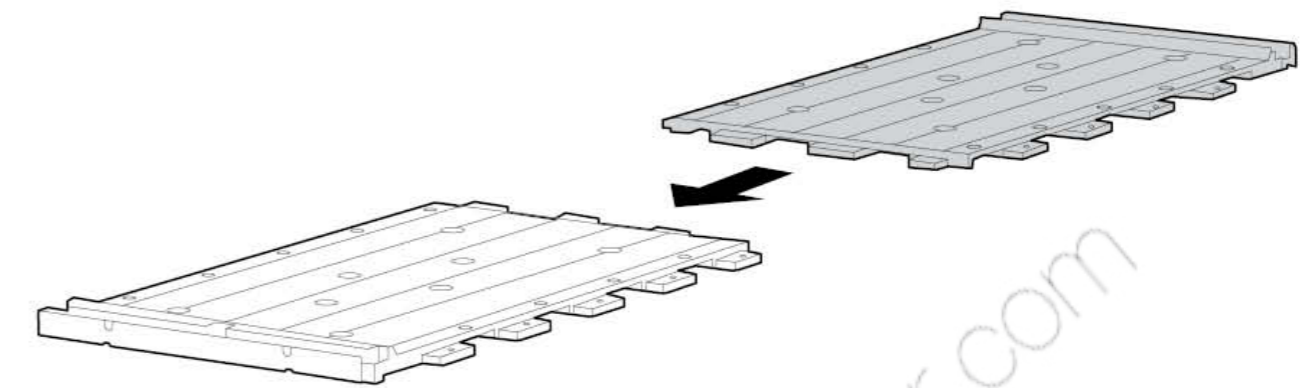

3

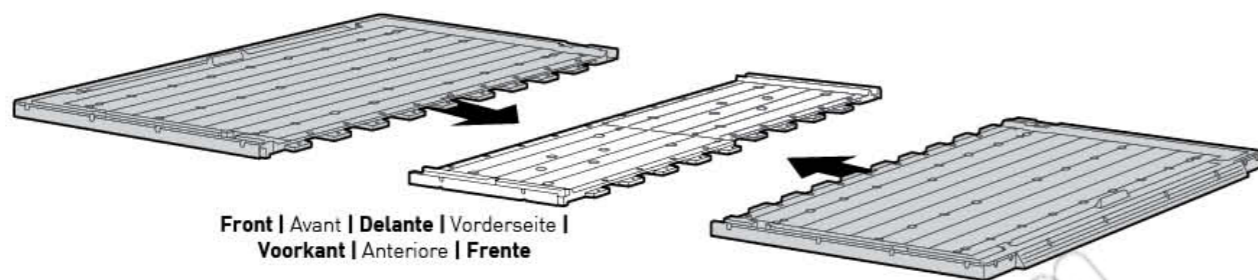

4

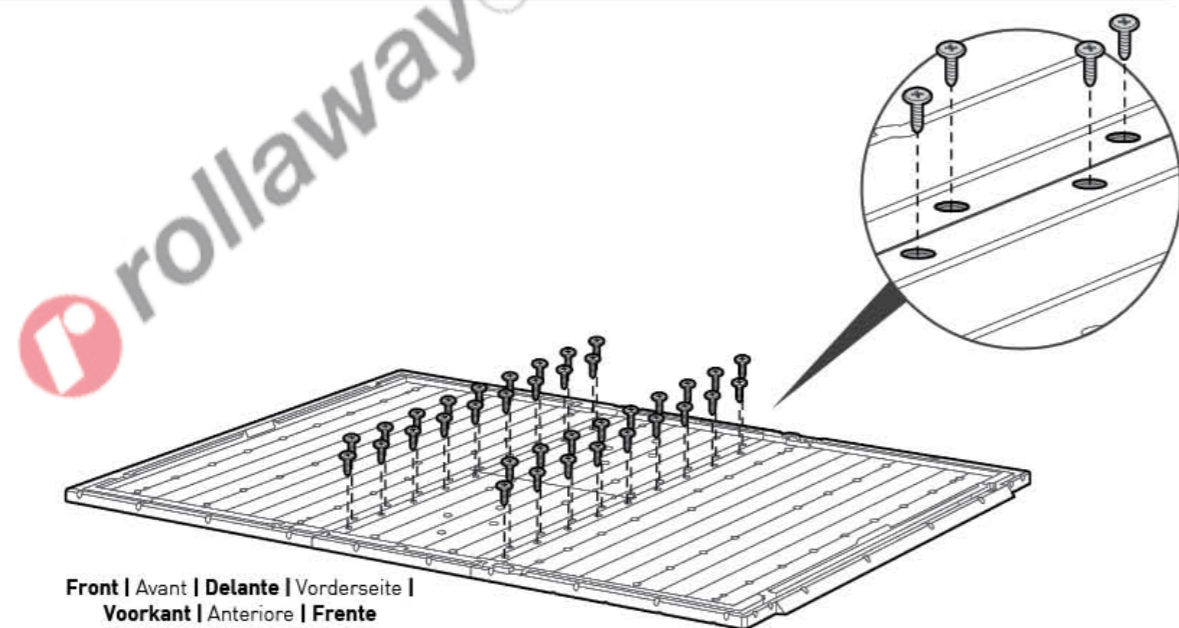

WALL ASSEMBLY | MONTAGE DU MUR | ARMADO DE PAREDES | MONTAGE DER WÄNDE | MONTAGE VAN DE MUREN | ASSEMBLAGGIO DELLE PARETI | MONTAGEM DA PAREDE

5

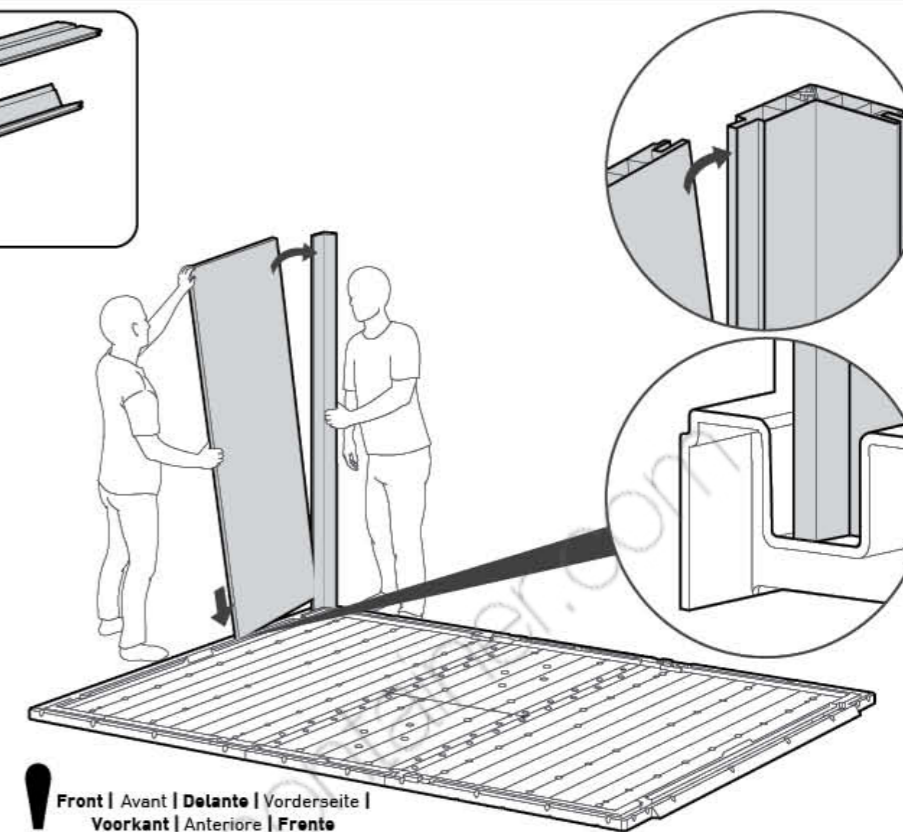
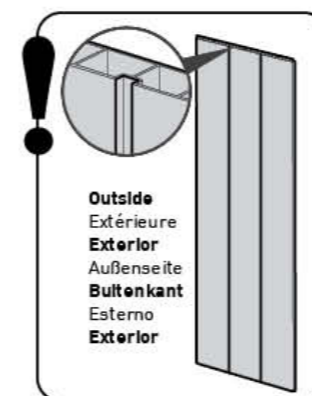
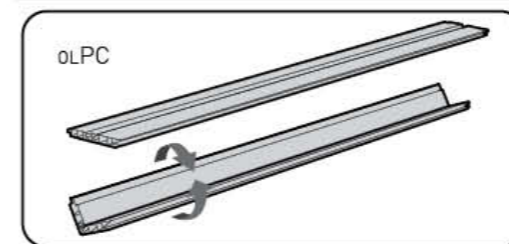
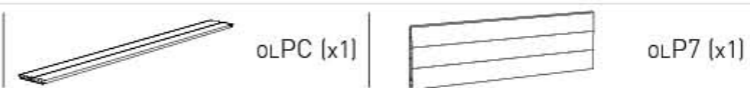

6

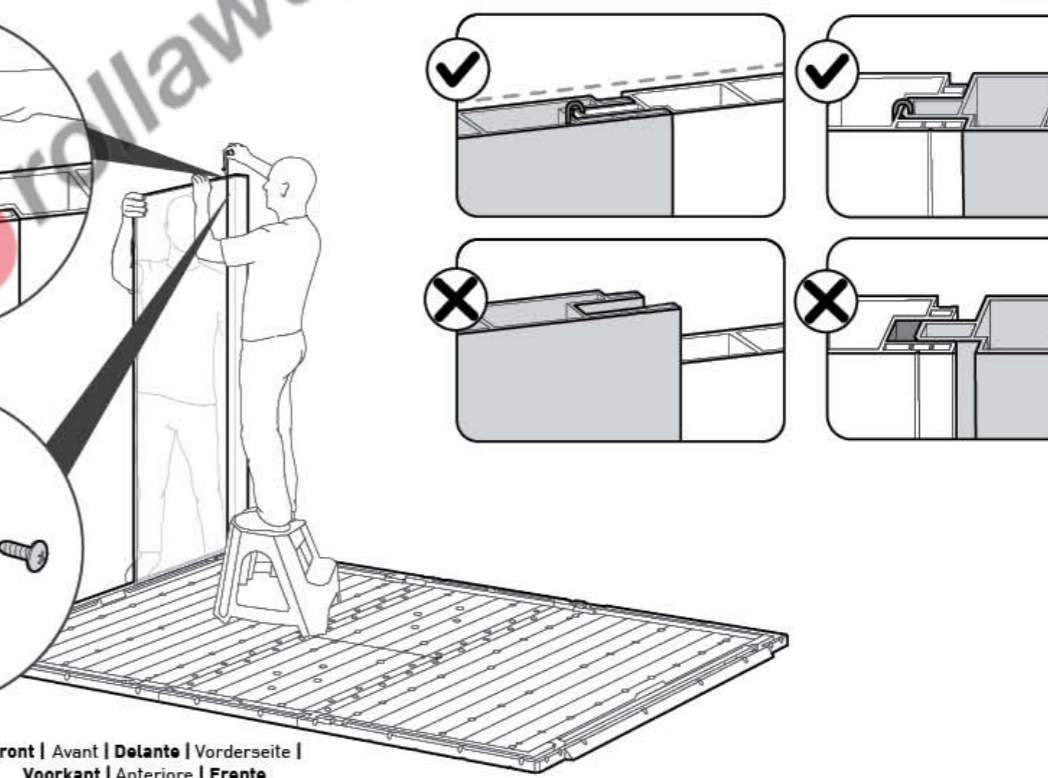
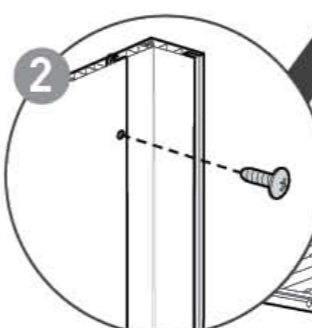
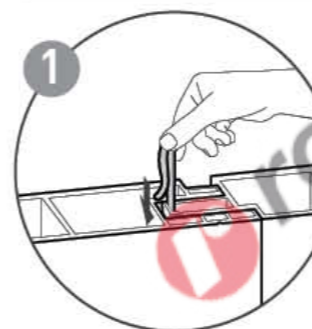

7



oLP7 (x1)

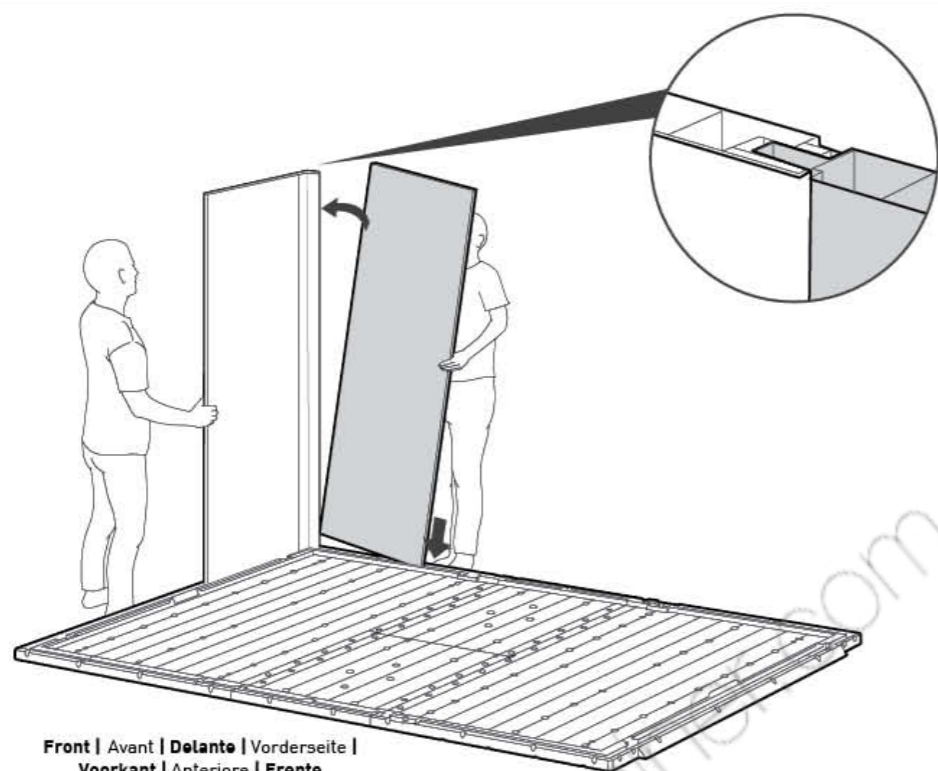

Front | Avant | Delante | Vorderseite |
Voorkant | Anteriore | Fronte

8



KP (x1)



s13b (x1)

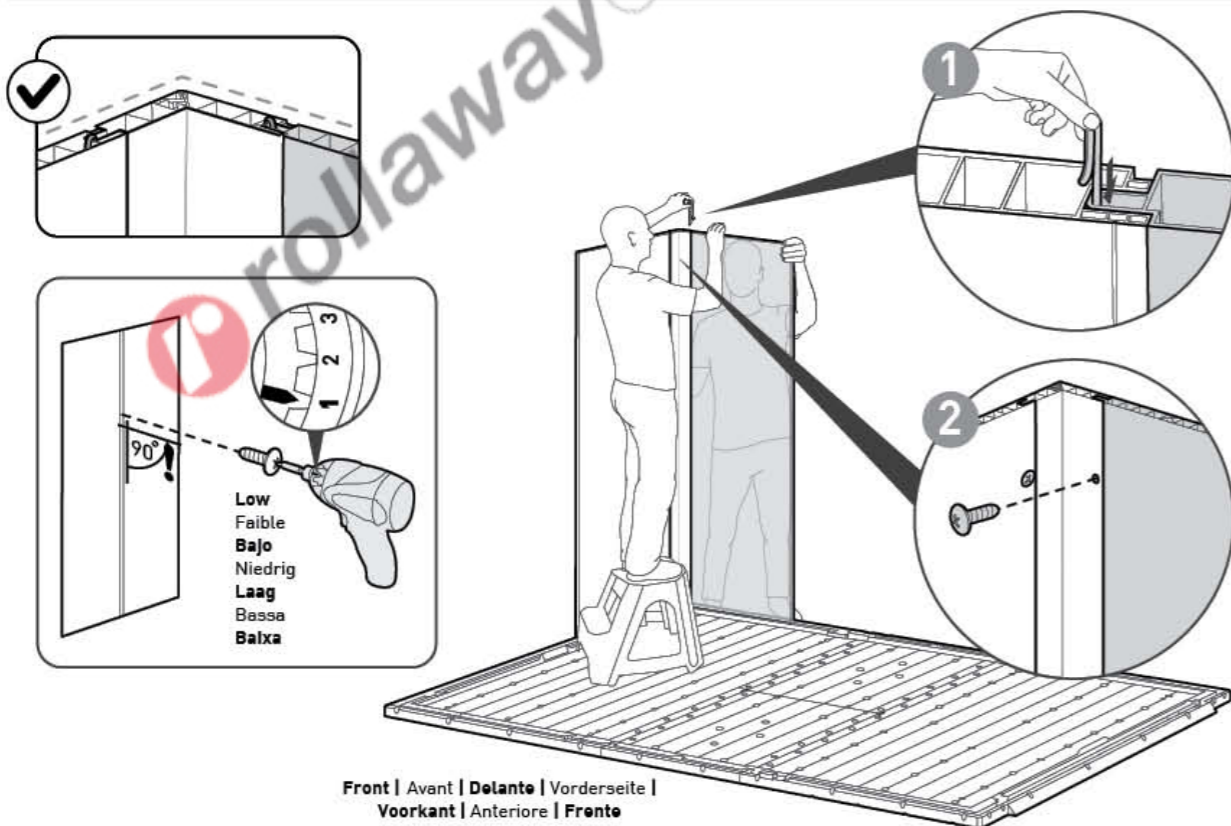

Front | Avant | Delante | Vorderseite |
Voorkant | Anteriore | Fronte

9



oLP7 (x3)



KP (x3)

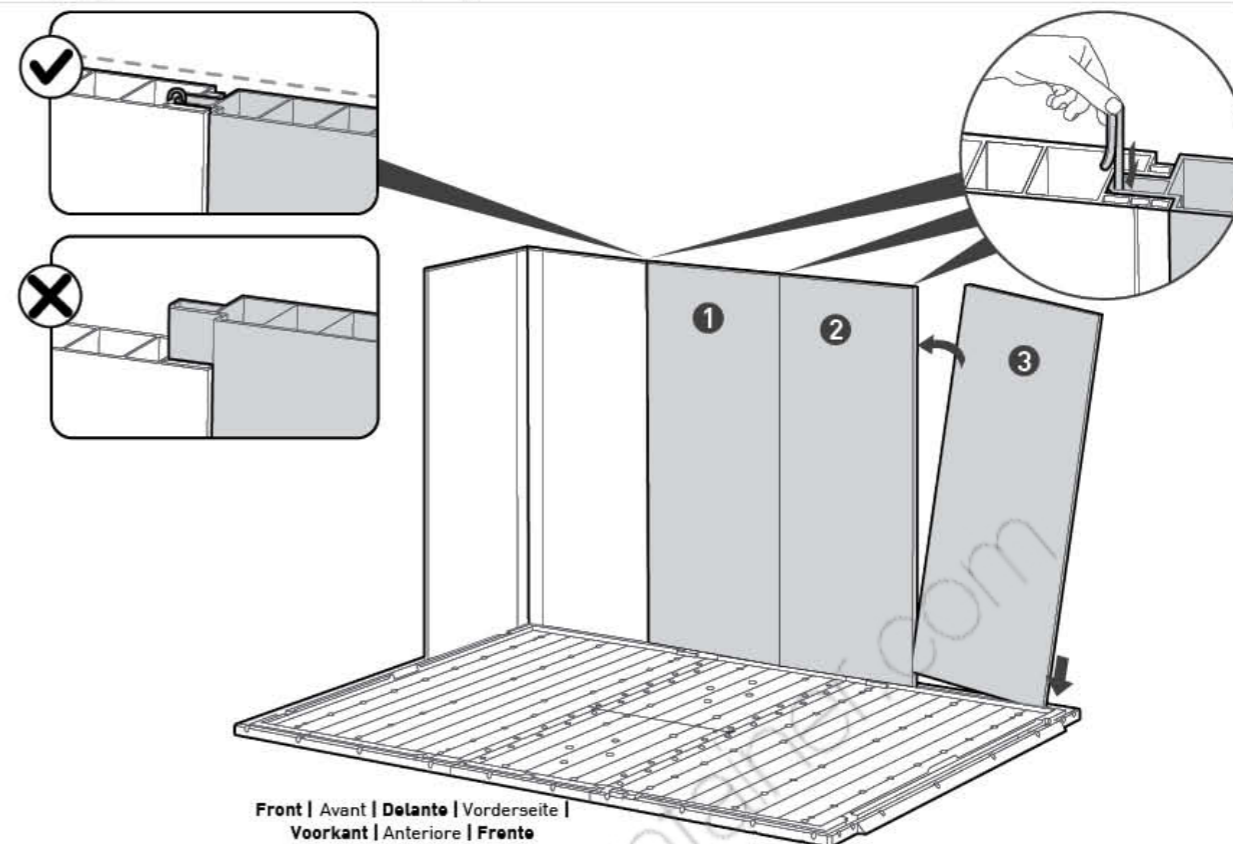

Front | Avant | Delante | Vorderseite |
Voorkant | Anteriore | Fronte

10



oLPC (x1)



KP (x1)



s13b (x1)

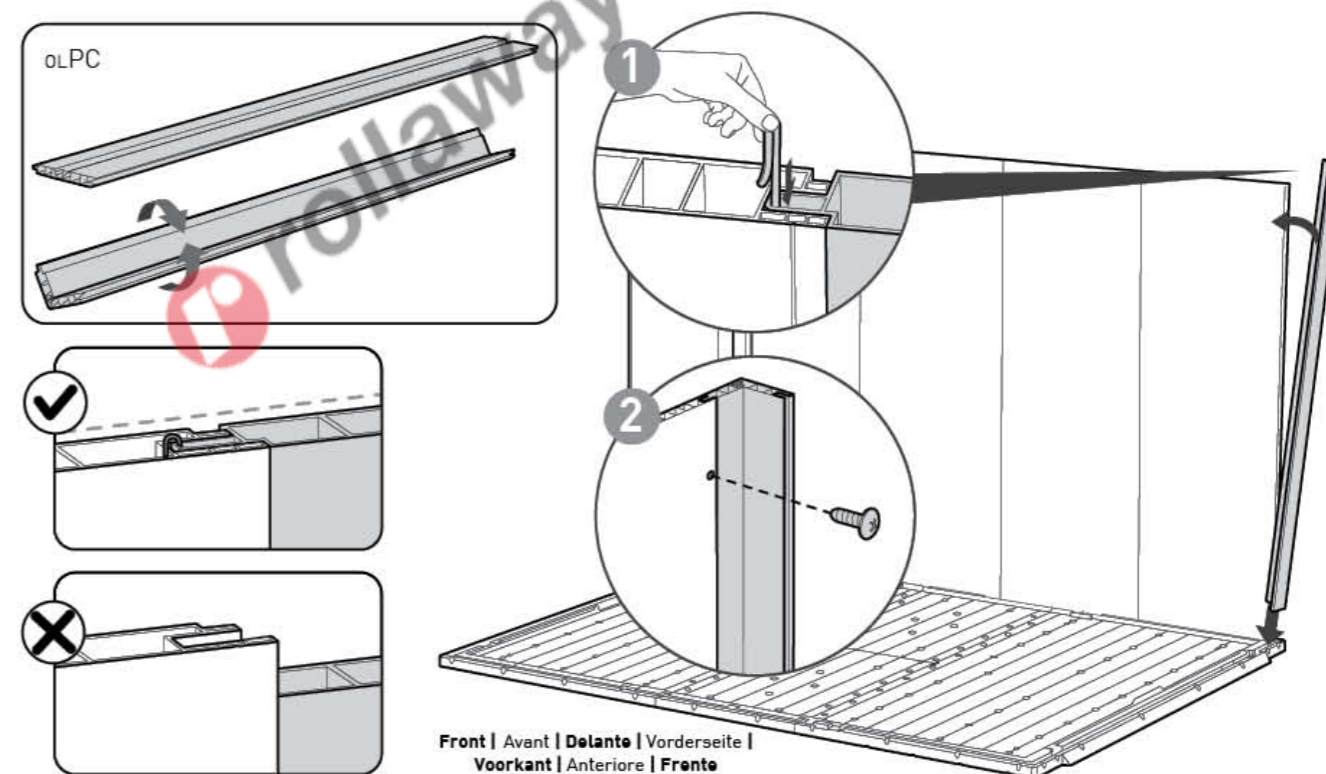

Front | Avant | Delante | Vorderseite |
Voorkant | Anteriore | Fronte

11



oLP7 (x1)



KP (x1)



s13b (x1)

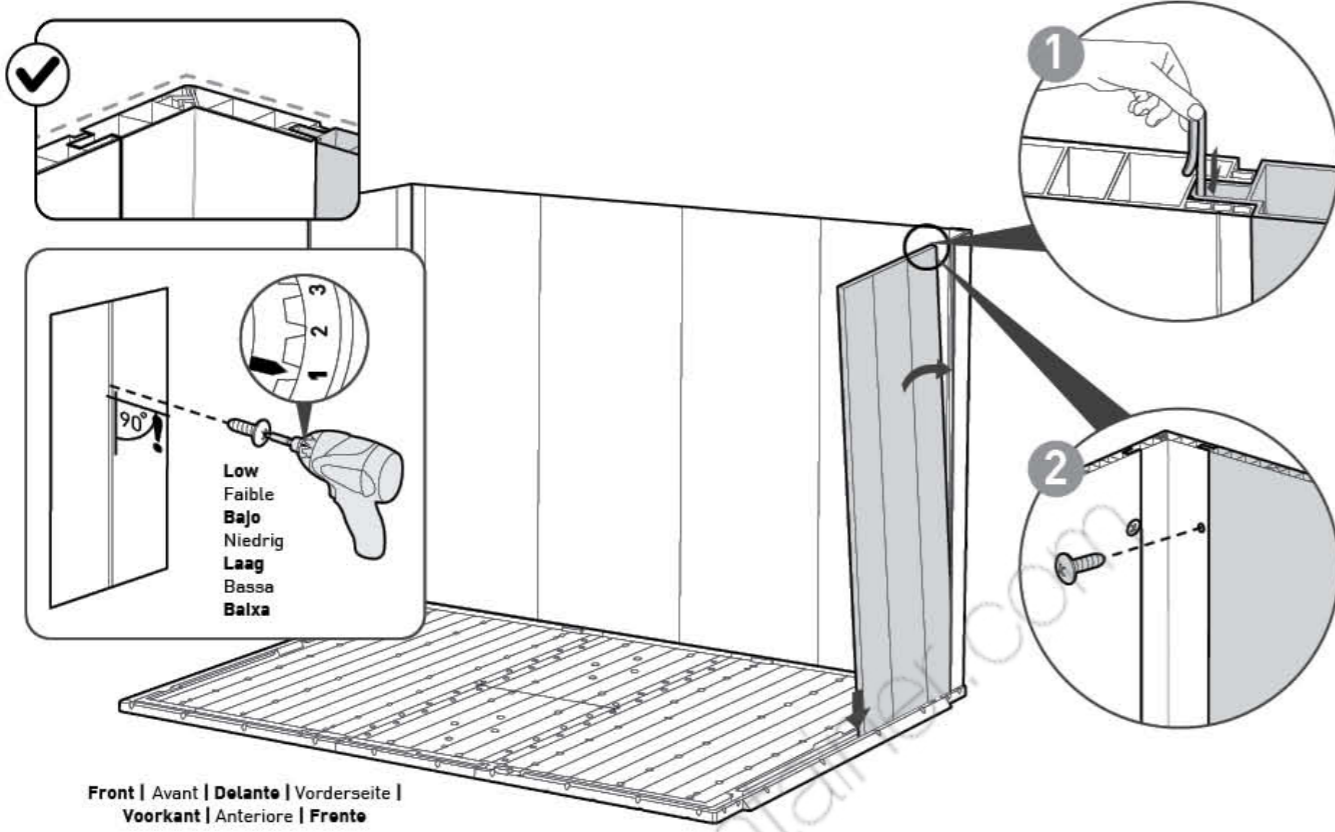

12



oLP7 (x2)



KP (x2)

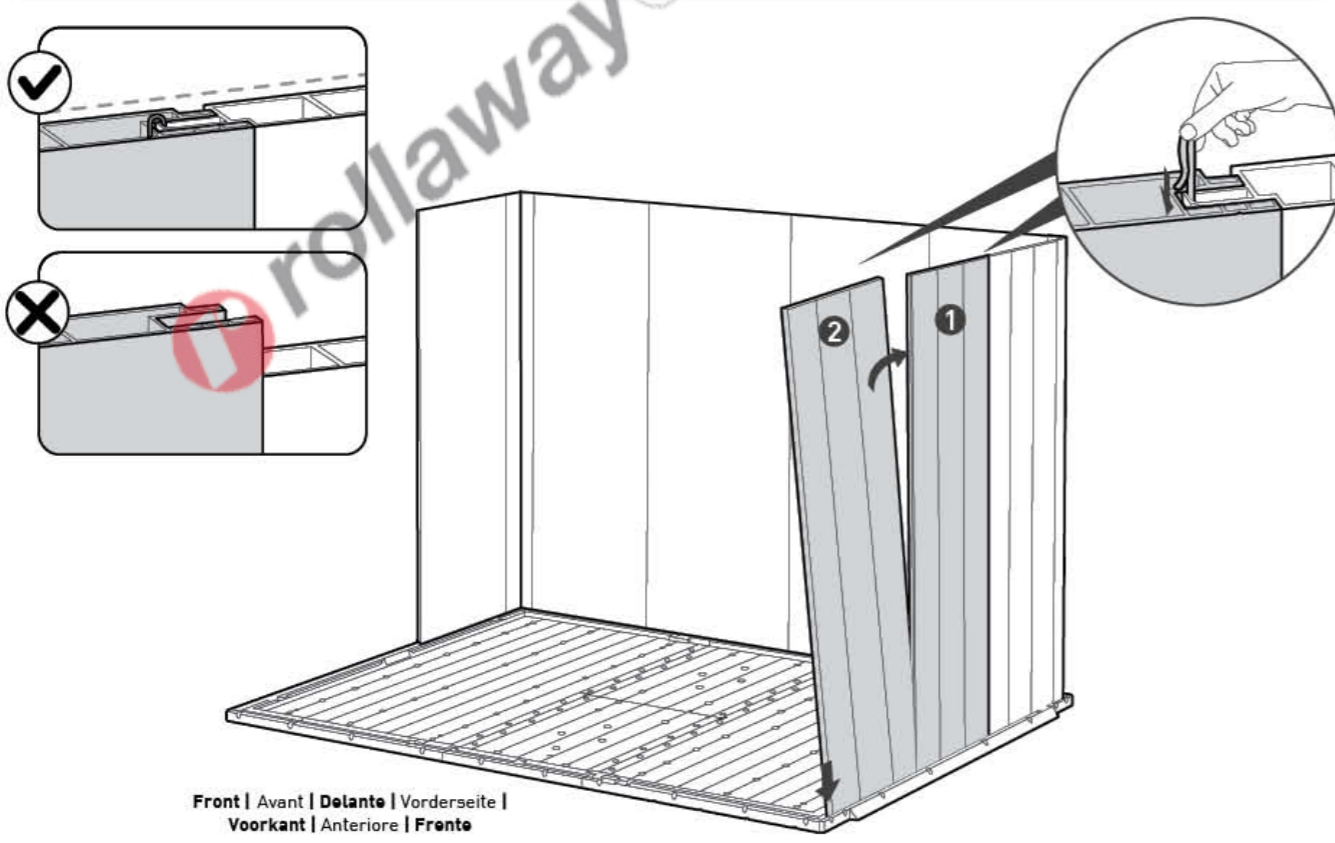

13



oLPC (x1)



KP (x1)

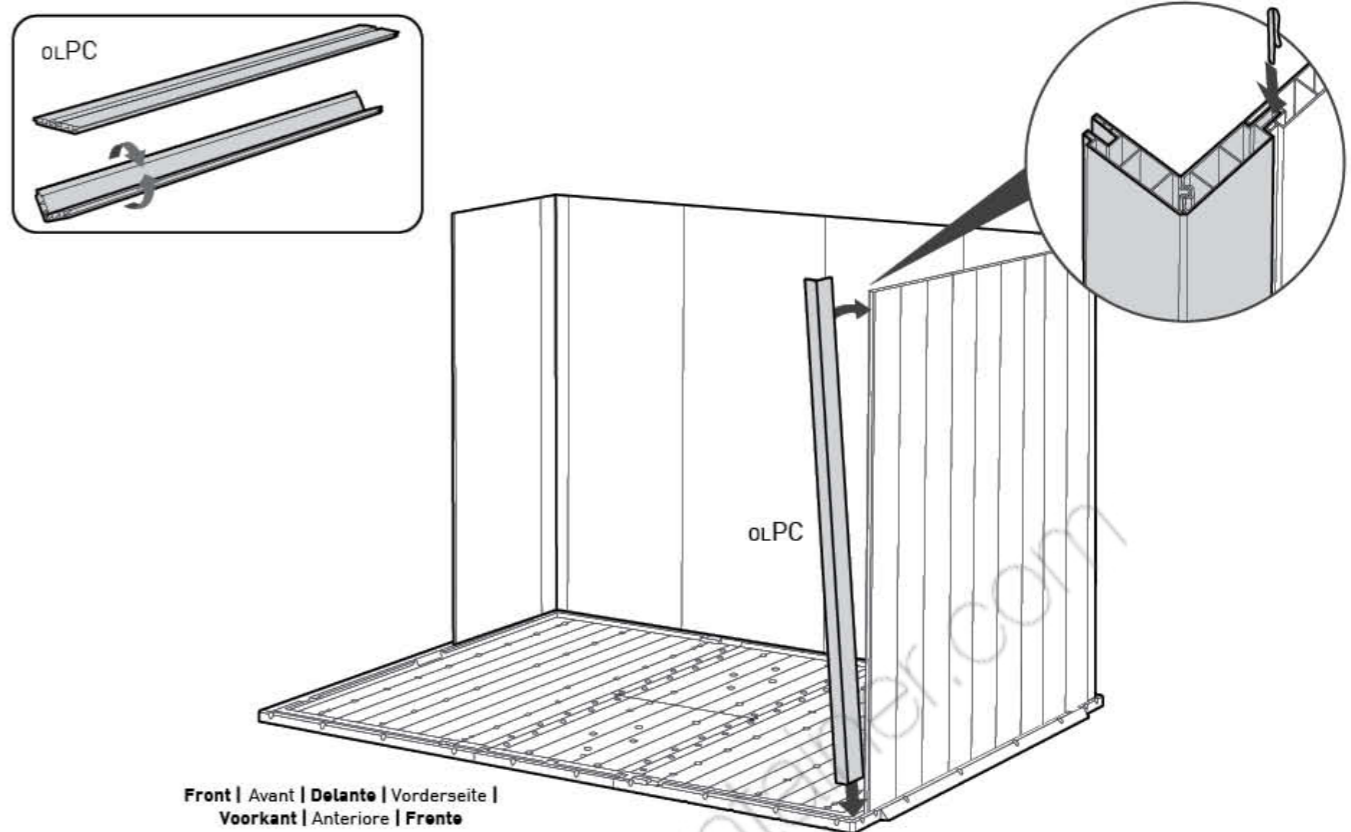

14



s13b (x2)

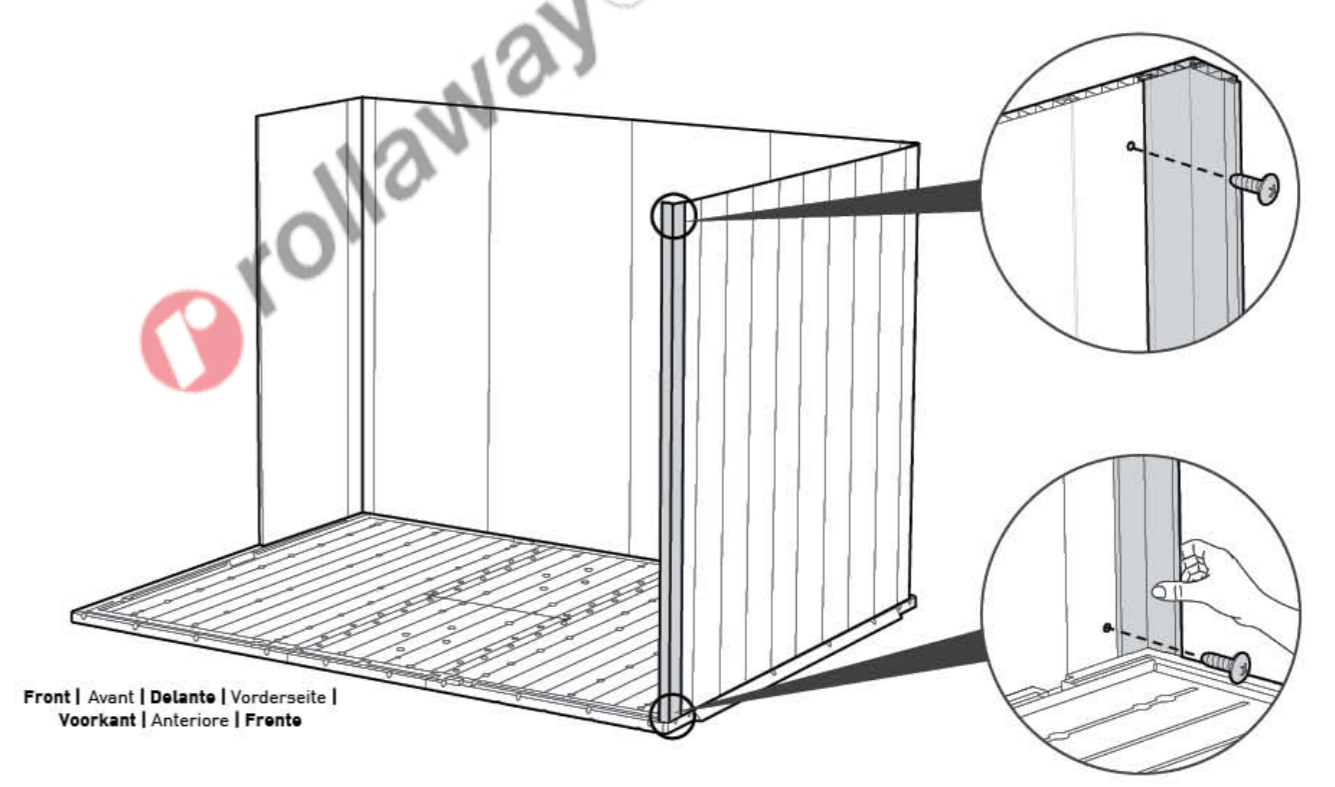

15



oLP7 (x2)



KP (x2)

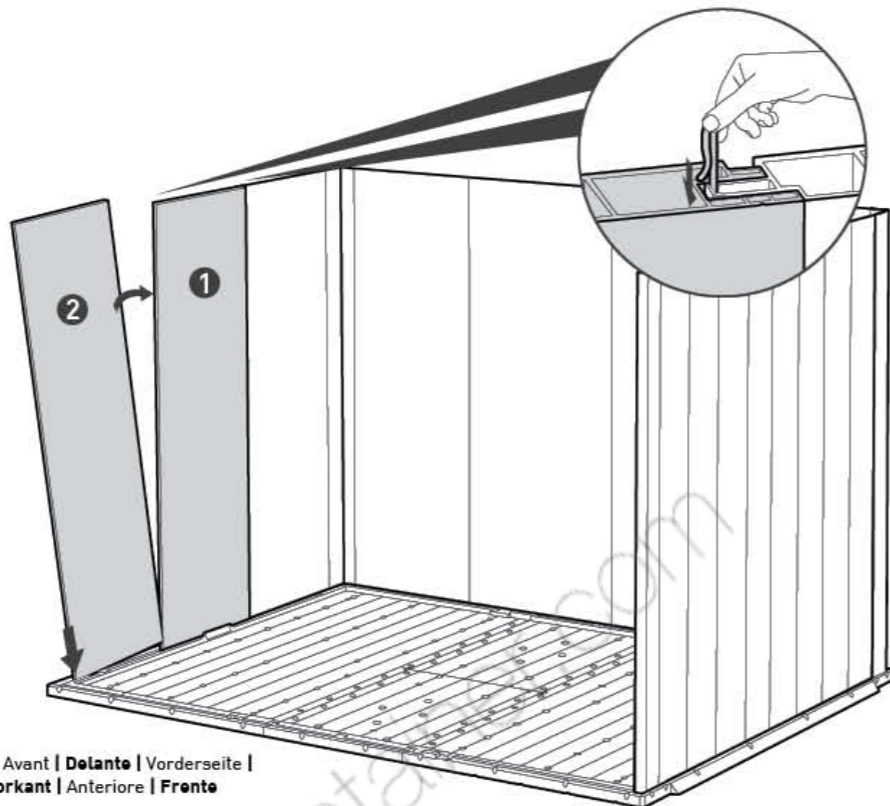
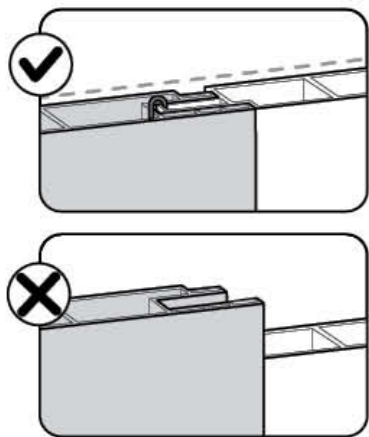

16



oLPC (x1)



KP (x1)

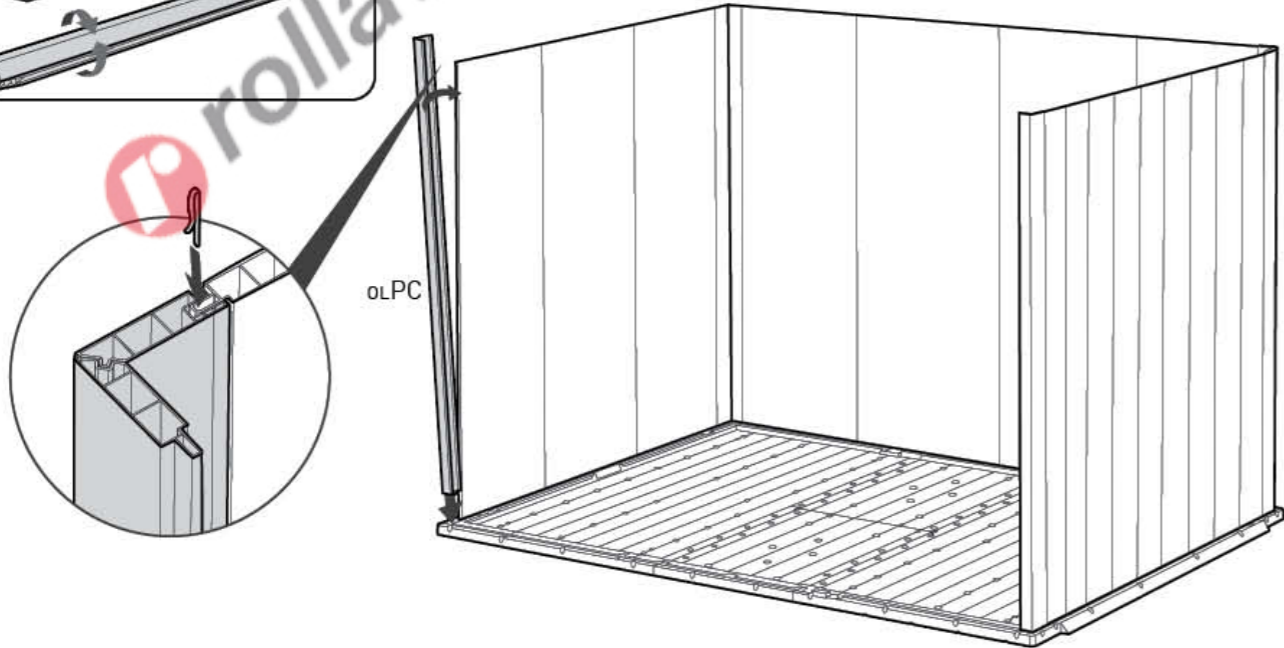
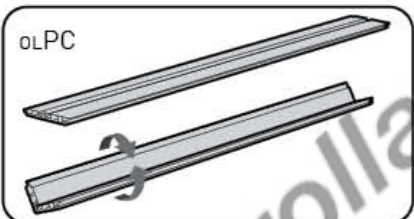

17



s13b (x2)

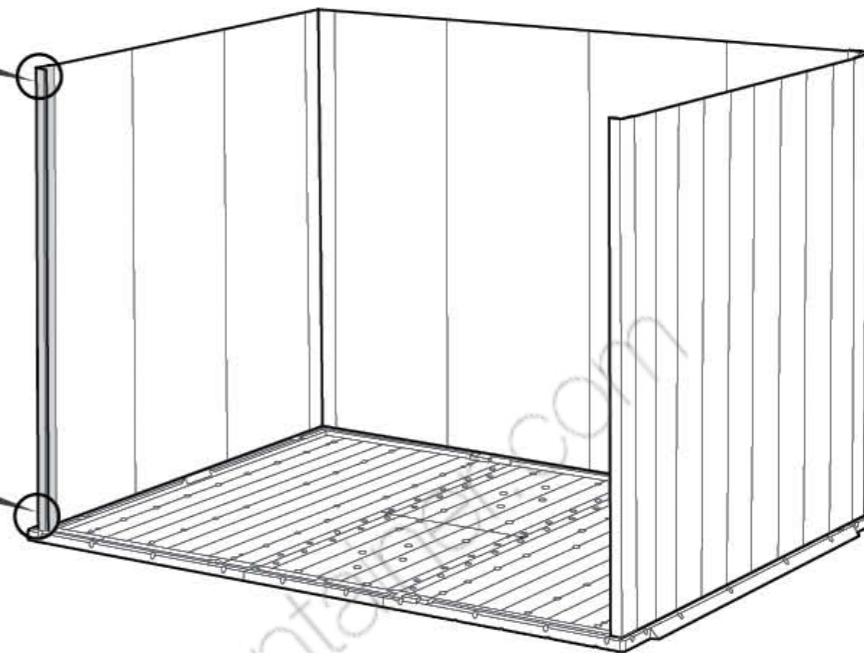
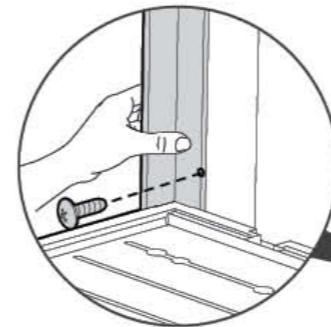
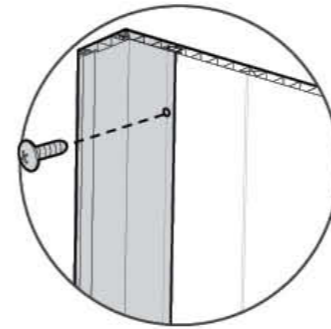

18



oLP7 (x1)



KP (x1)

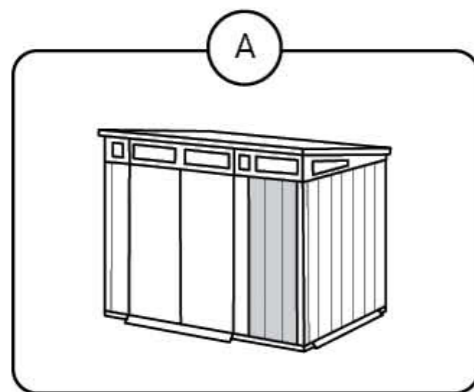

OR

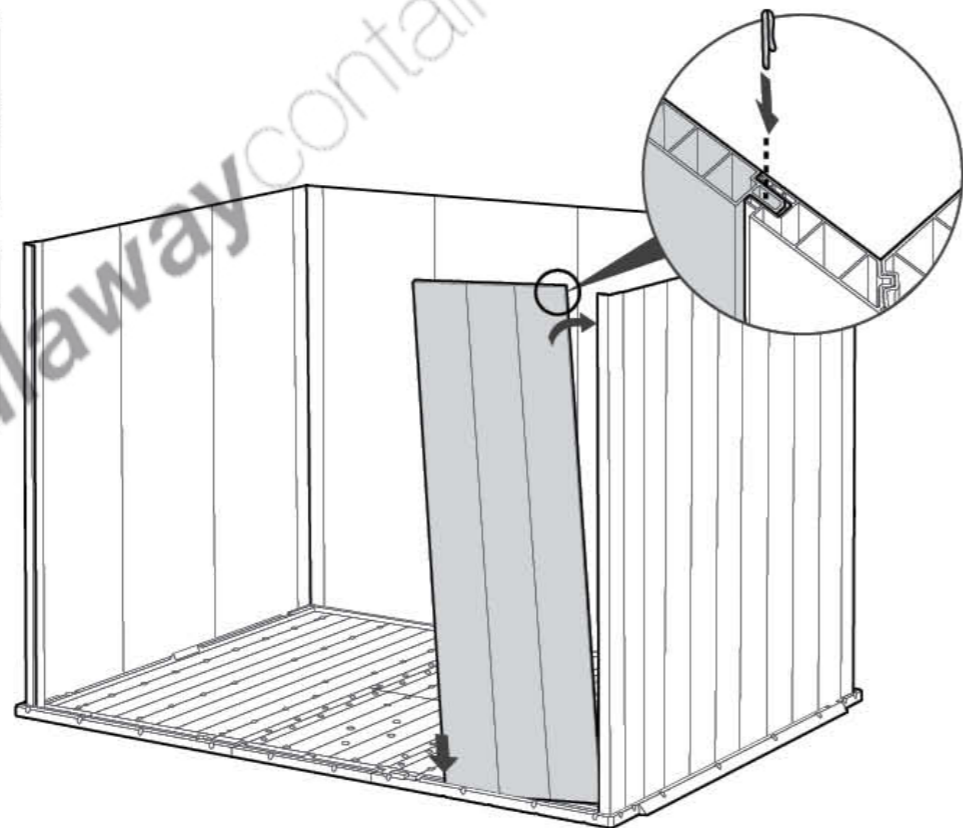
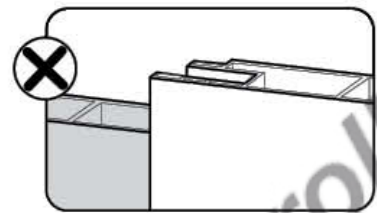
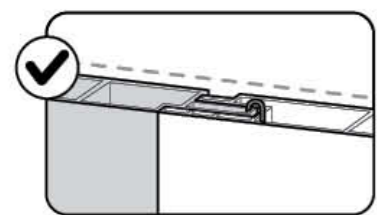
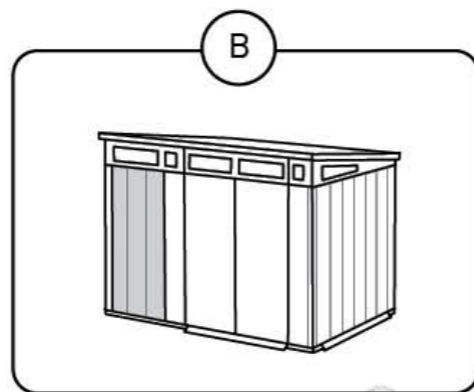

19



s13b (x2)

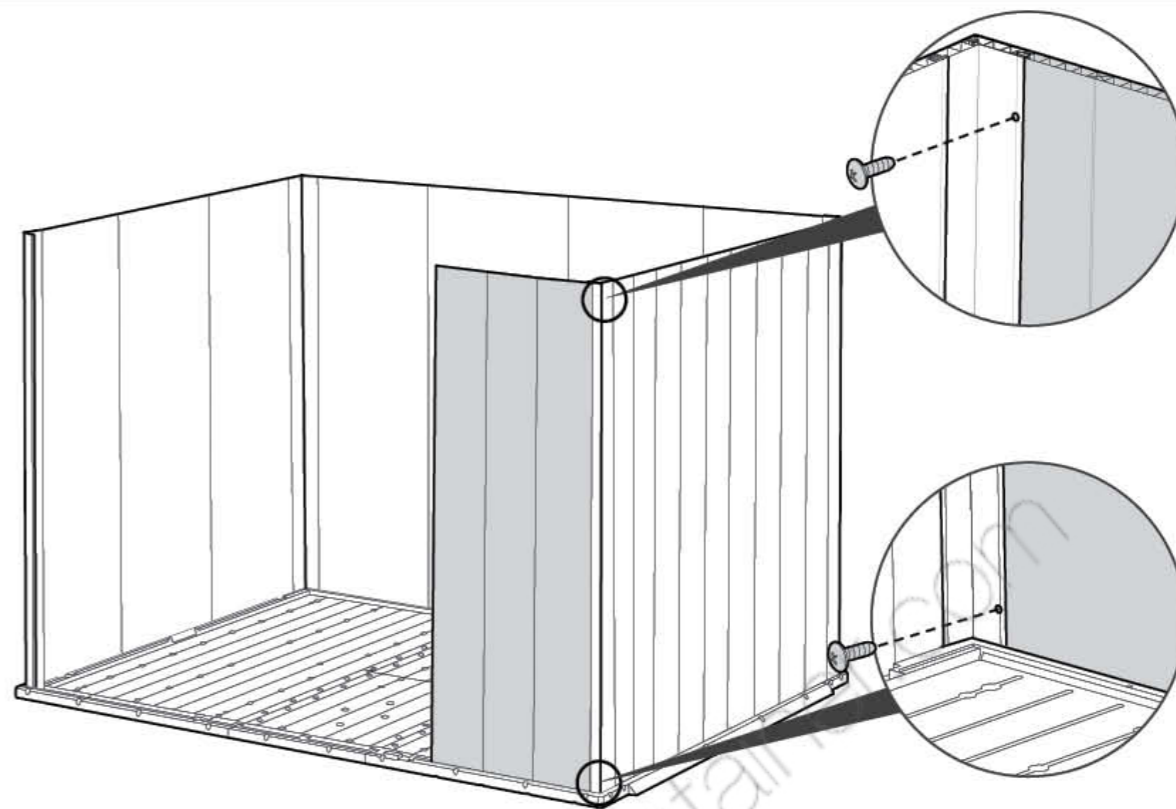

20



nE PF (x2)



KP (x2)

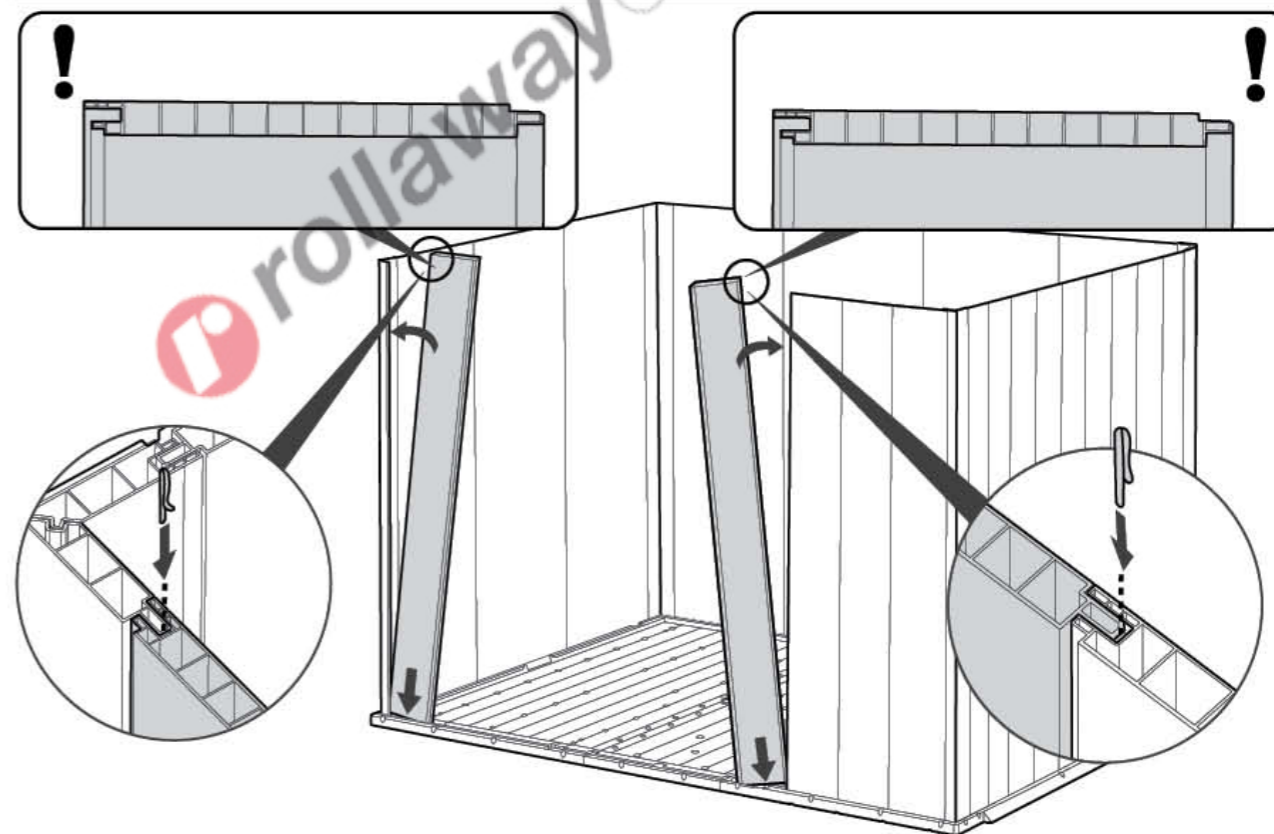

21

⊕ s13b (x4)

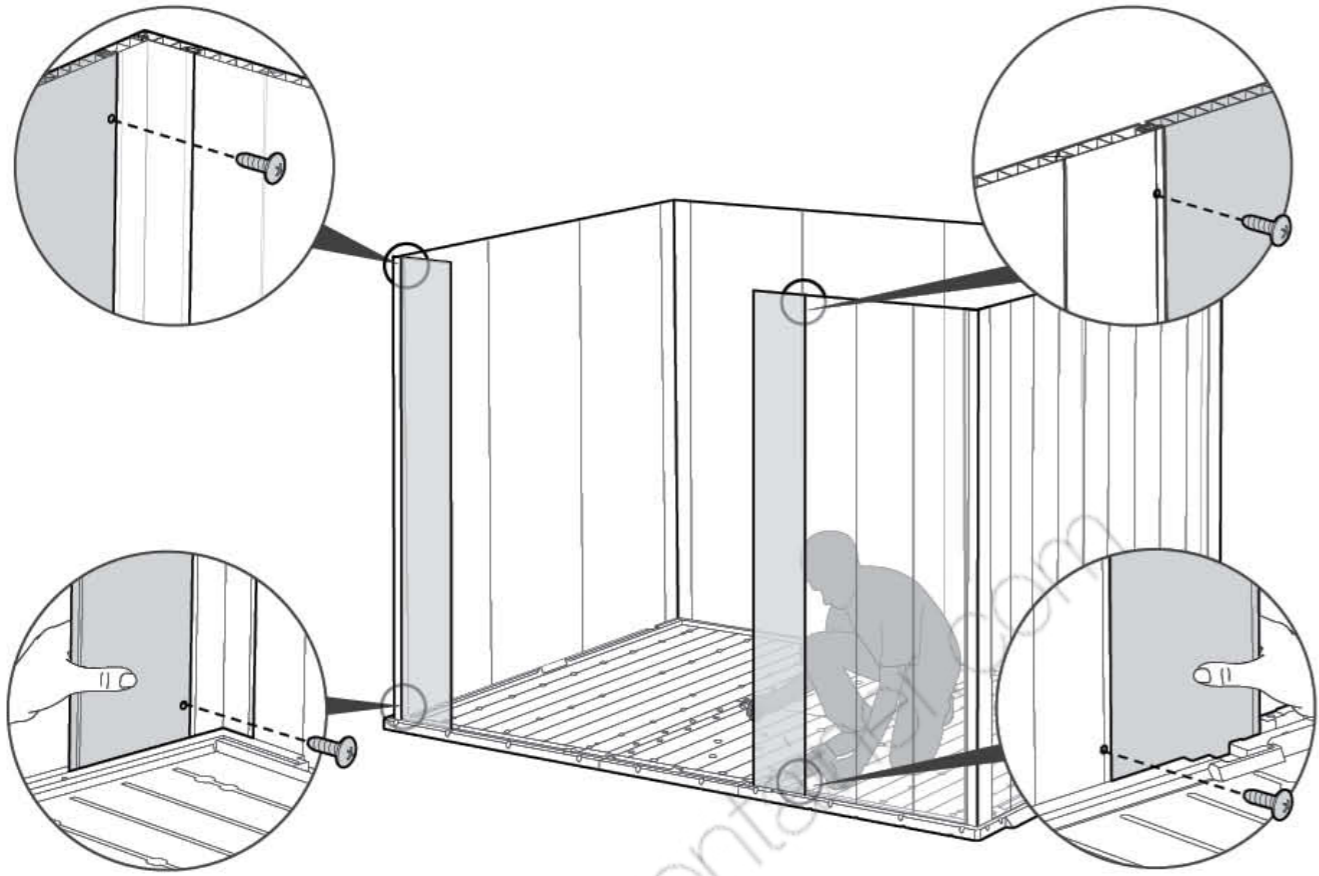

22

⊕ nEDSM (x1)

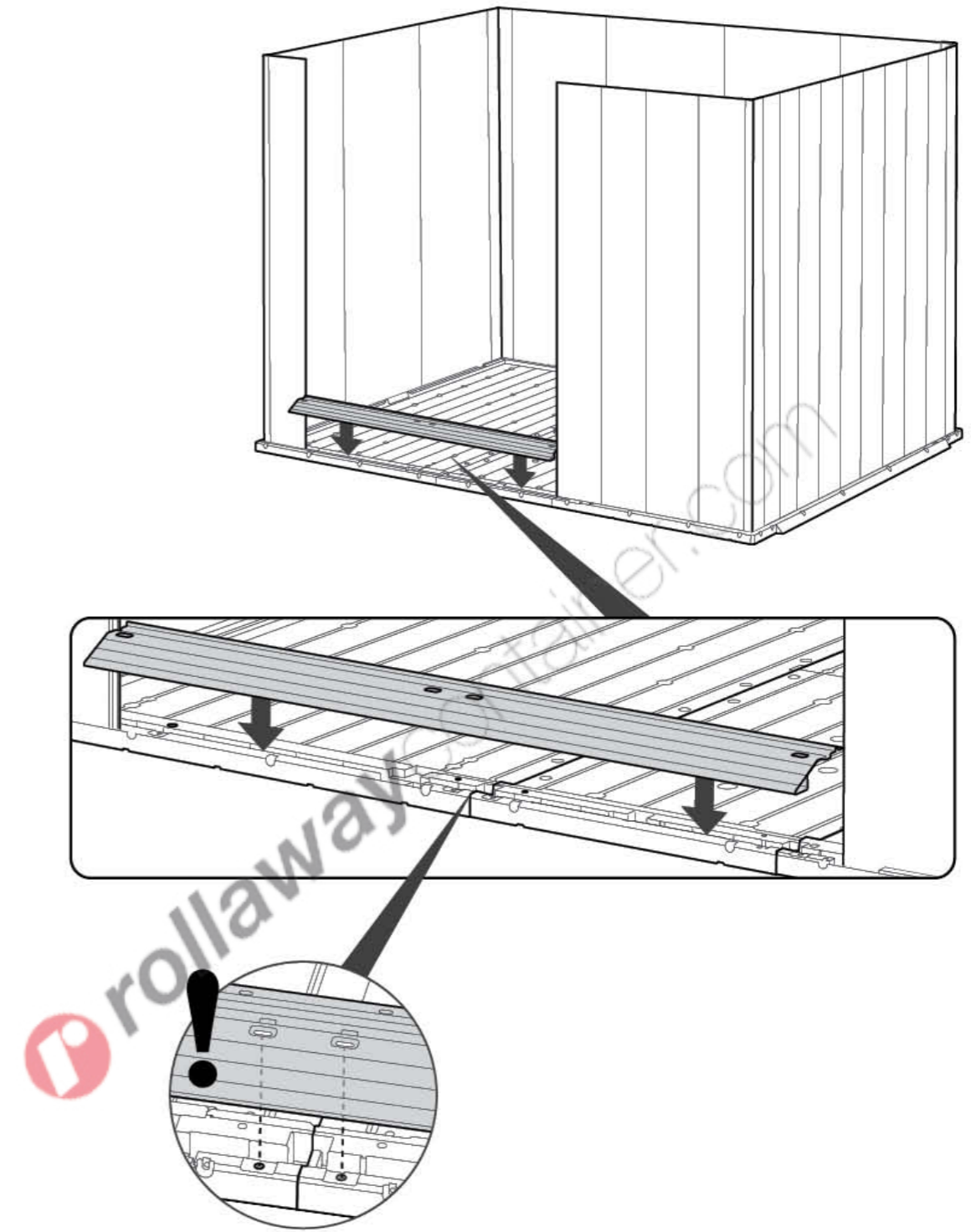

23

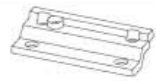

nEDS (x1)



sc15 (x2)

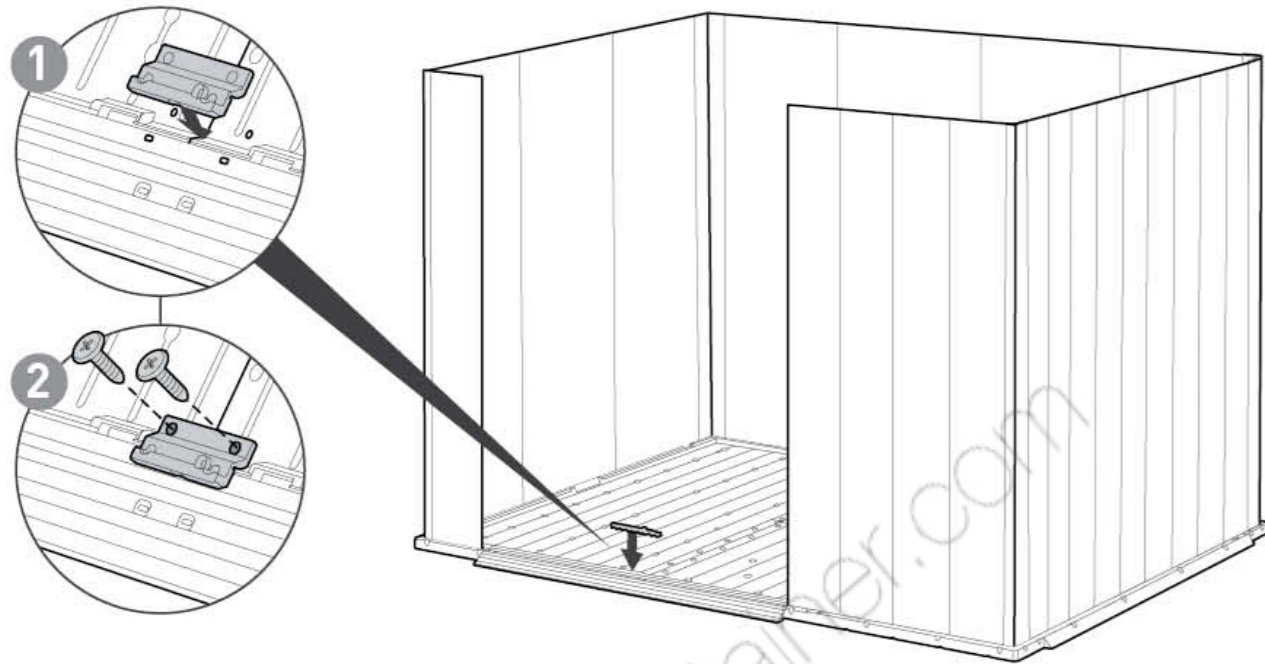

24

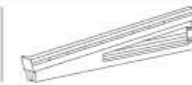

nEBLT (x1)

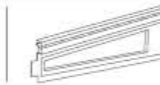

nELT (x1)



sc15 (x3)

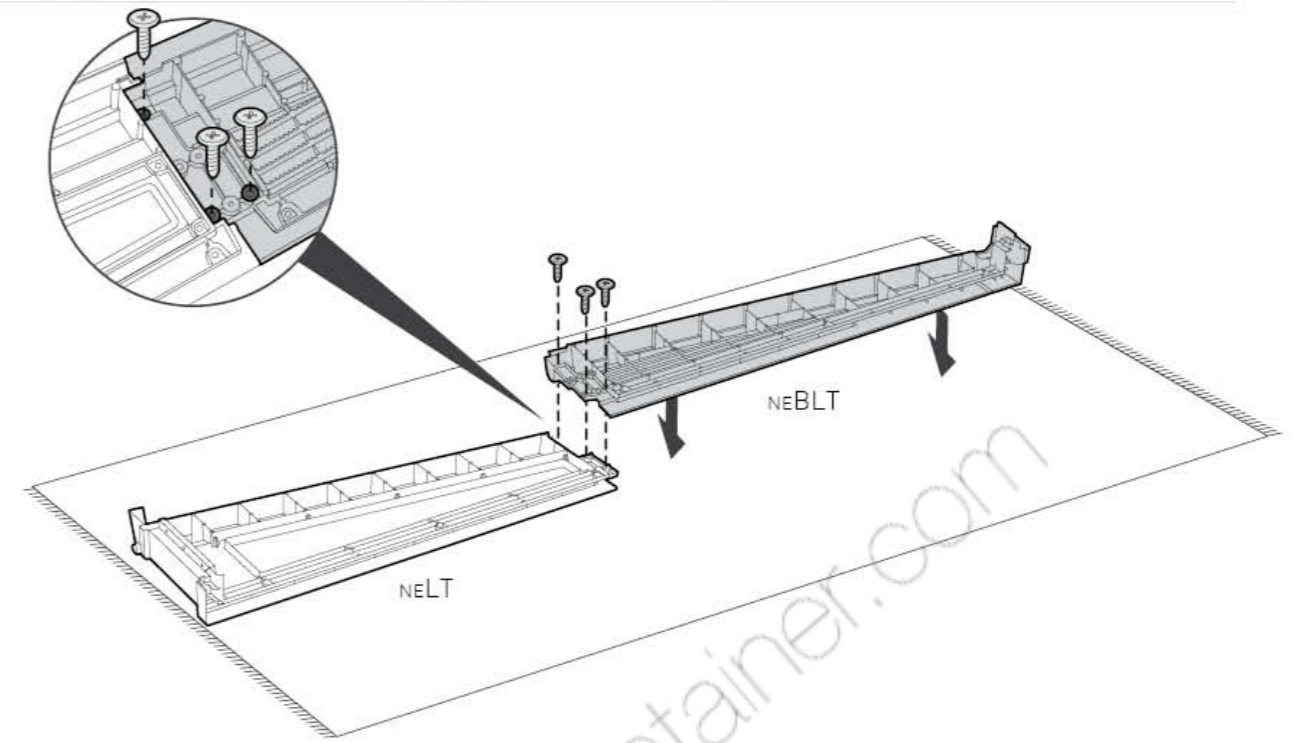

25

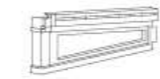

nERT (x1)



nEBRT (x1)



sc15 (x3)

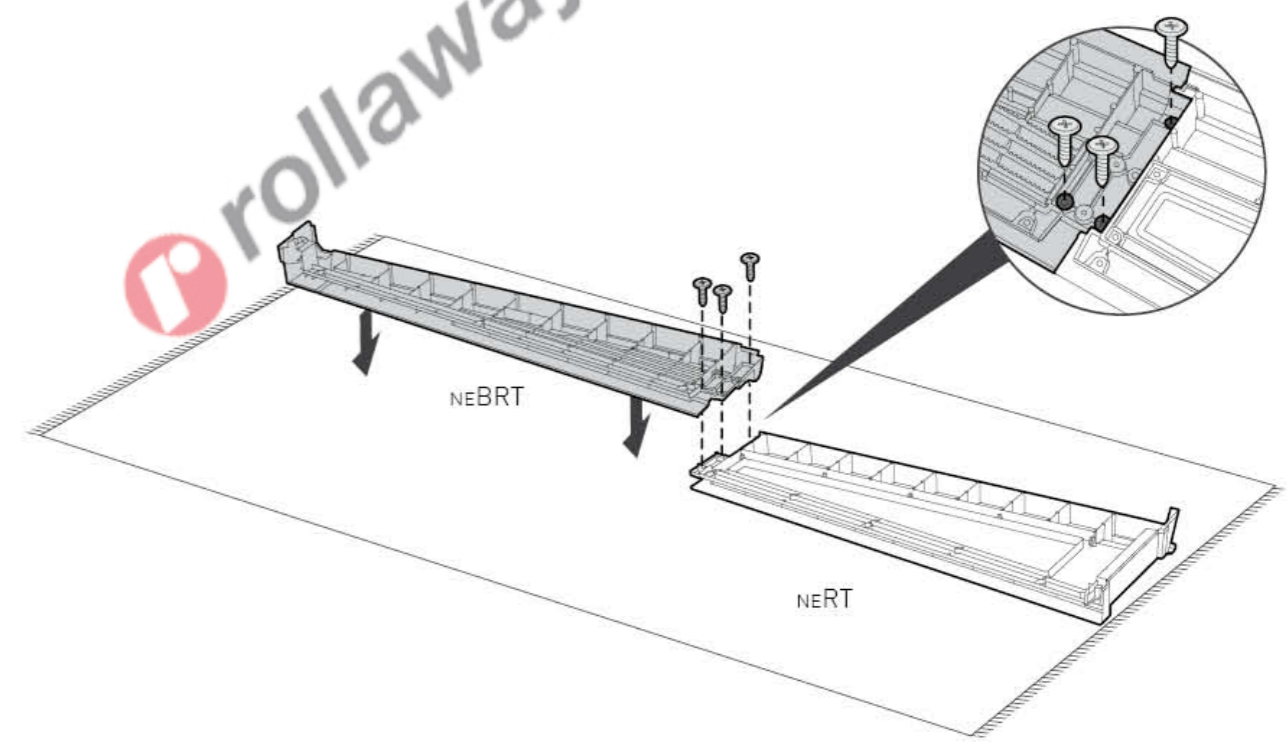

rollawaycontainer.com

rollawaycontainer.com

26

NEGT (x2)

NEPL

Right
Droit
Derecho
Richtig
Rechts
Destra
Direito

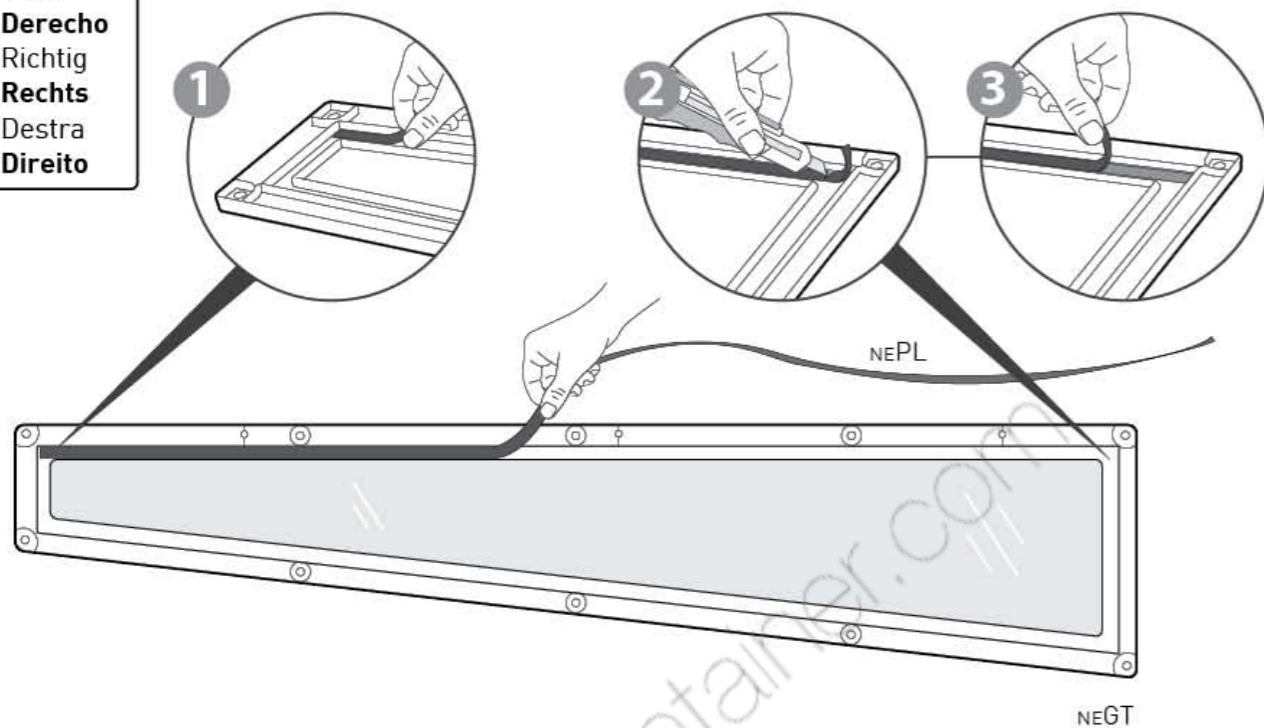

NEGT

27

NEBRT + NERT

NELT + NEBLT

sc15 (x20)

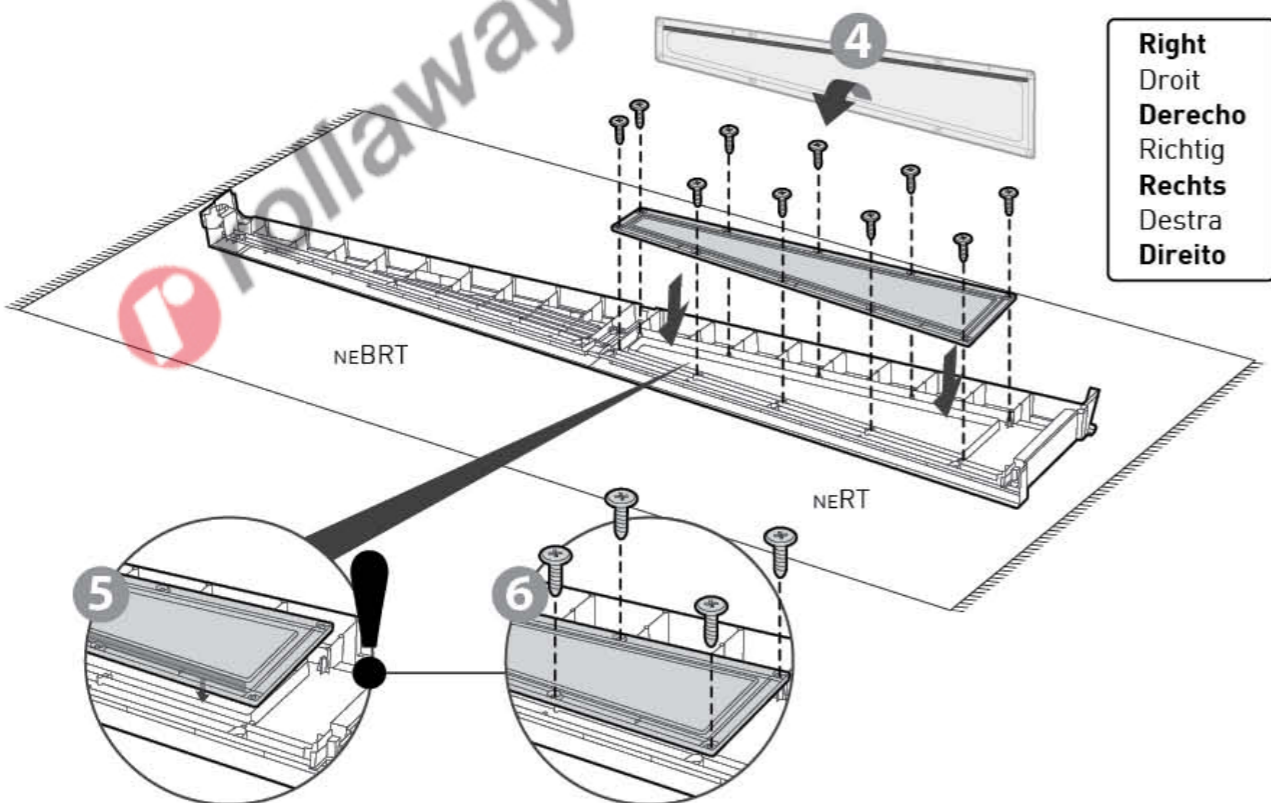

Right
Droit
Derecho
Richtig
Rechts
Destra
Direito

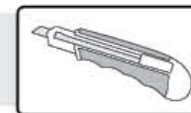

Left
Gauche
Izquierdo
Verließ
Links
Sinistra
esquermo

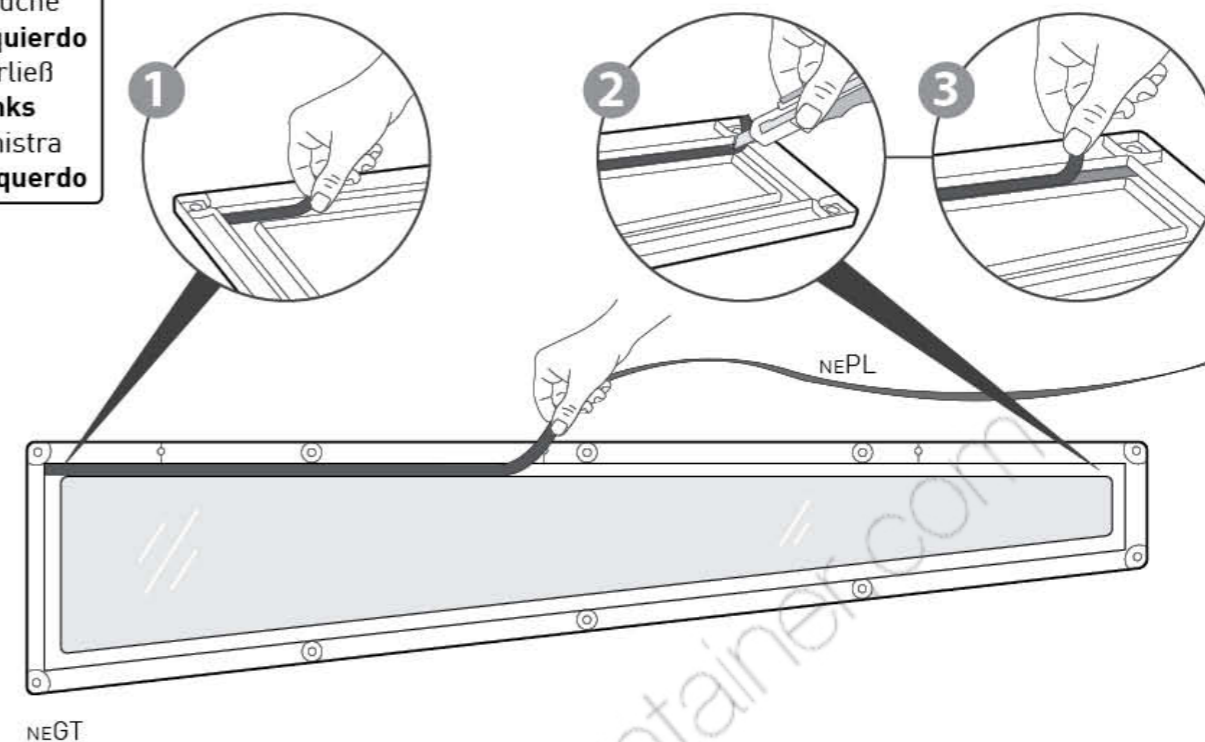

NEGT

Left
Gauche
Izquierdo
Verließ
Links
Sinistra
esquermo

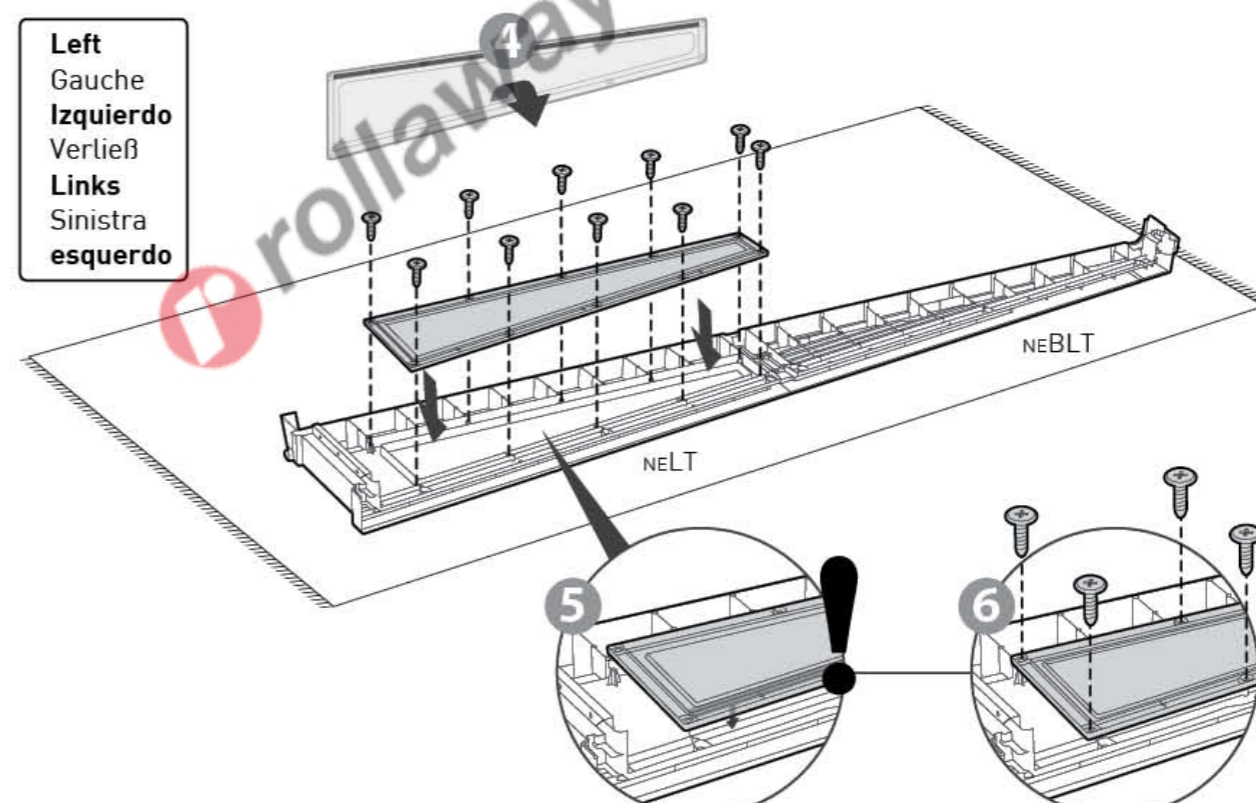

28   NEFFM (x1)  NEFF (x1)  sc15 (x2)

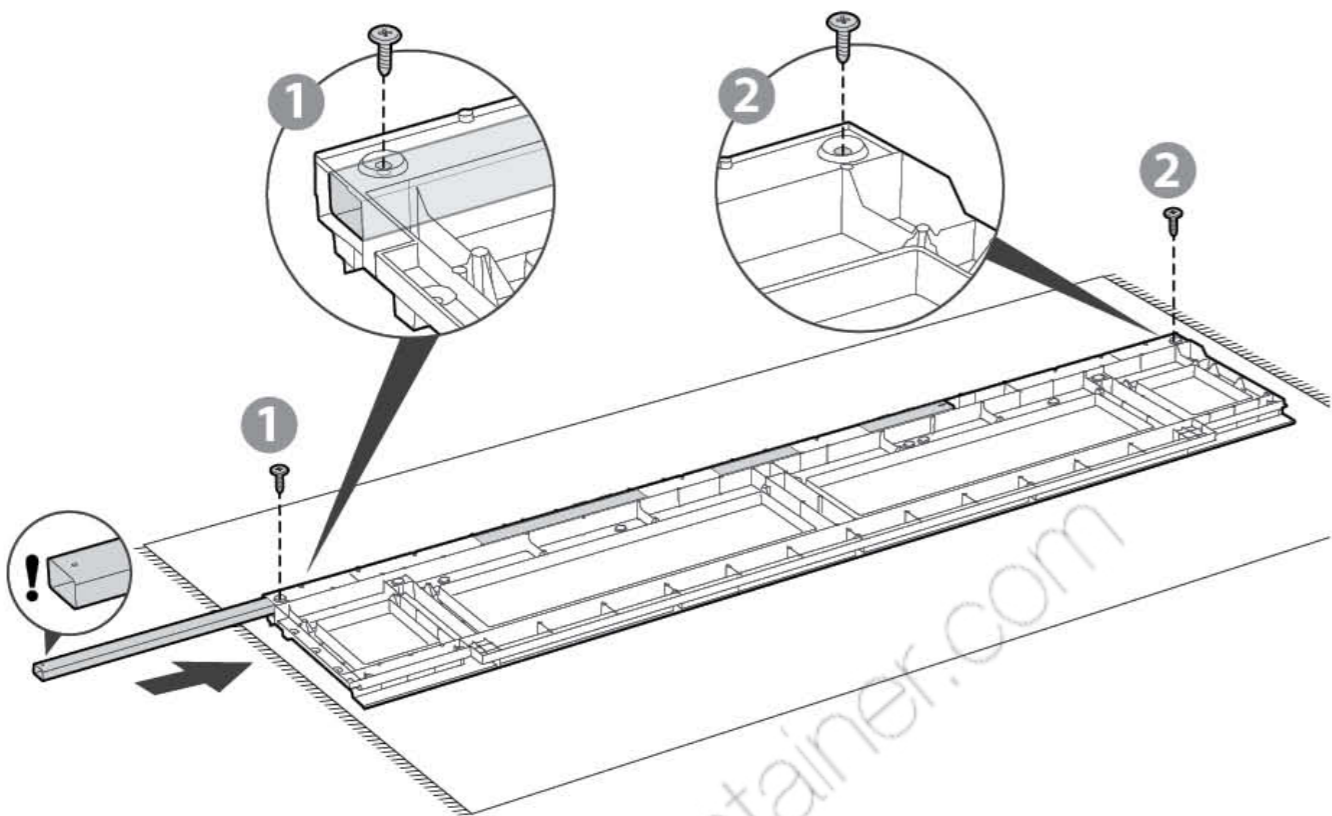

29   NETDP (x1)  sc15 (x3)

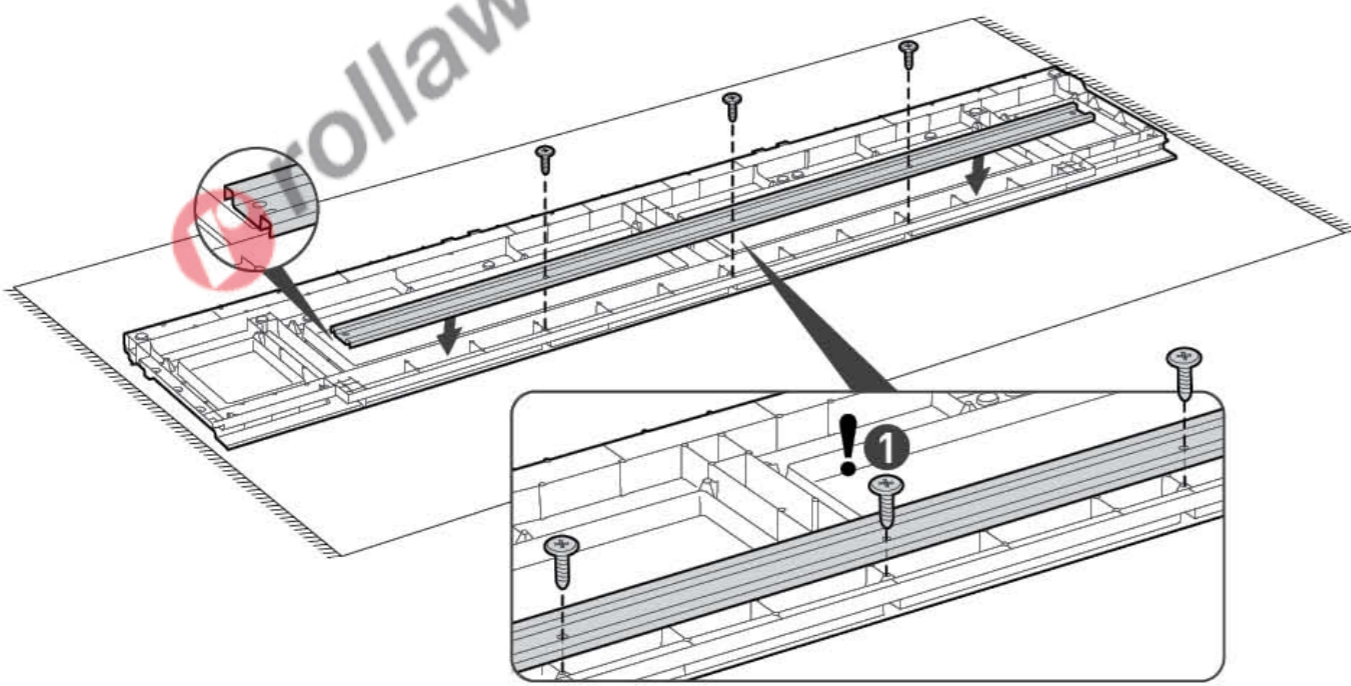

30  NEGR (x2)  NEPL  sc15 (x24) 

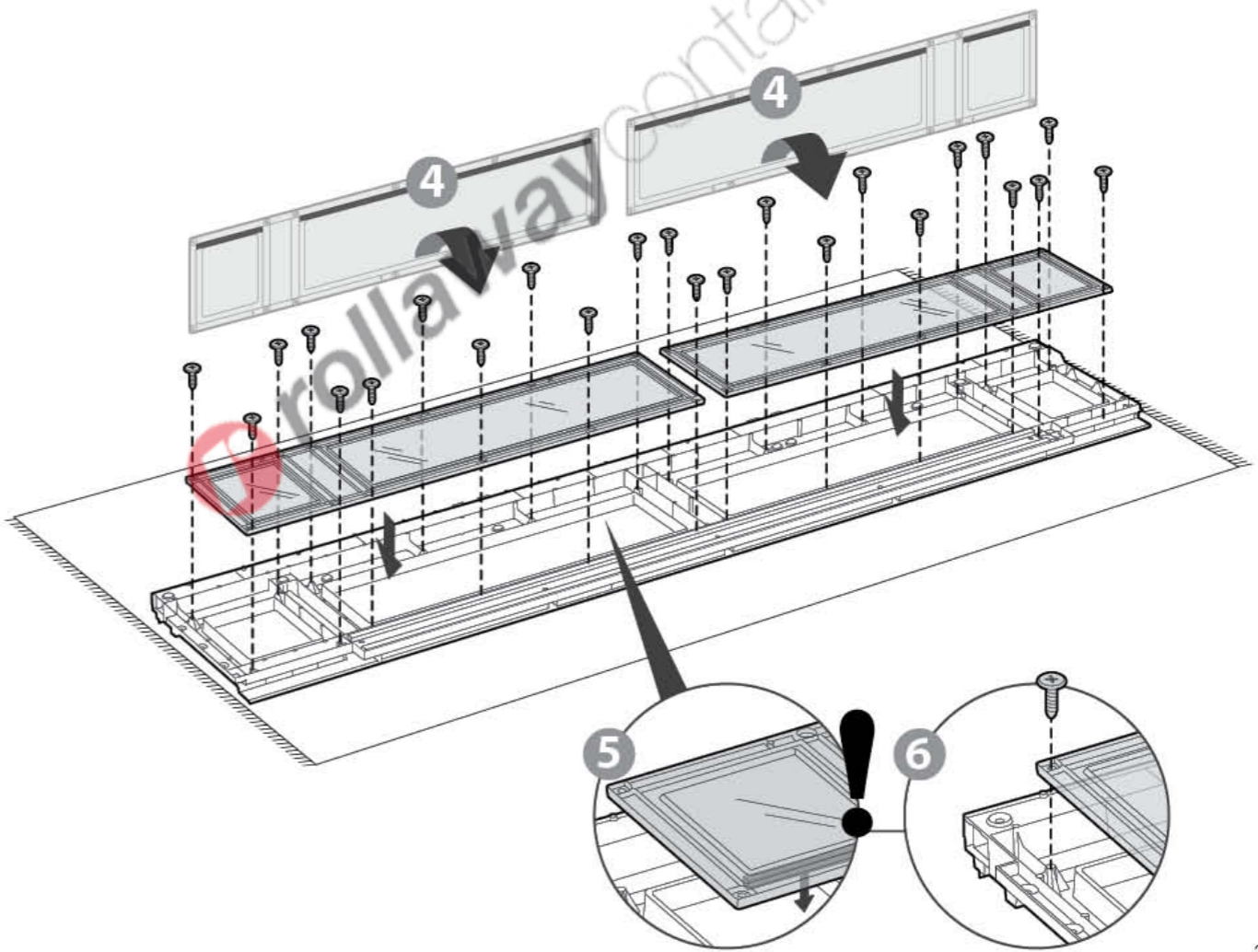
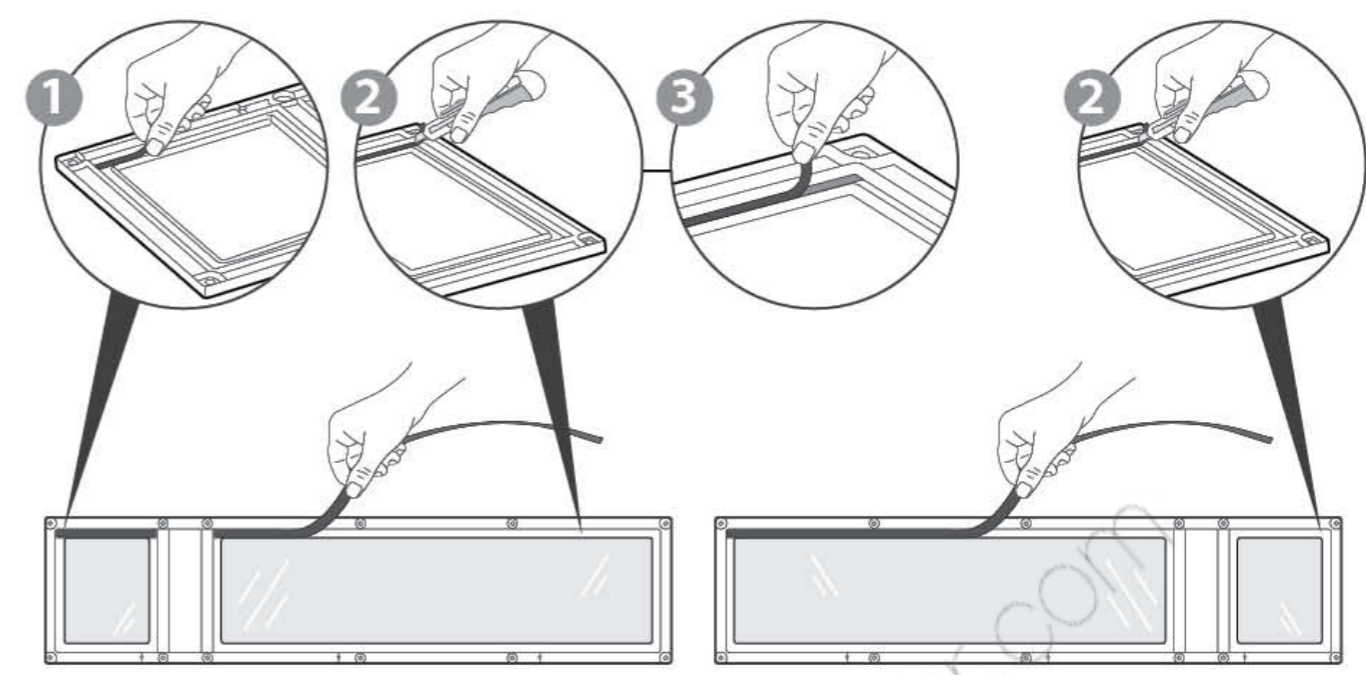

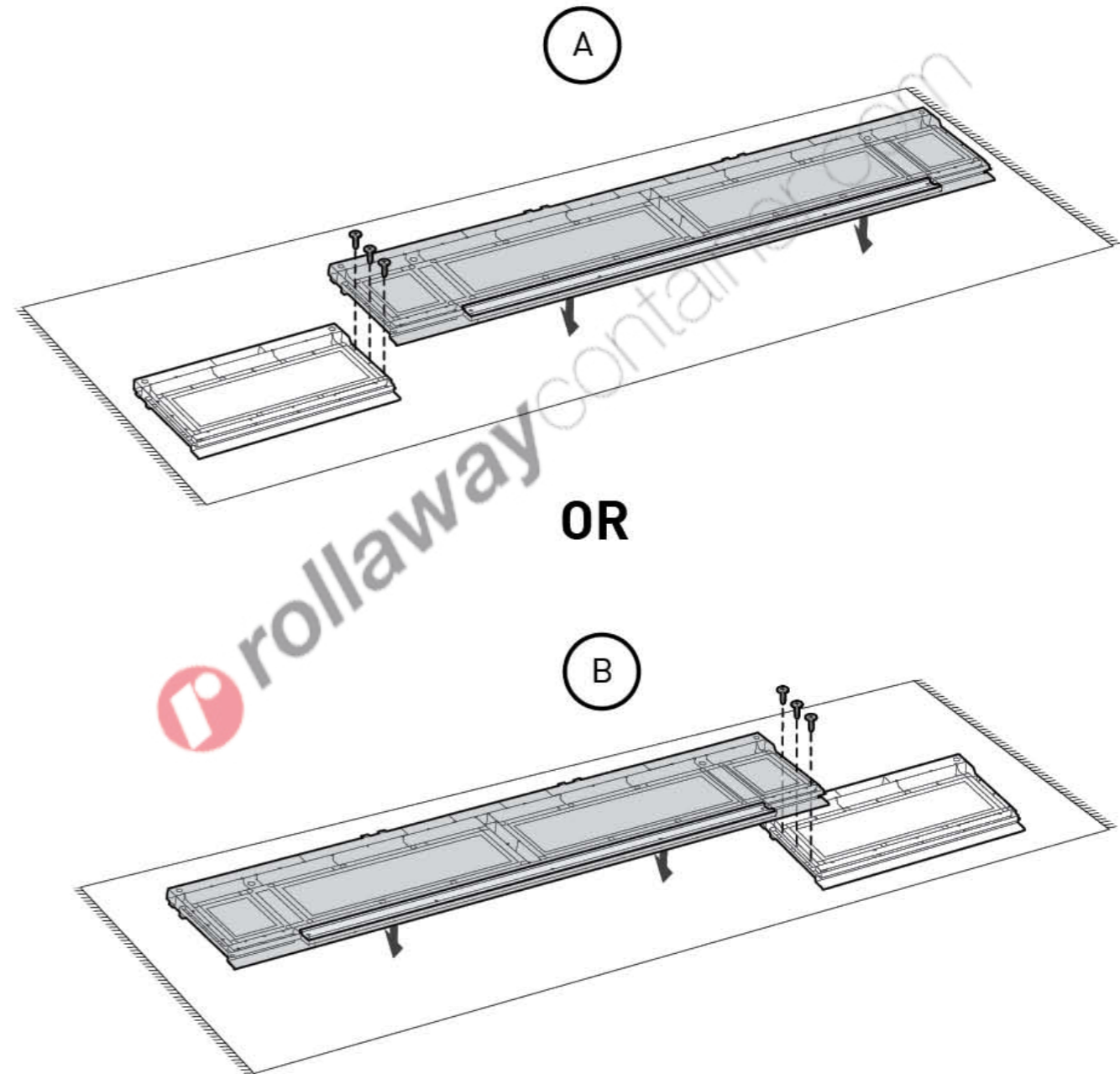
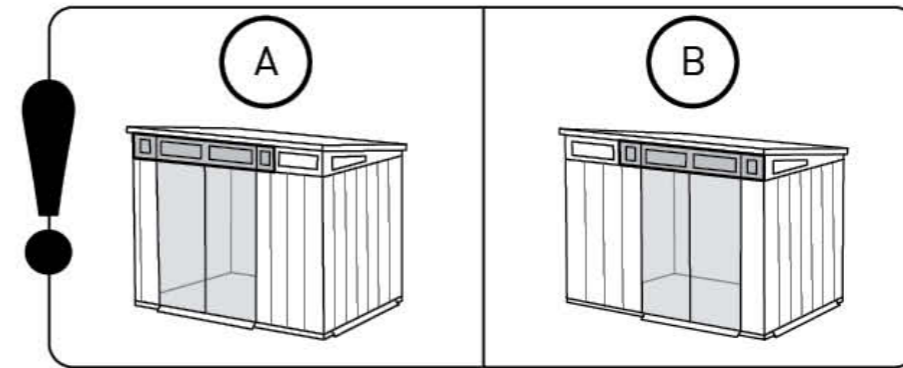
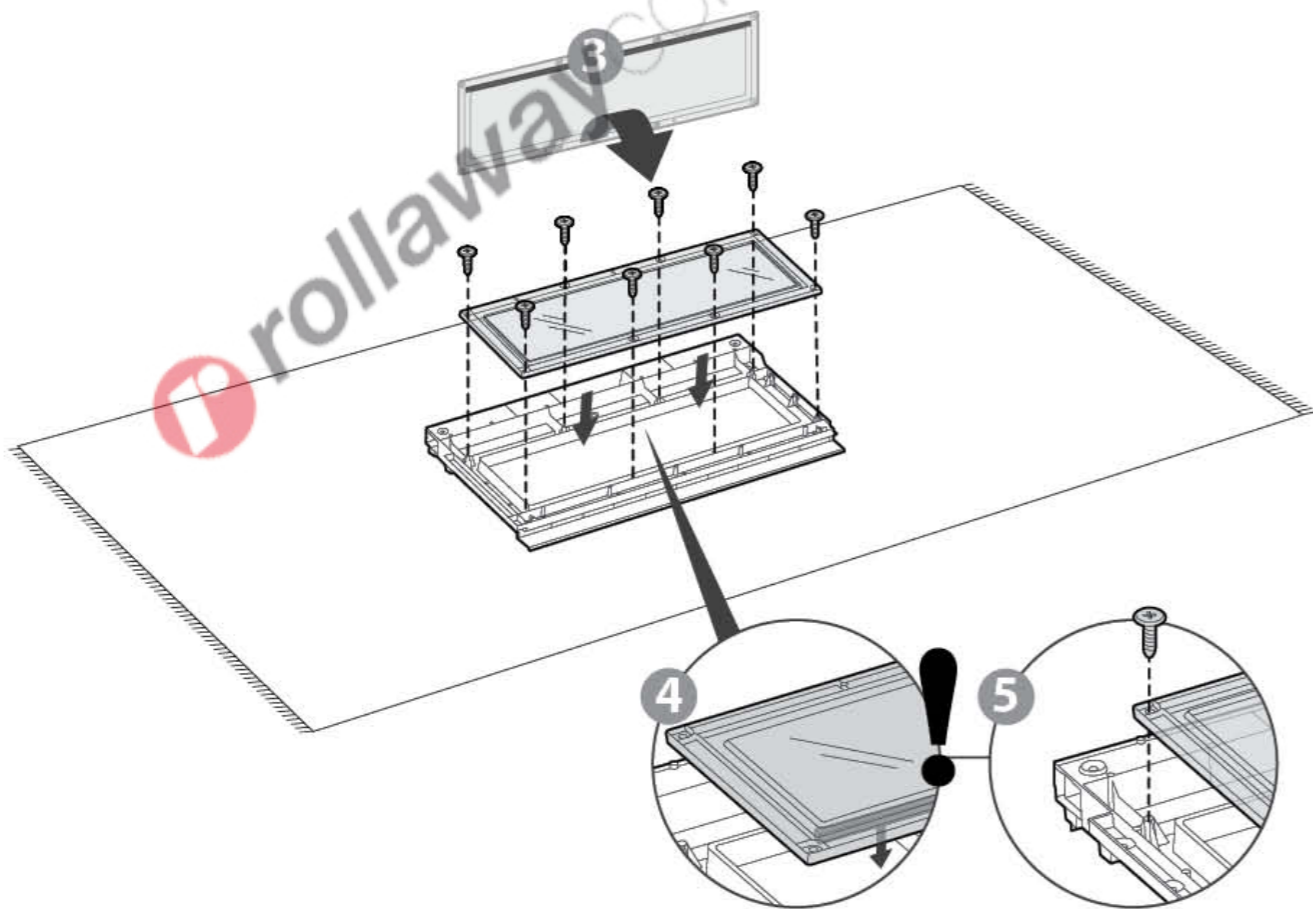
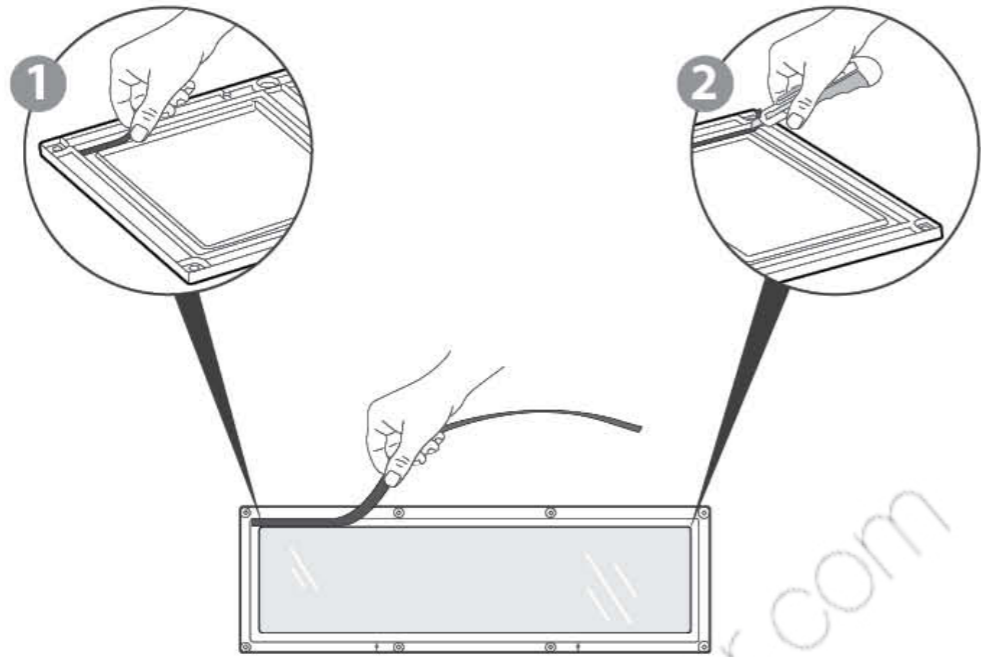

33



nEMRC (x1)



sc15 (x2)

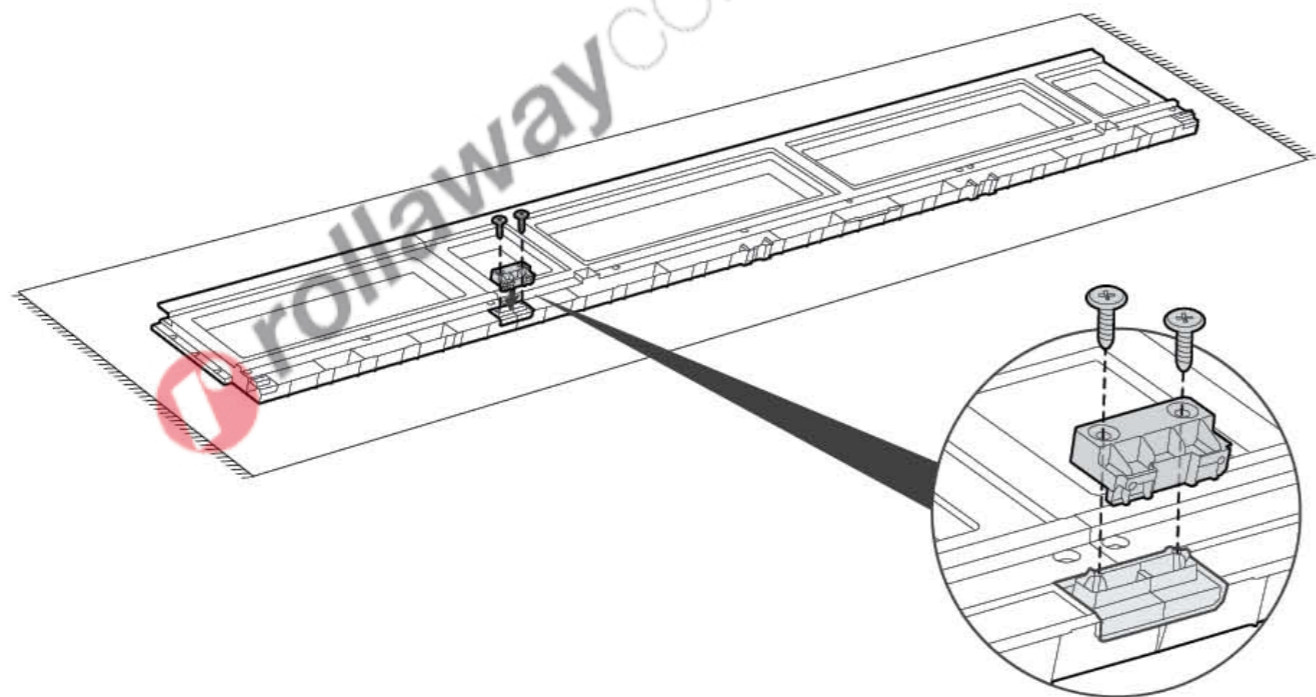
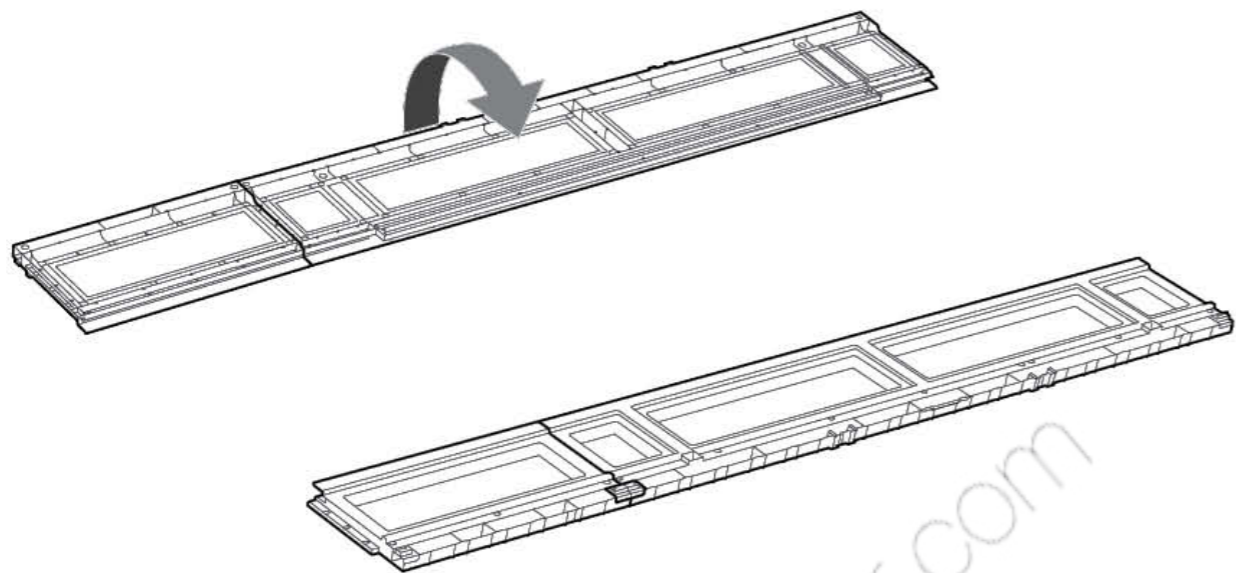

34

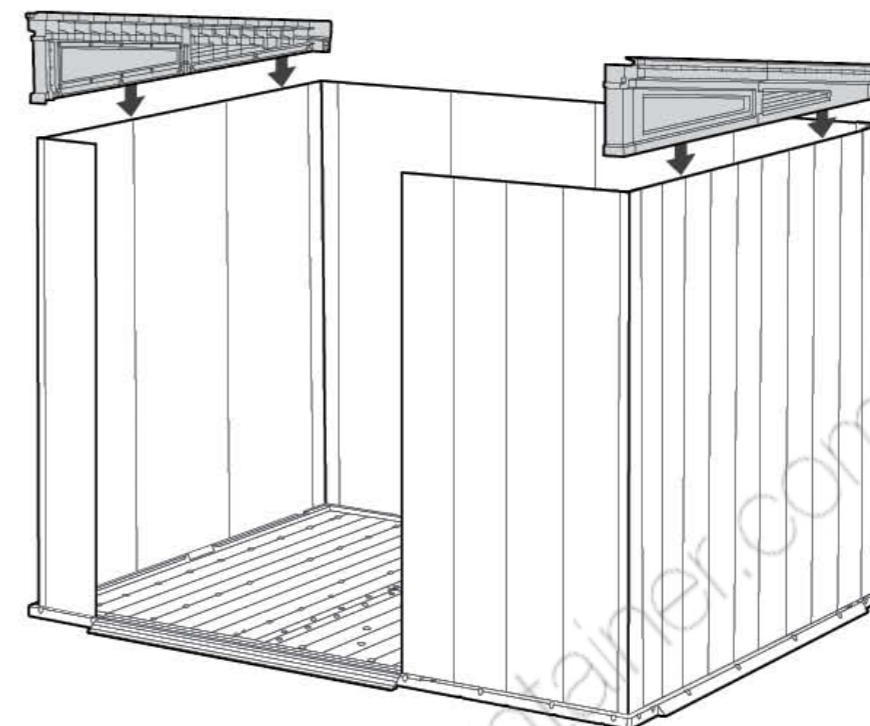
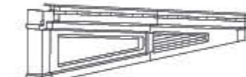

35

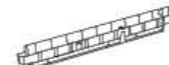

nELD (x1)



nERD (x1)



nEDE (x1)



sc15 (x6)

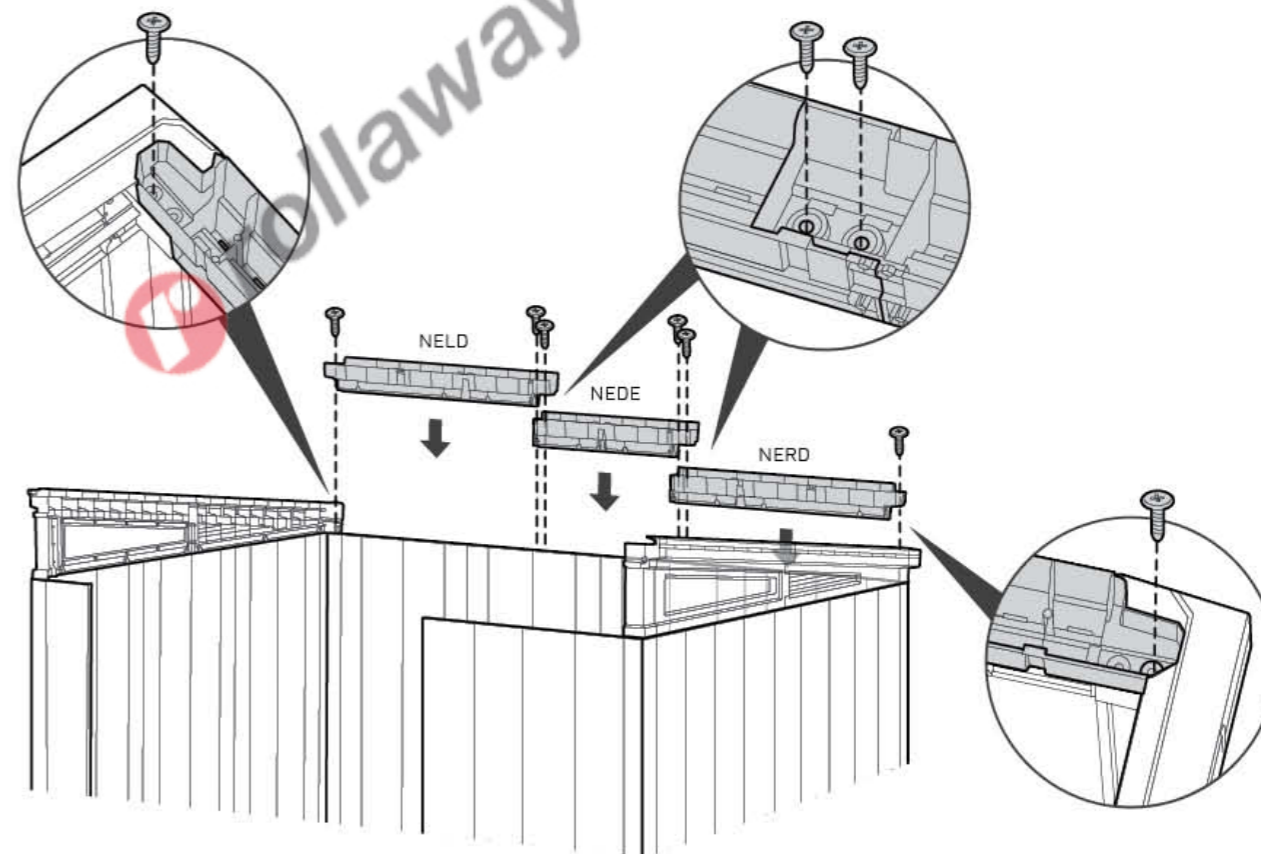

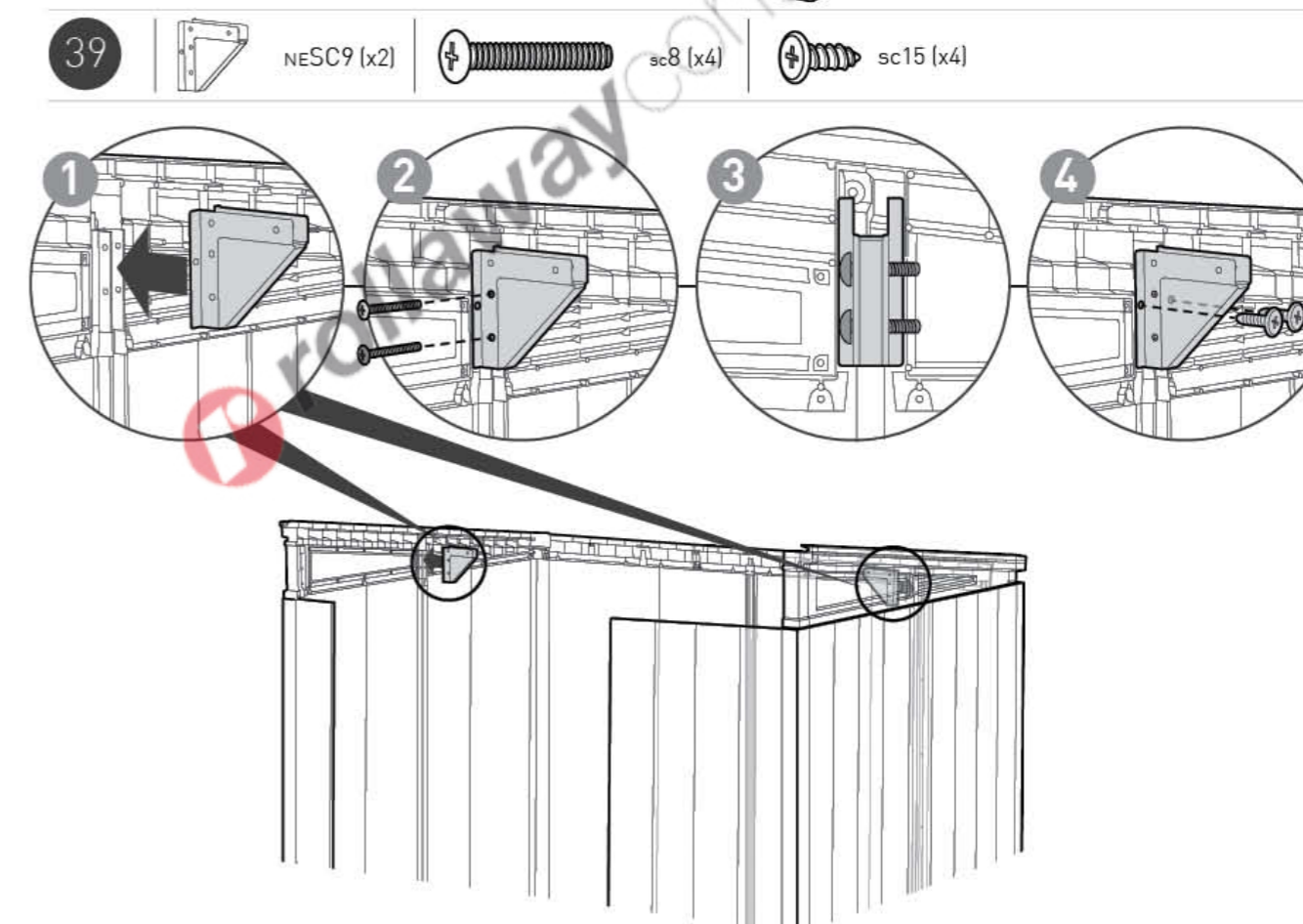
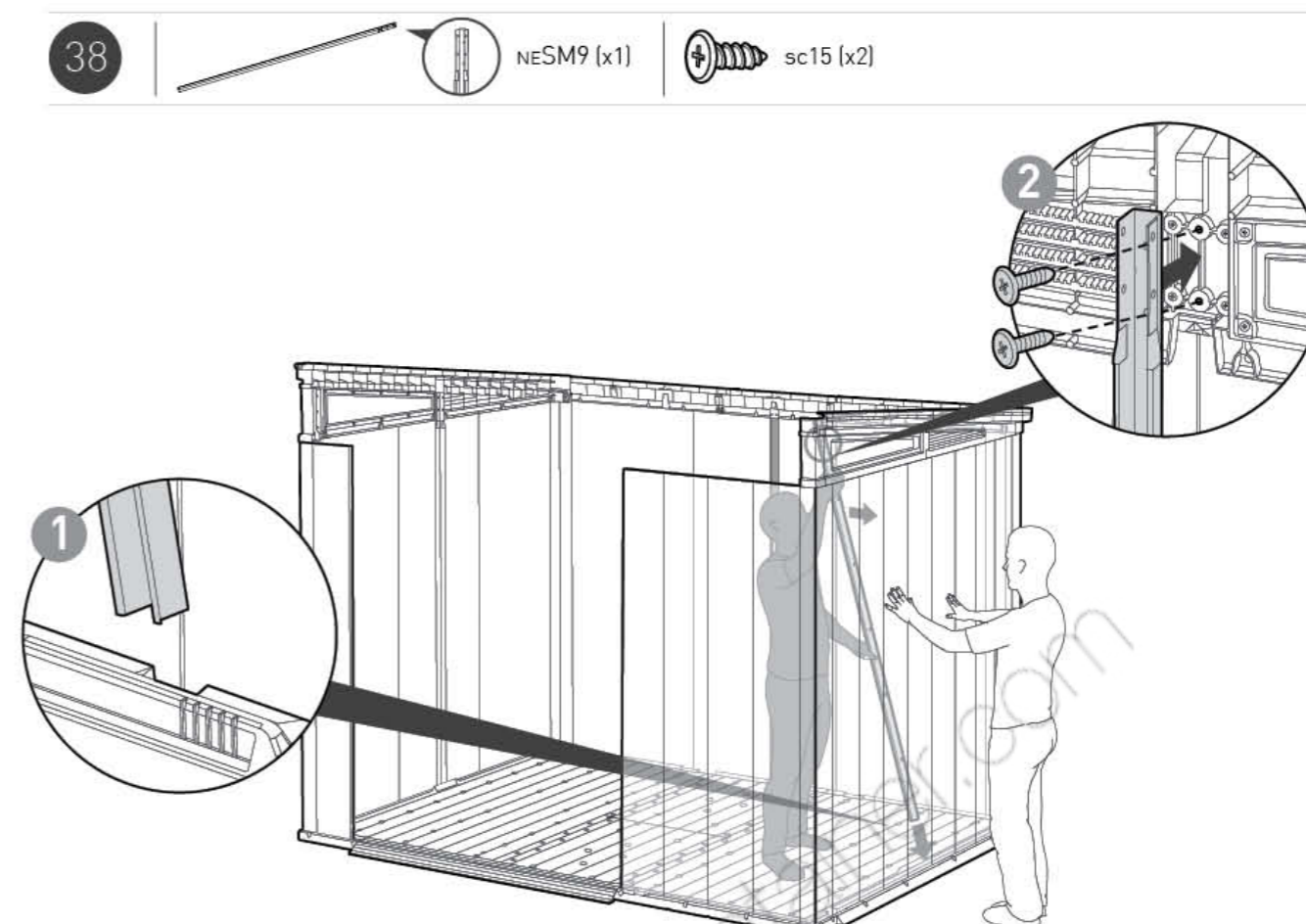
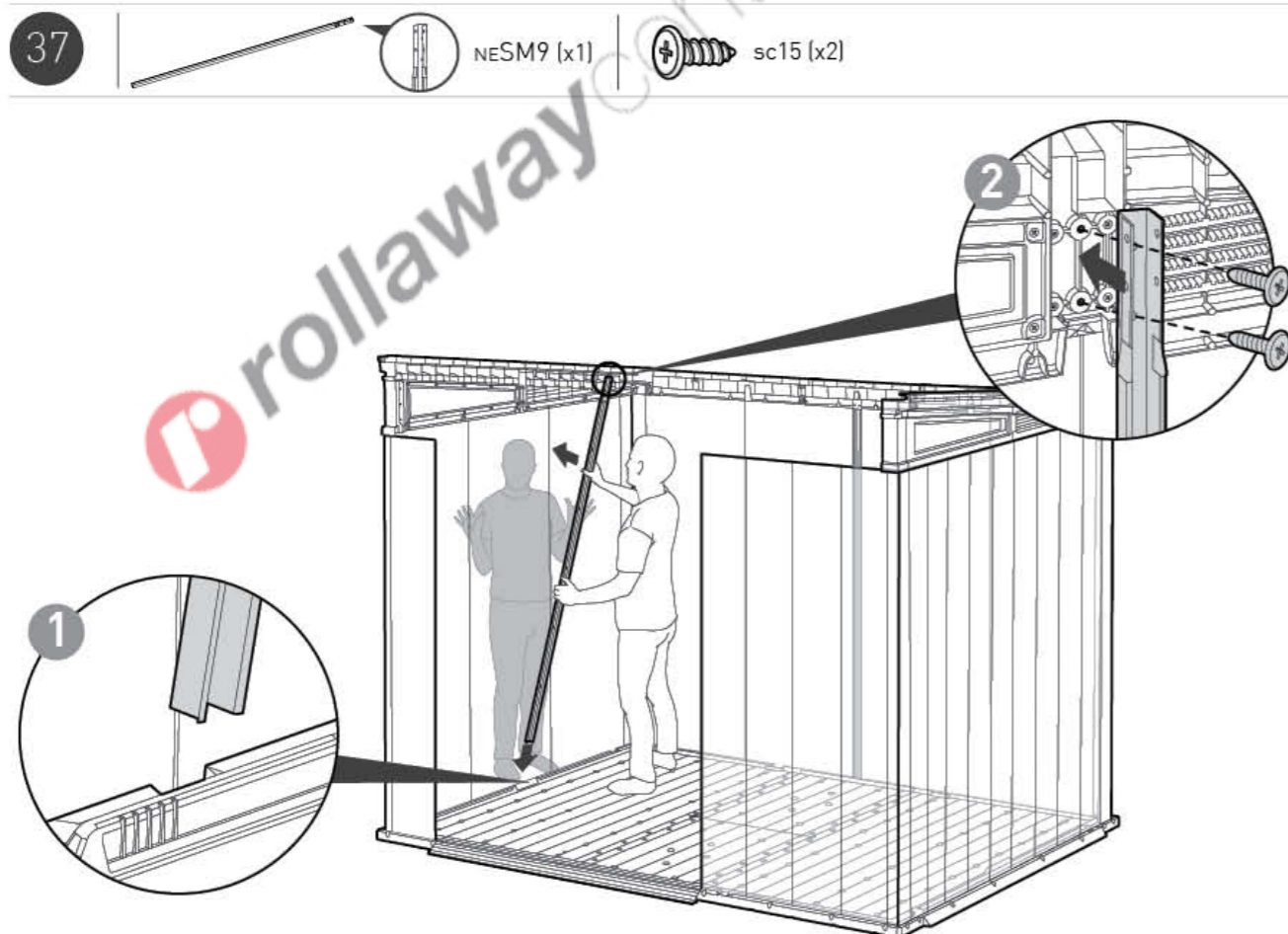
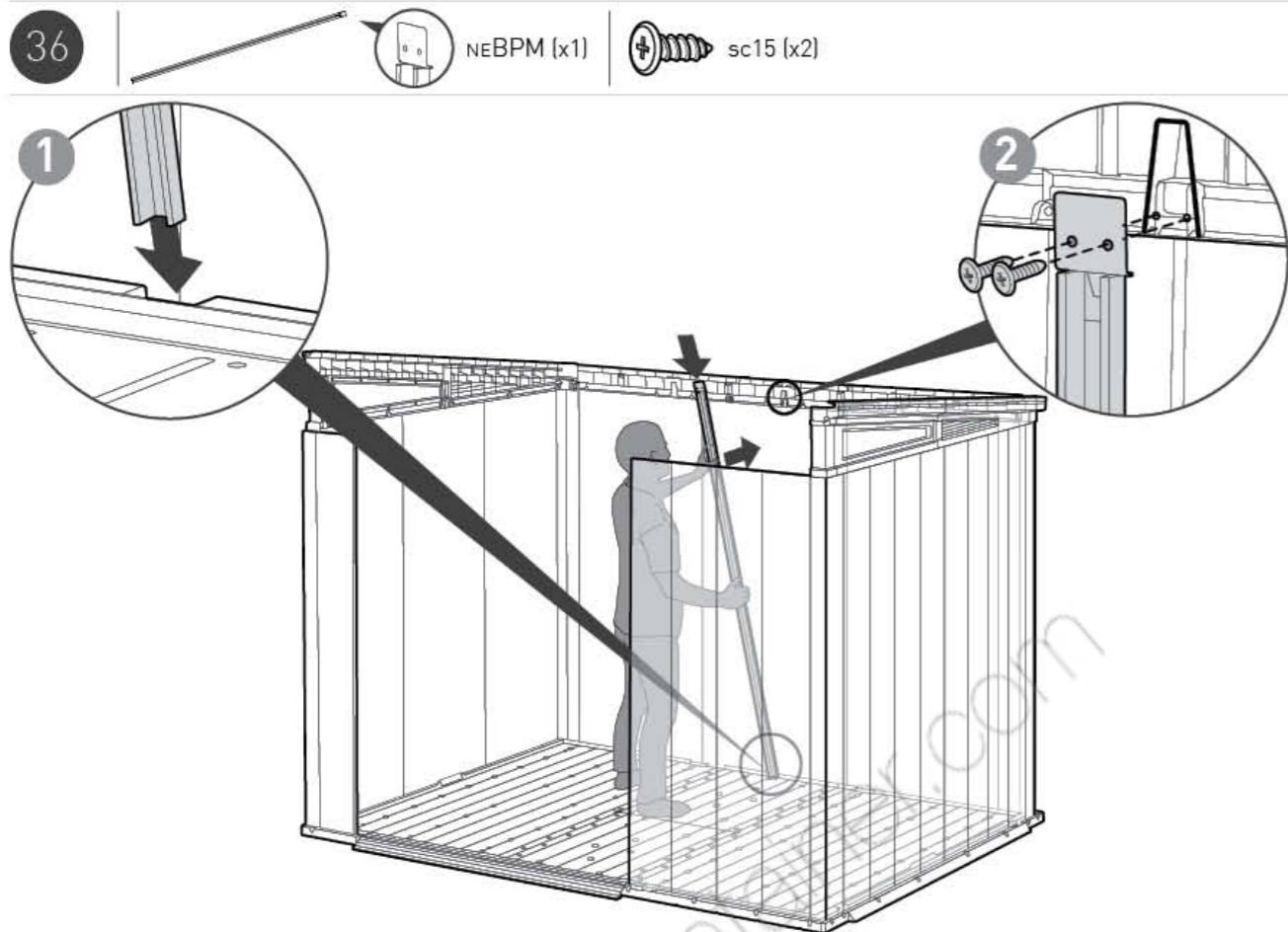

40

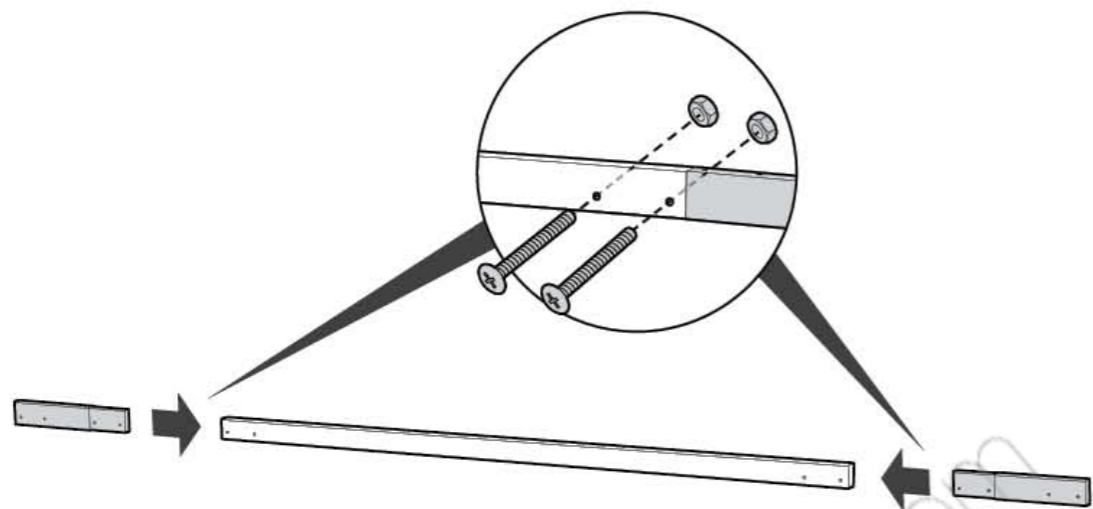

41

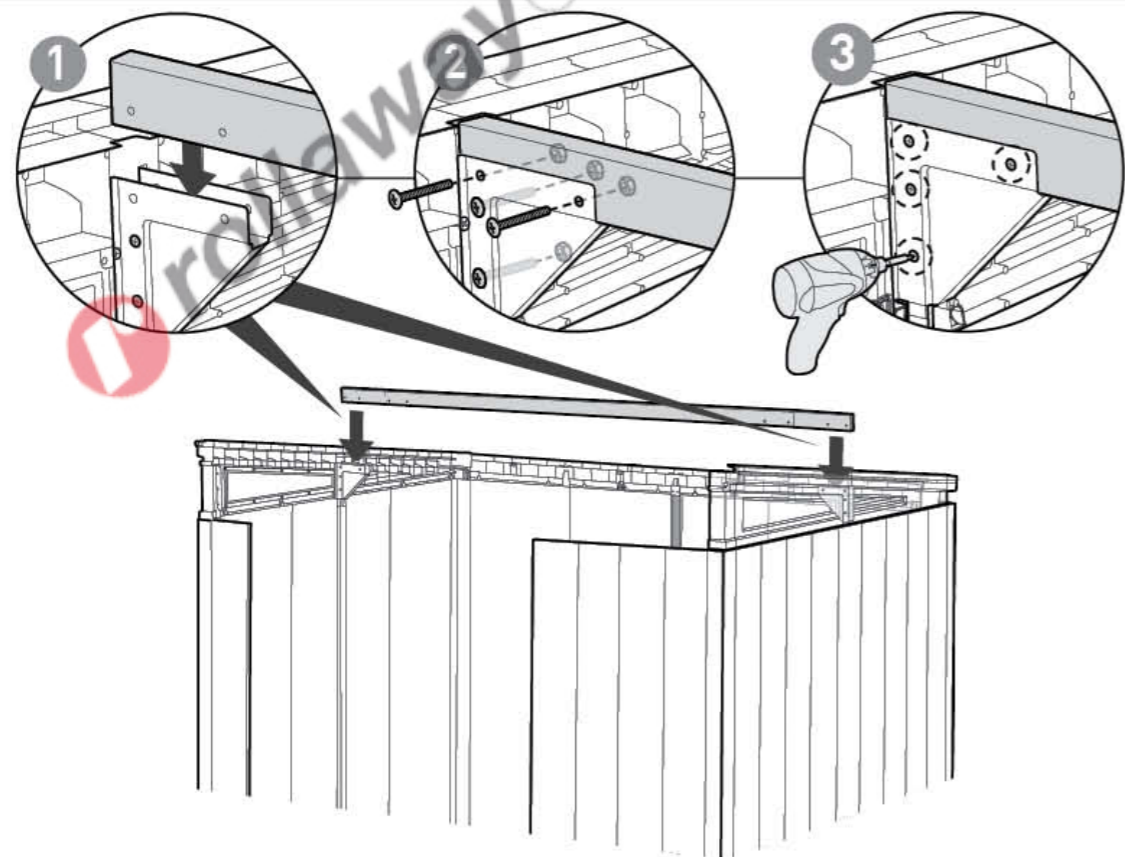
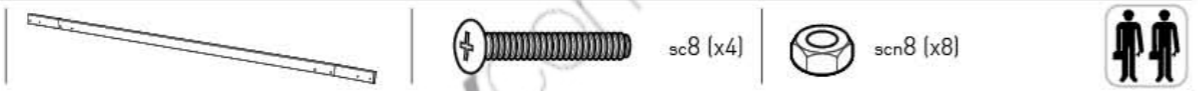

42

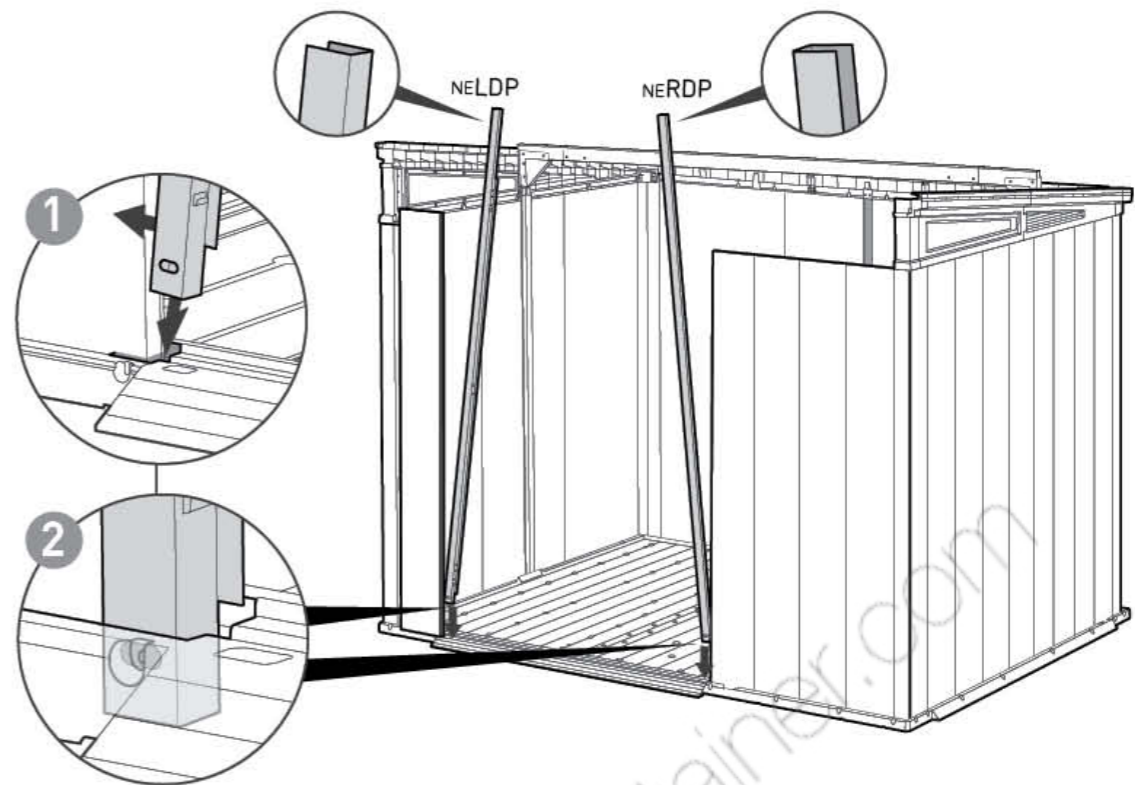
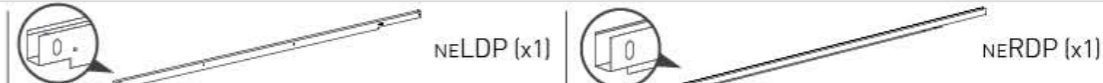

43

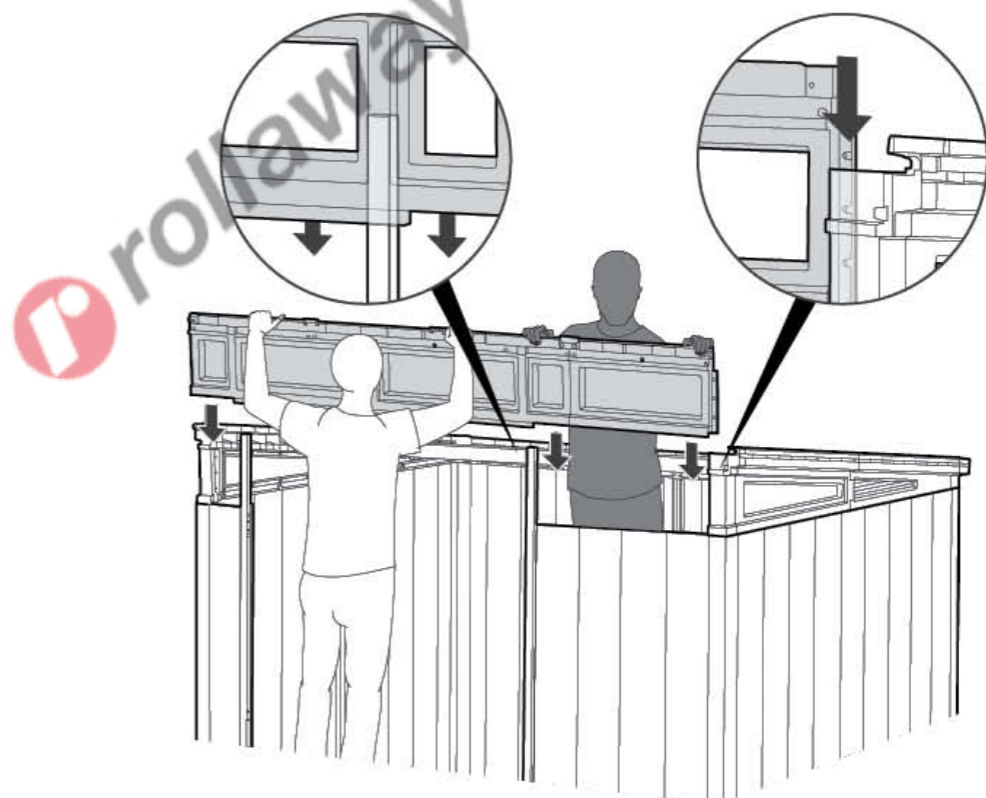

44

sc15 (x8)

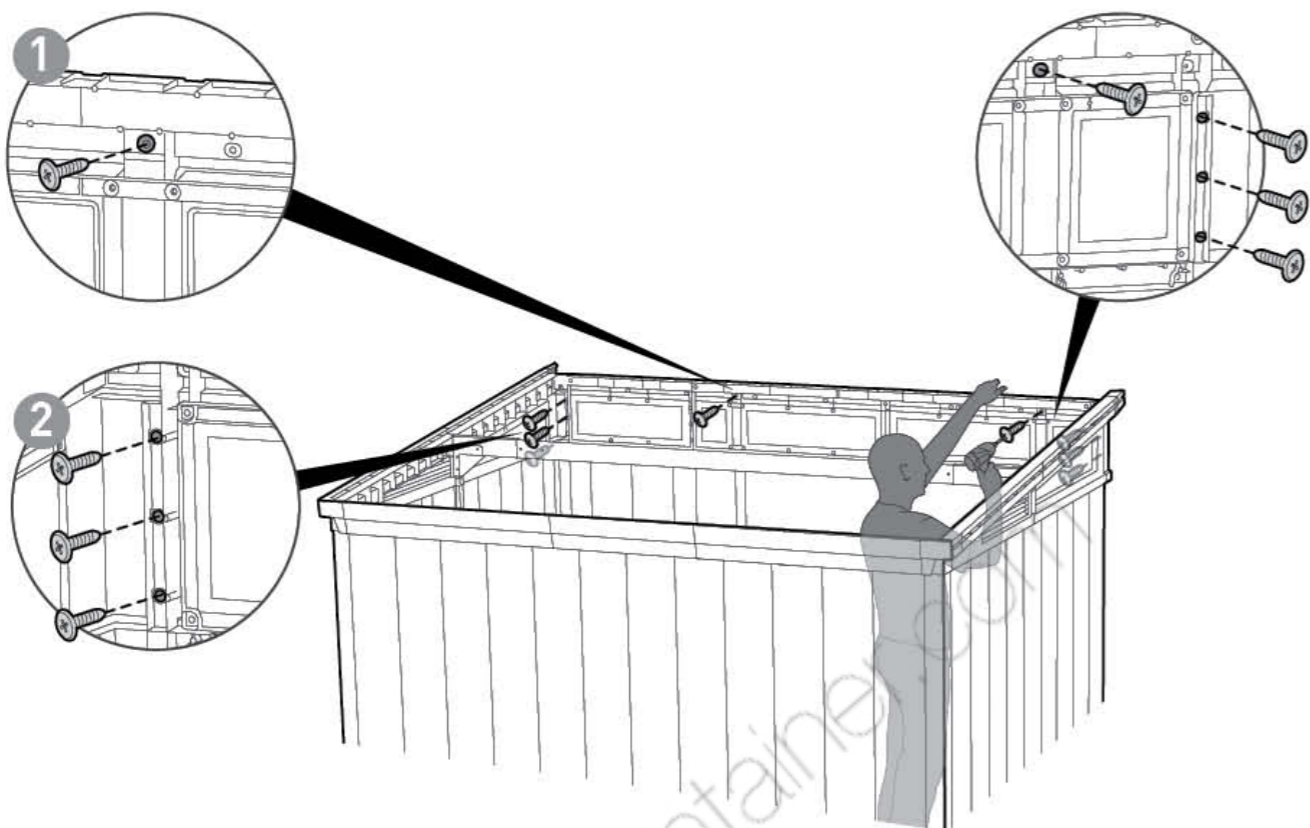

45

NEERA (x3)

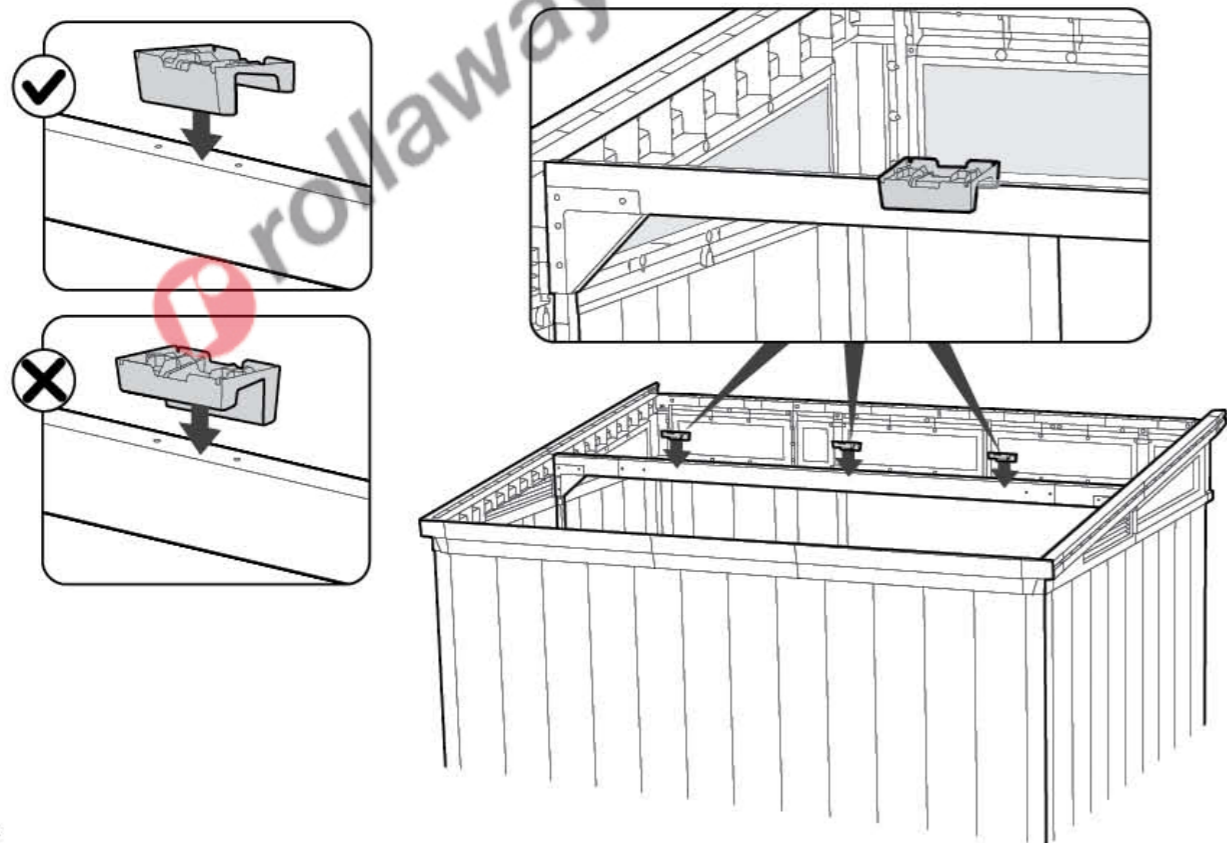

ROOF ASSEMBLY | MONTAGE DU TOIT | ARMADO DEL TECHO | DACHMONTAGE | DAKMONTAGE |
MONTAGGIO DEL TETTO | MONTAGEM DO TELHADO

46

NERM (x3) sc15 (x18)

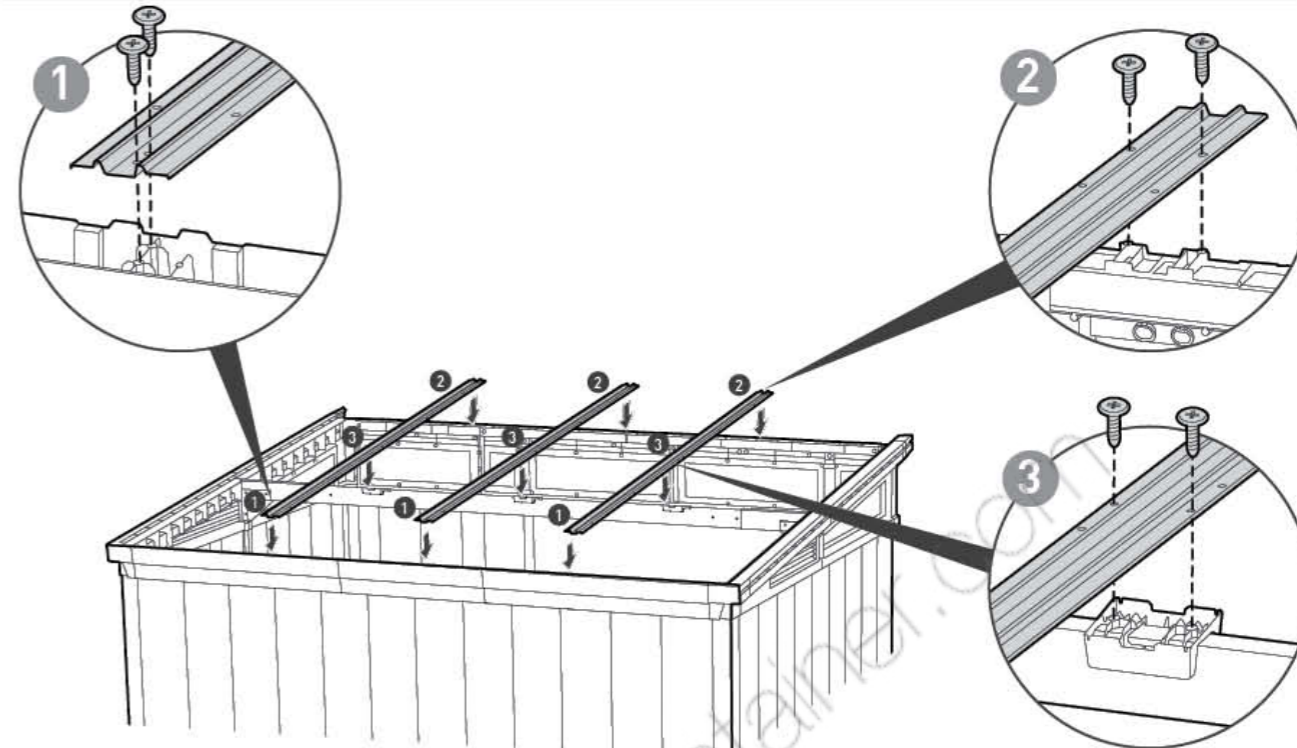

47

NEPRE (x2)

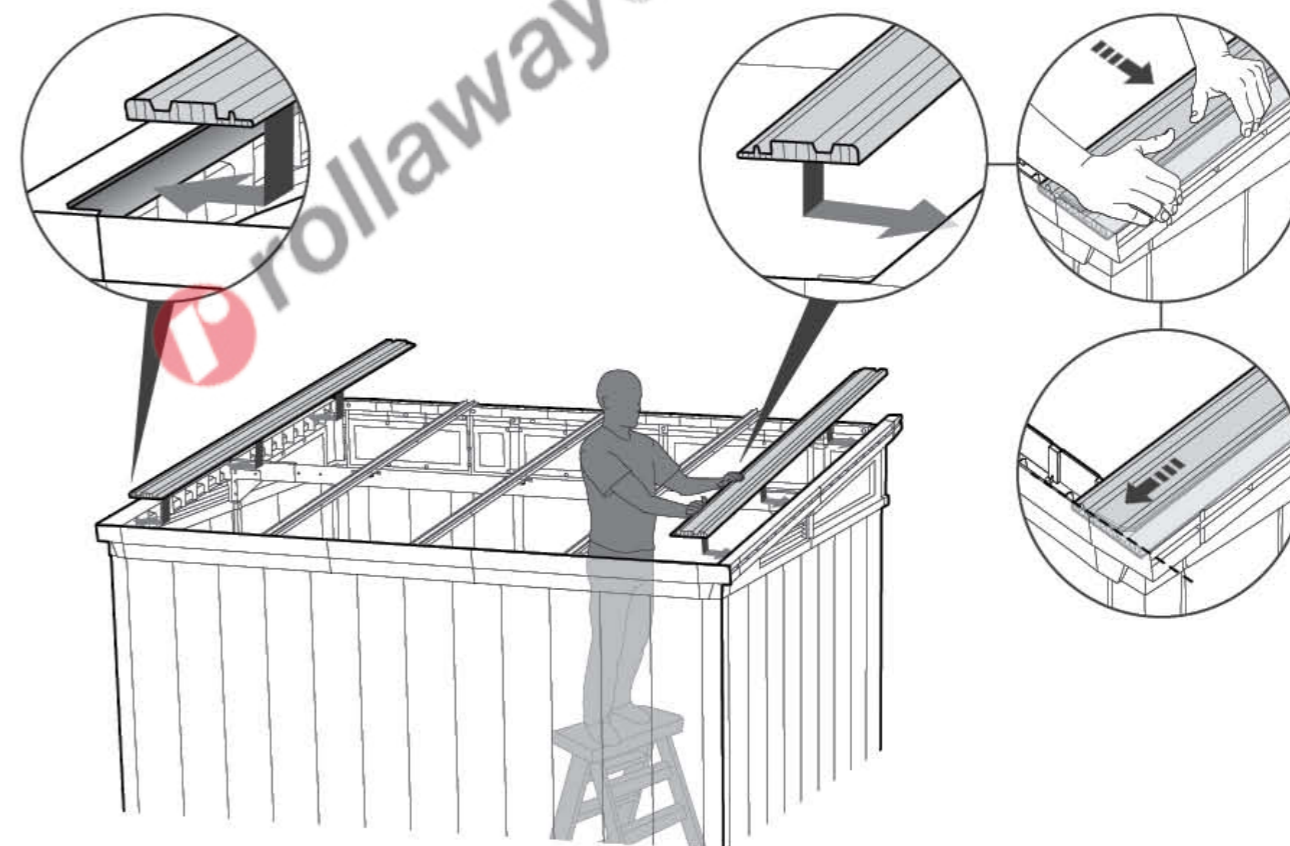

48



NEPR (x4)



NERK (x4)

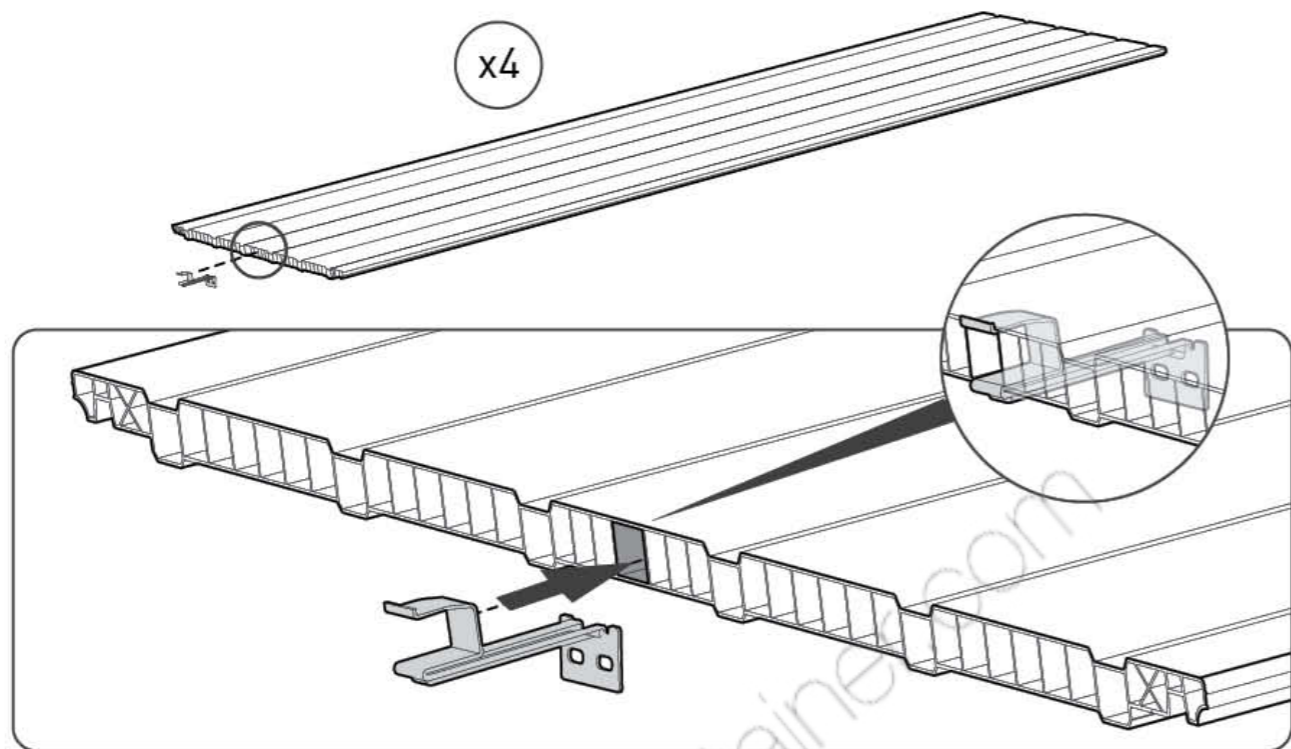

49



NEPR (x4)

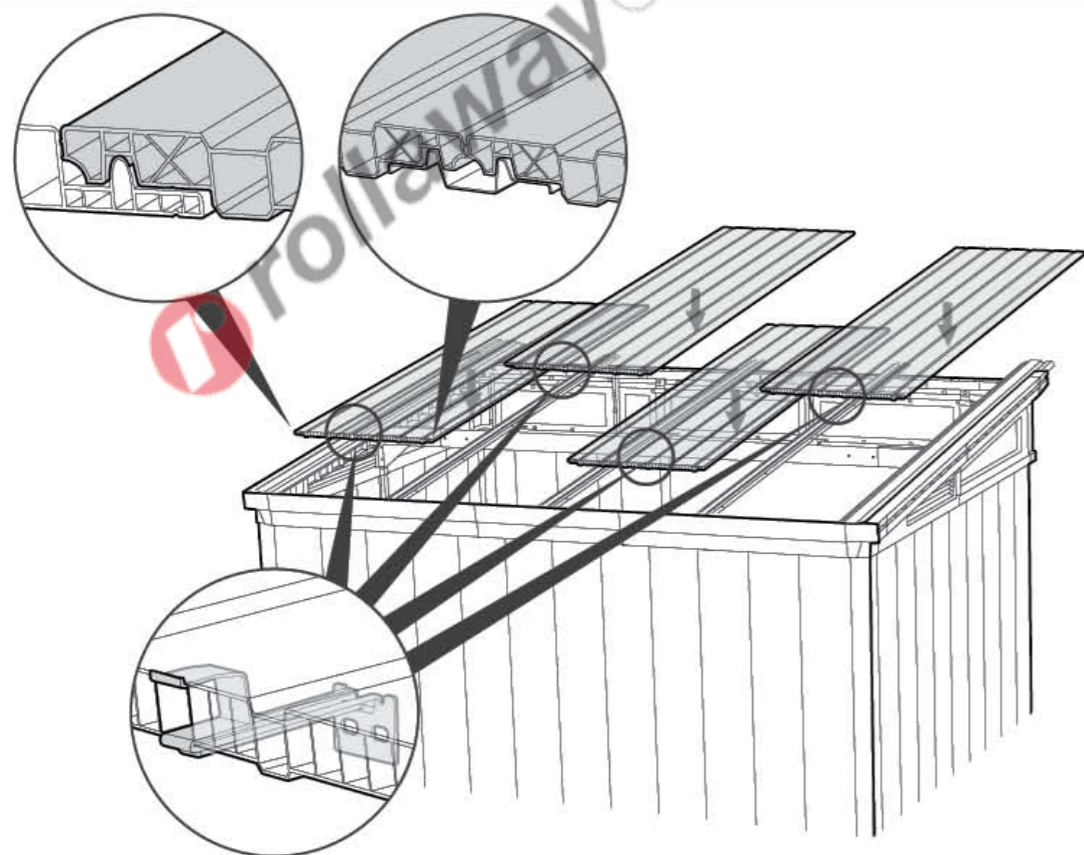

50



sc15 (x8)

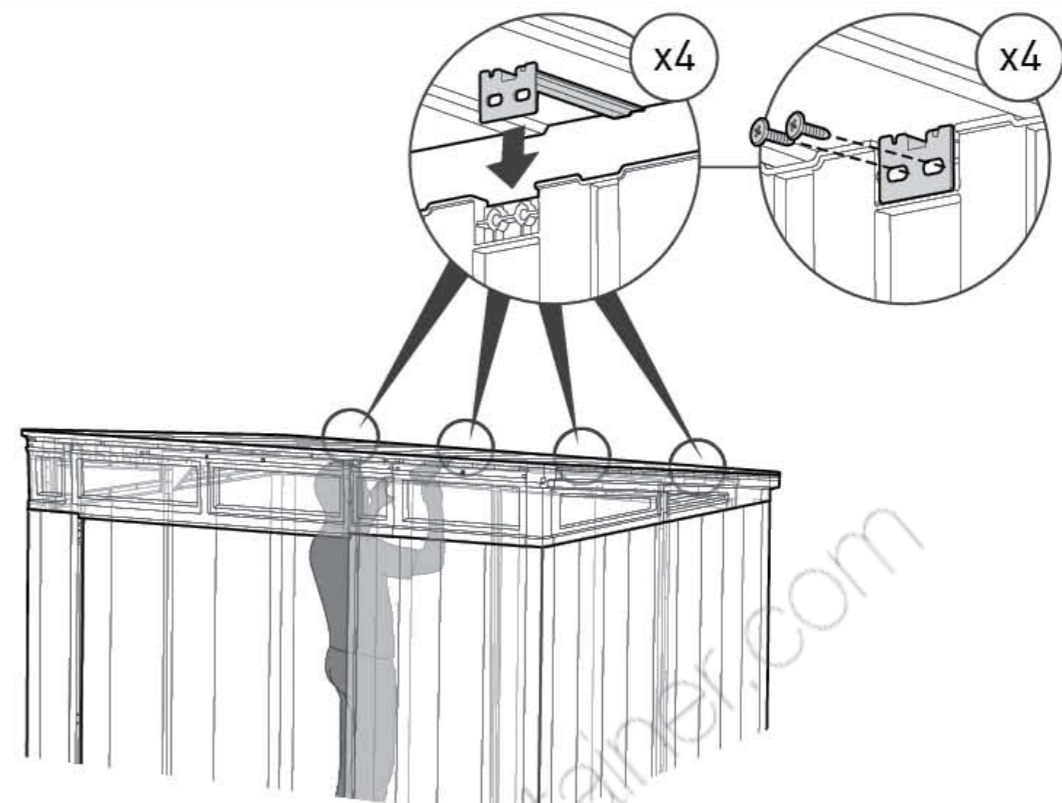

51



NELC (x1)



NERC (x1)



NECE (x1)



sc15 (x4)

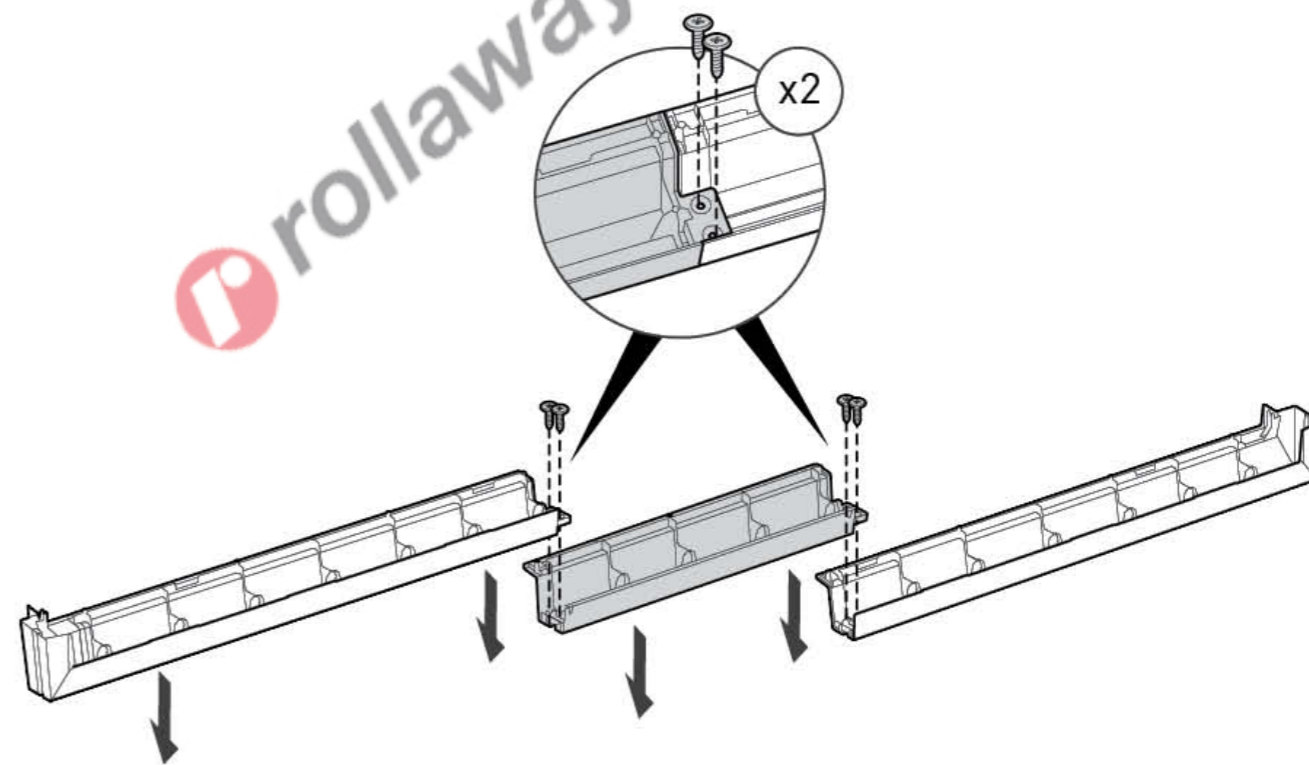

52



sc15 (x11)

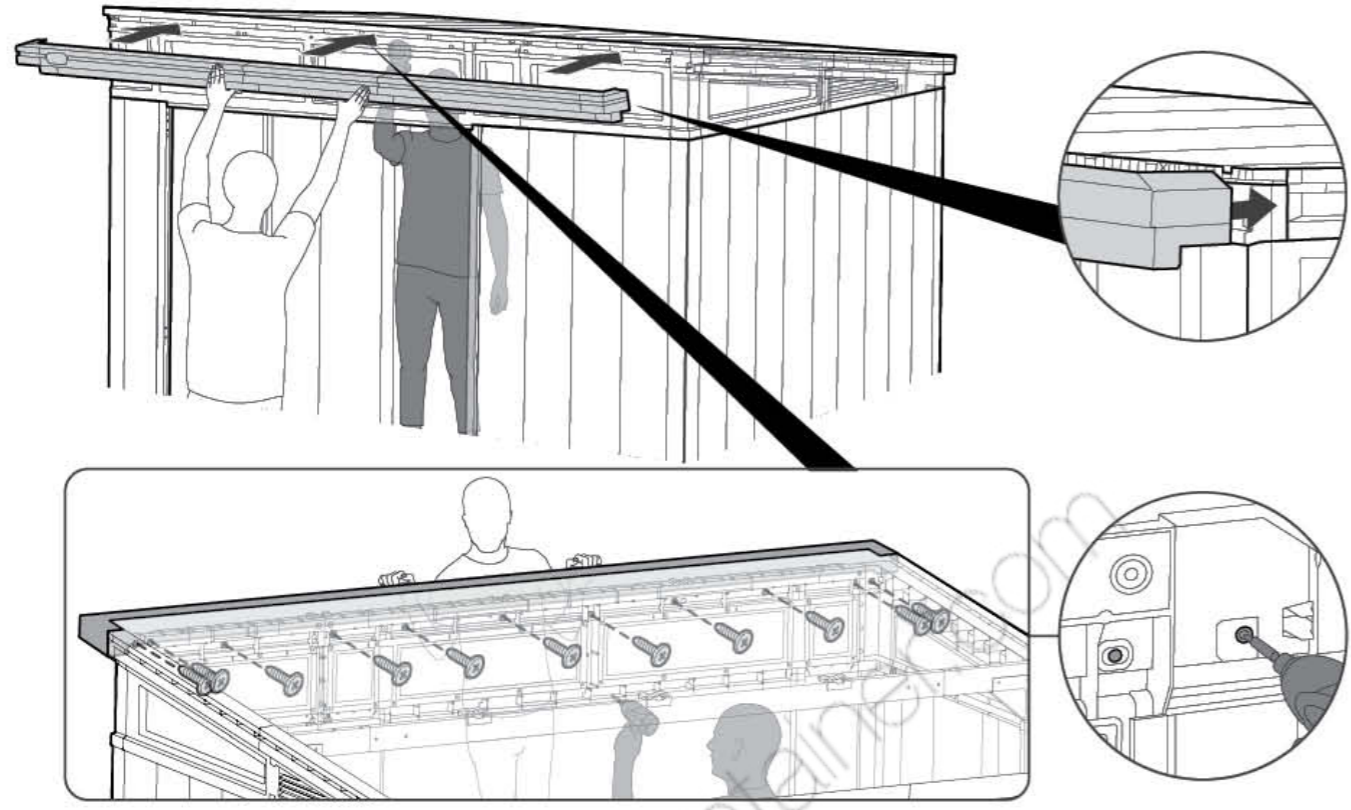

53



scw1 (x30)

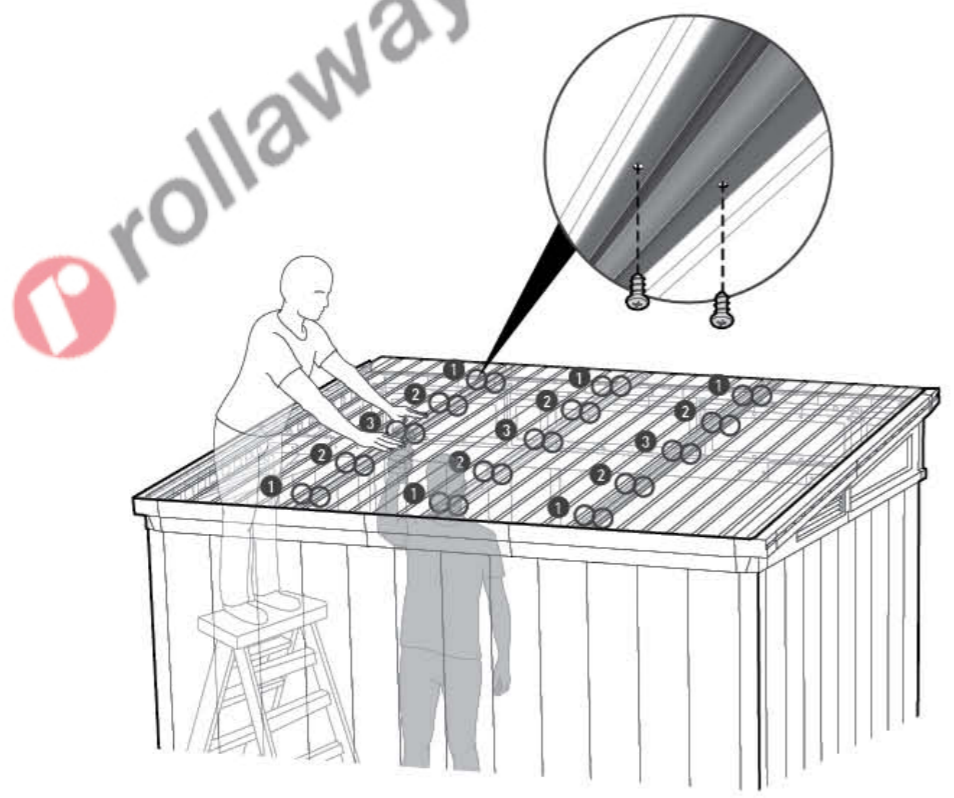

54



scw1 (x8)

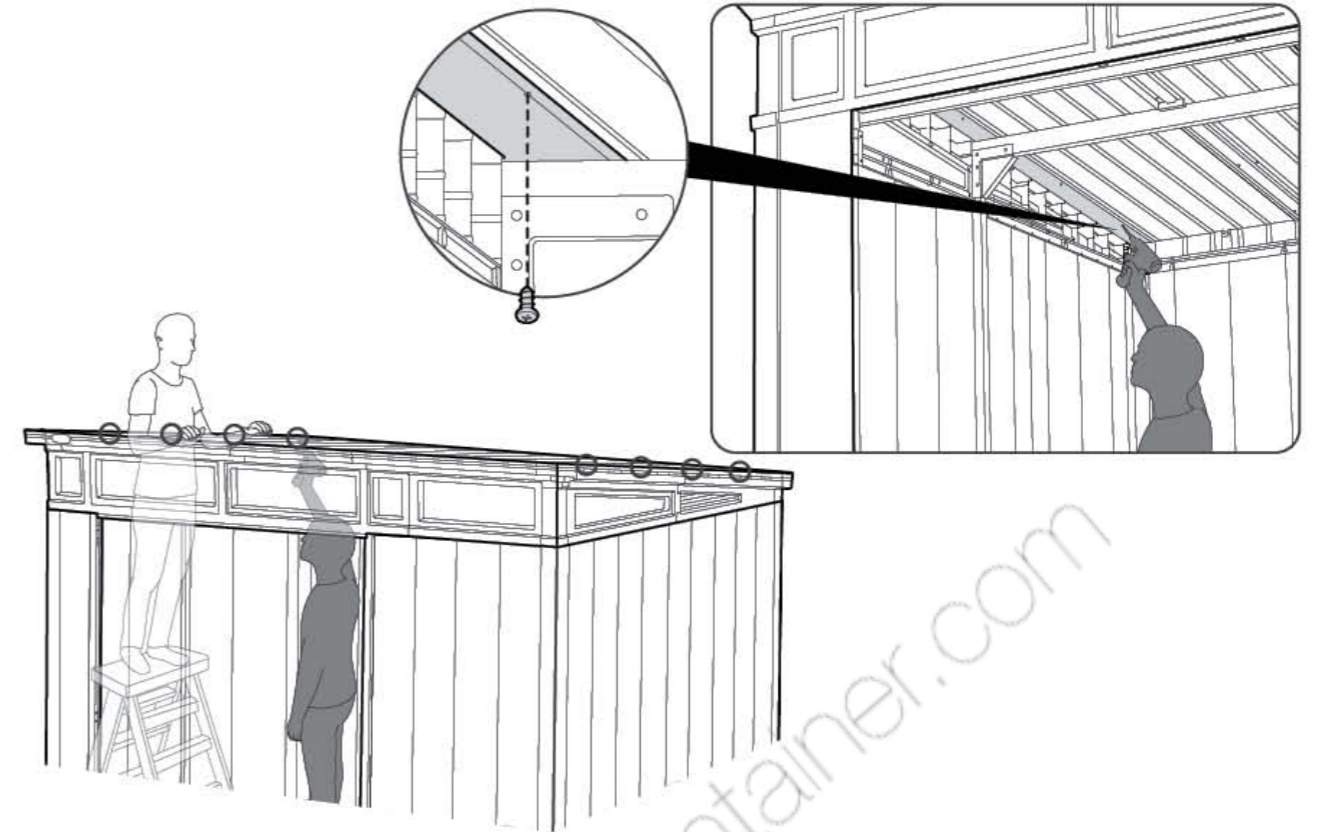

55

sc15 (x26)

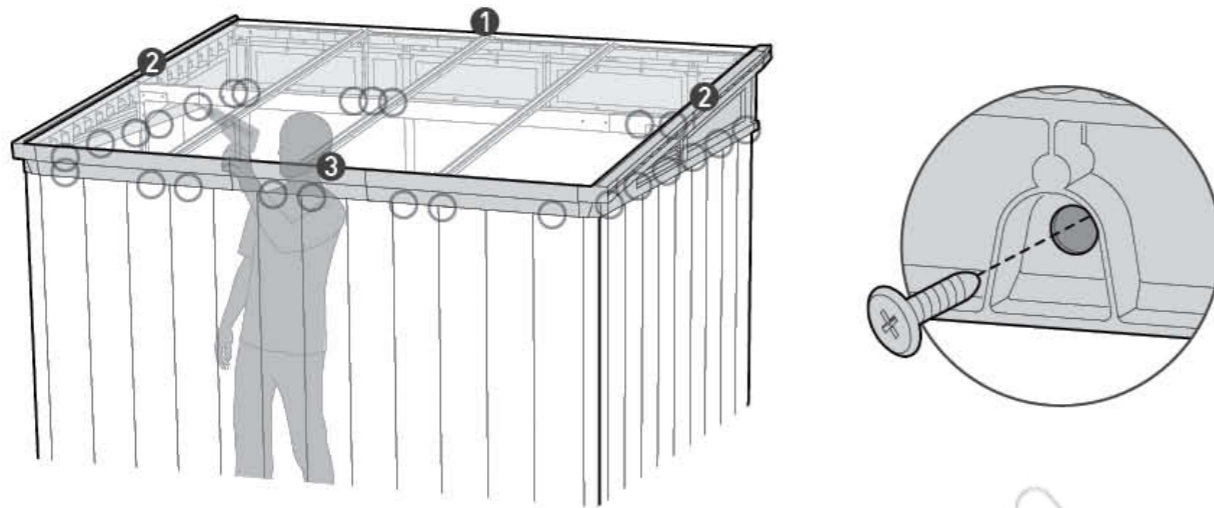

Front | Avant | Delante | Vorderseite | Voorkant | Anteriore | Frente

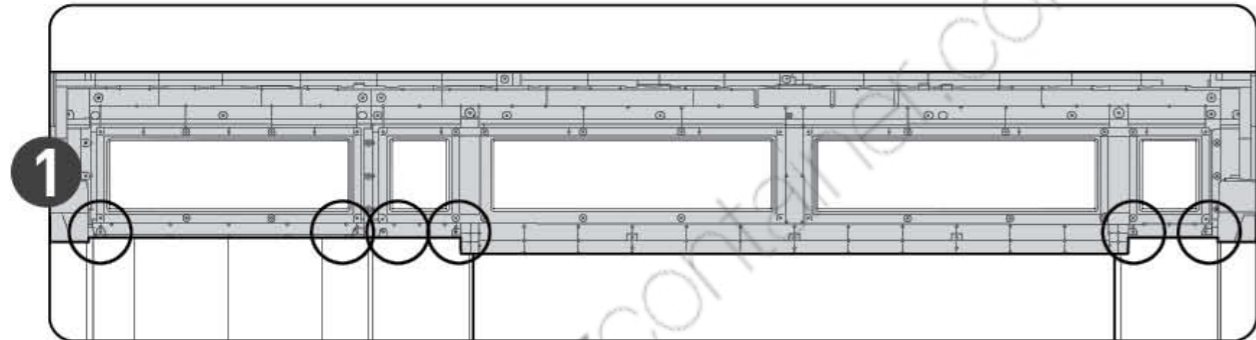

Right | Droit | Derecho | Richtig | Rechts | Destra | Direito
Left | Gauche | Izquierdo | Verließ | Links | Sinistra | izquierdo

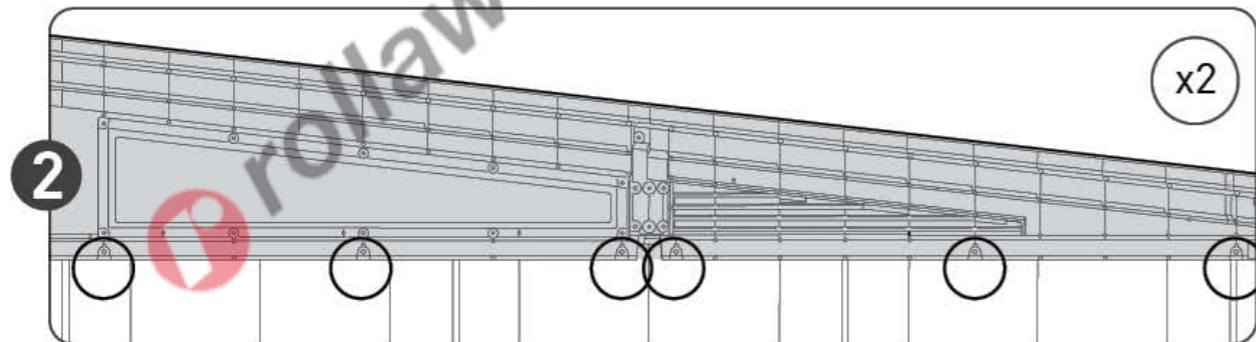

back

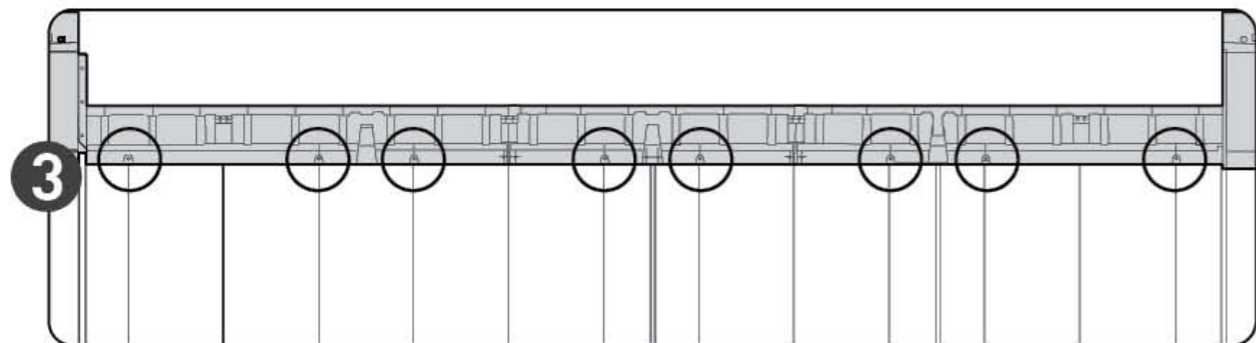

56

s13b (x15)

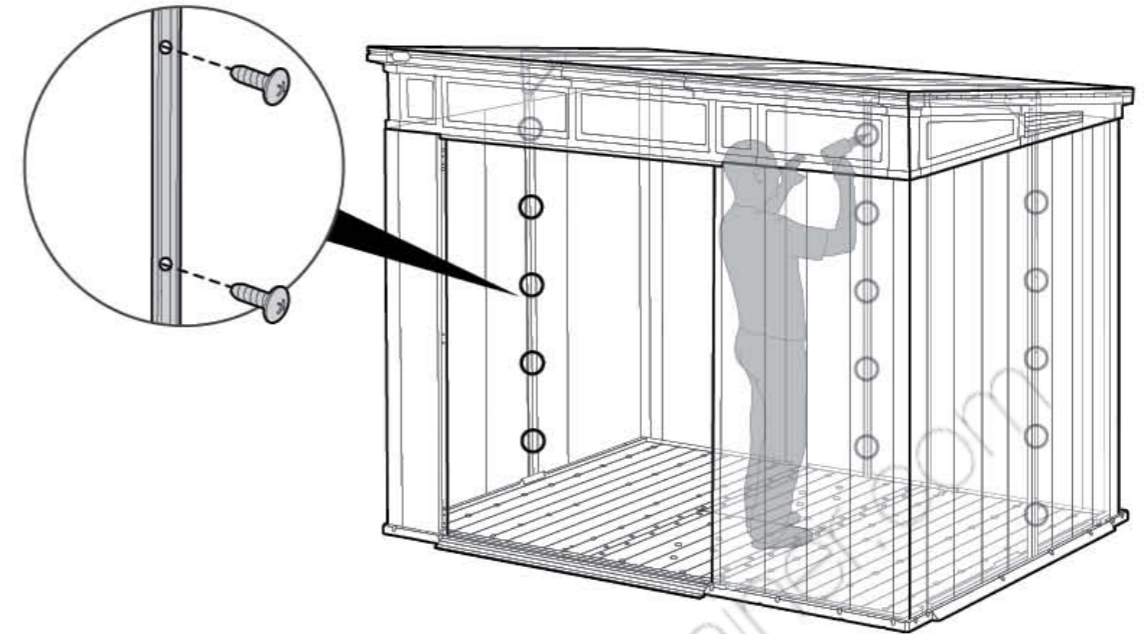

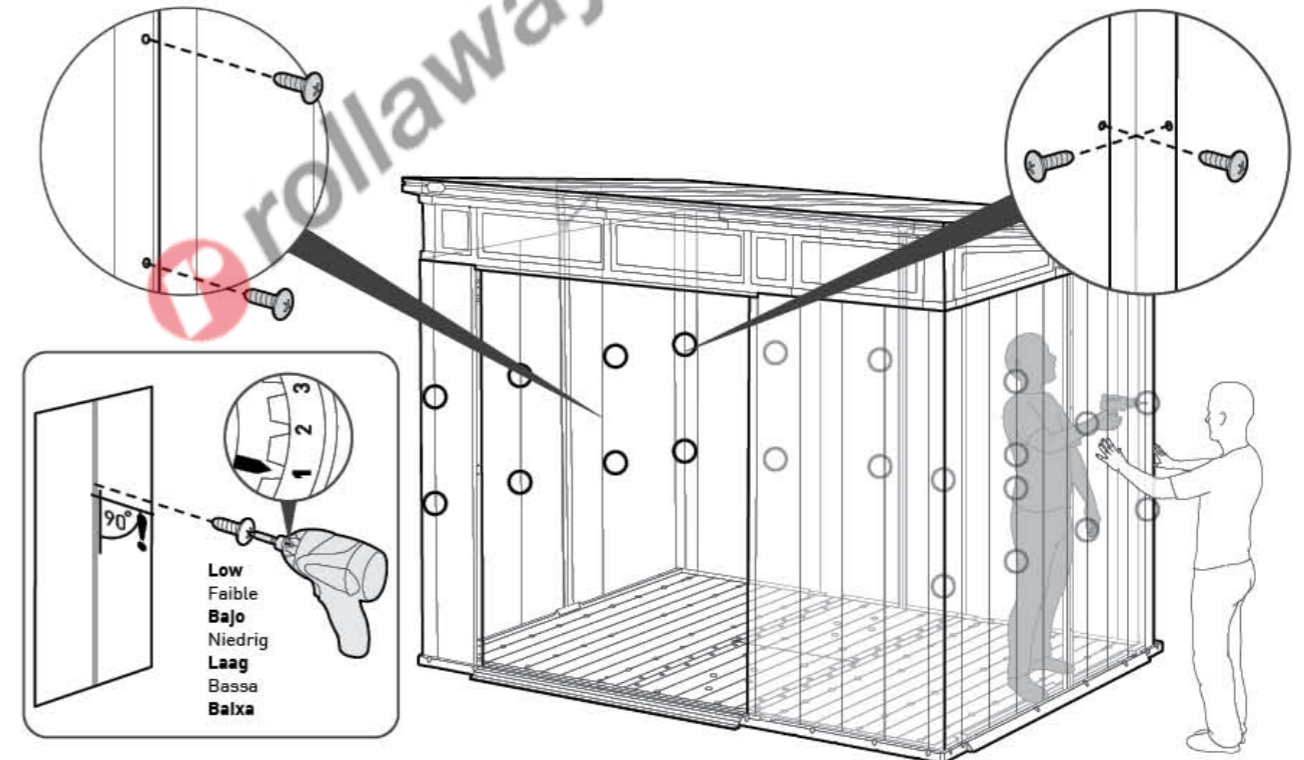

57

s13b (x30)



DOOR ASSEMBLY | MONTAGE DE LA PORTE | ARMADO DE LA PUERTA | MONTAGE DER TÜR | DEURMONTAGE | MONTAGGIO DELLA PORTA | MONTAGEM DA PORTA

58 |  NEDC (x4) |  NEDMC (x8) |  sf13 (x16)

x4

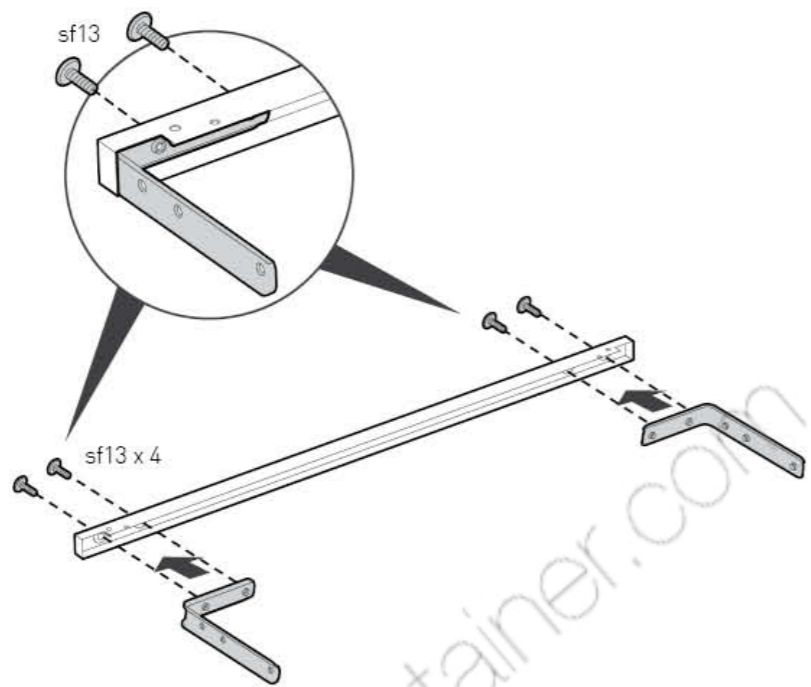

59 |  NEDO (x2)

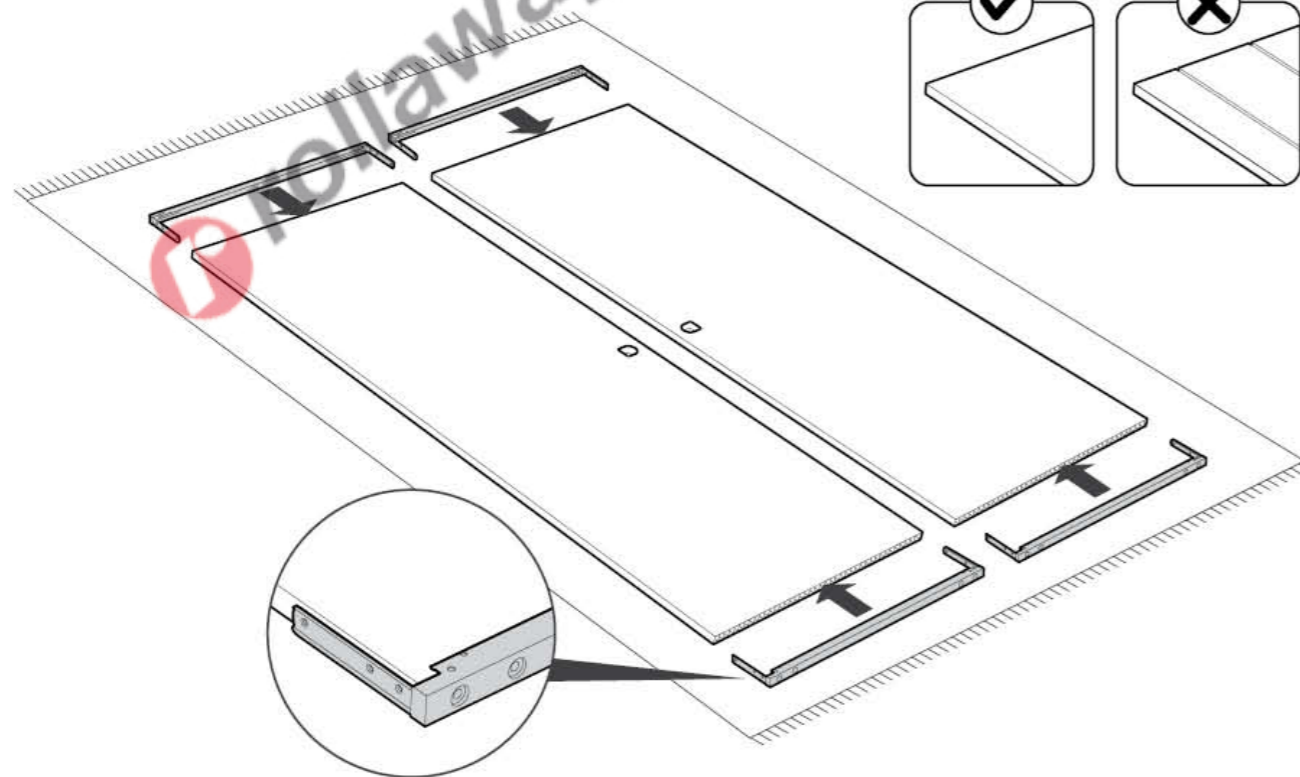
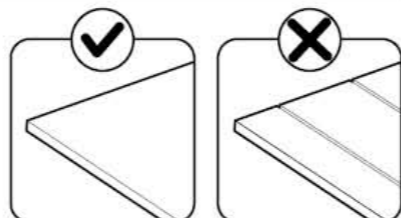

60 |  NEDSO (x2) |  NEDSI (x1) |  NEDSW (x1)

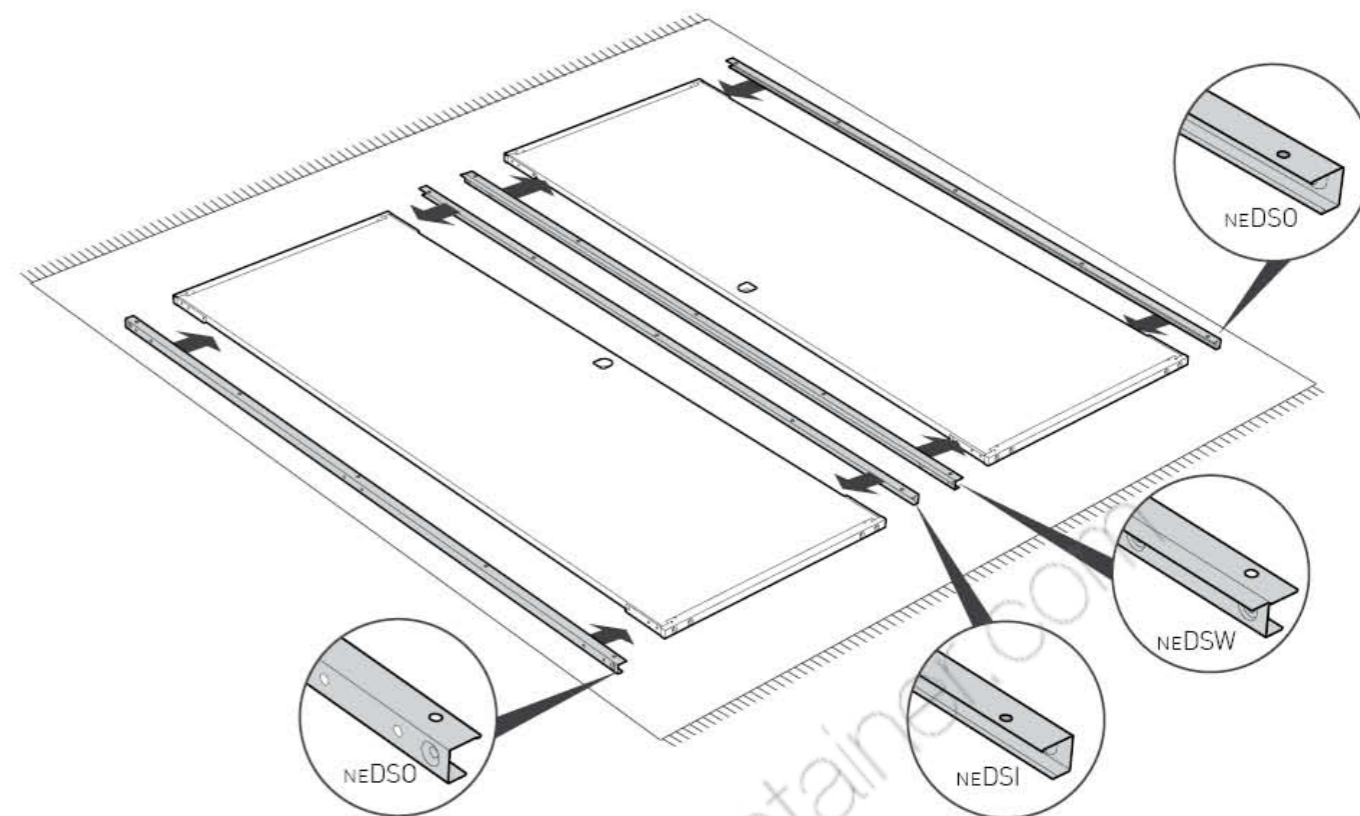

61 |  sc15 (x12)

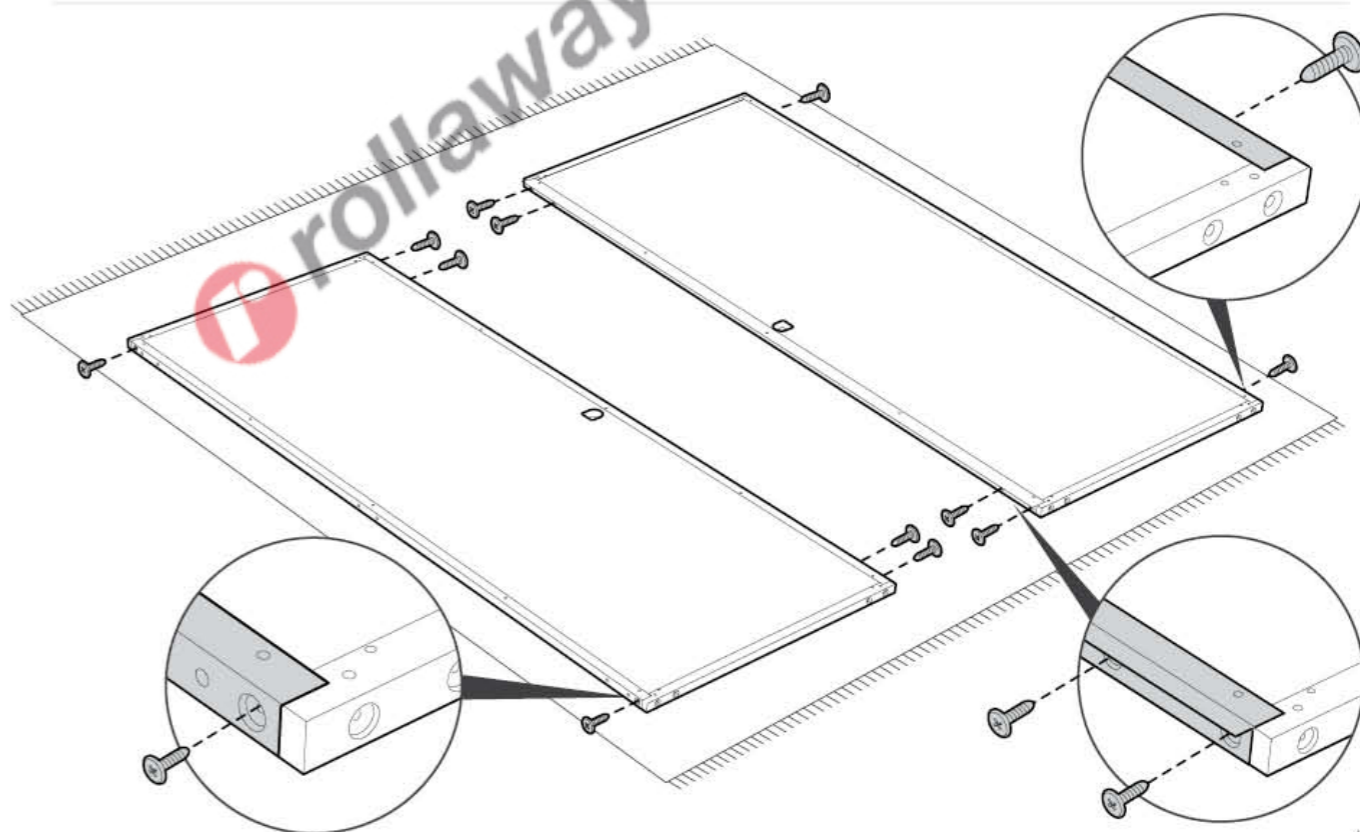

62



NEMBH (x2)



sc15 (x4)

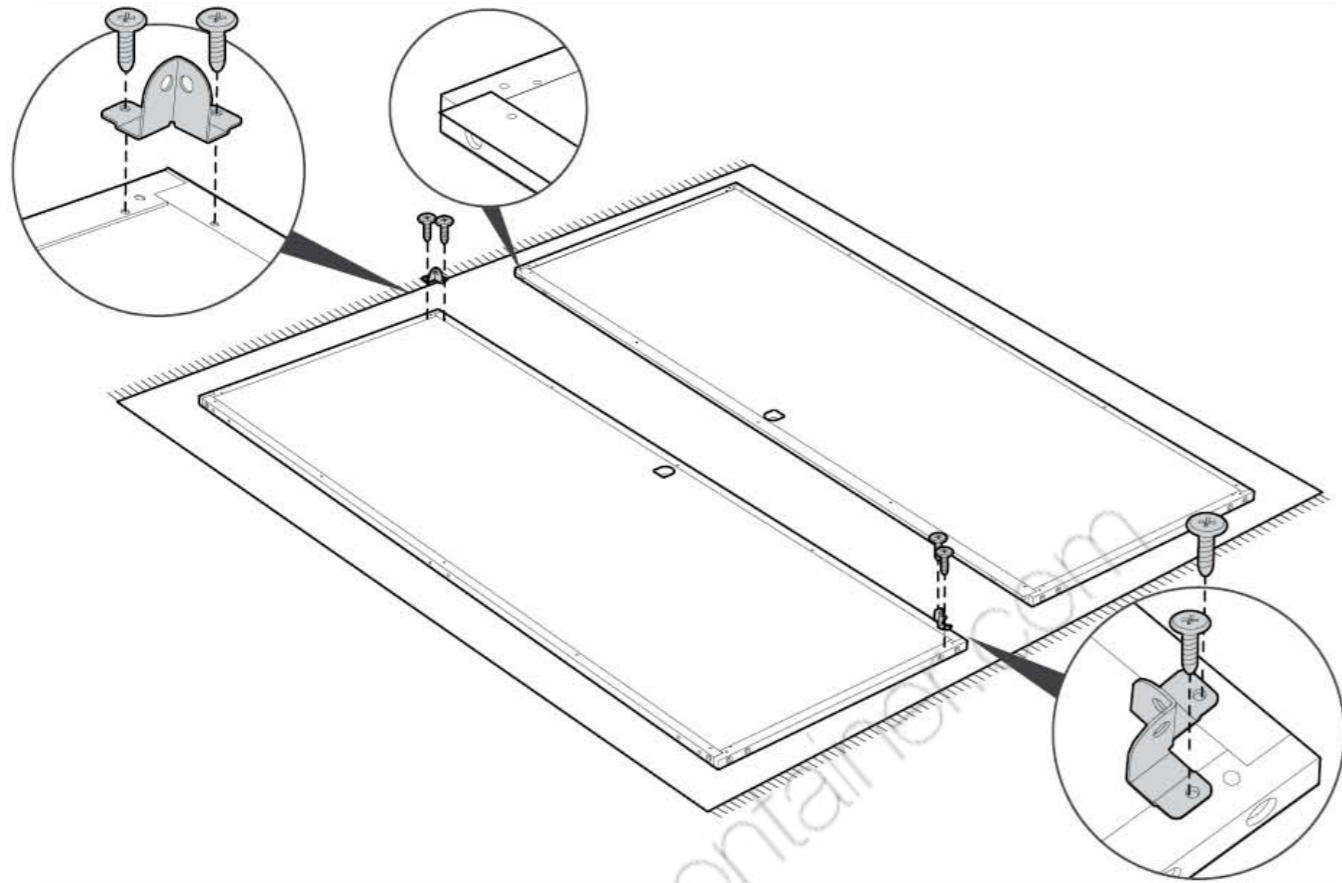

63



sc15 (x26)

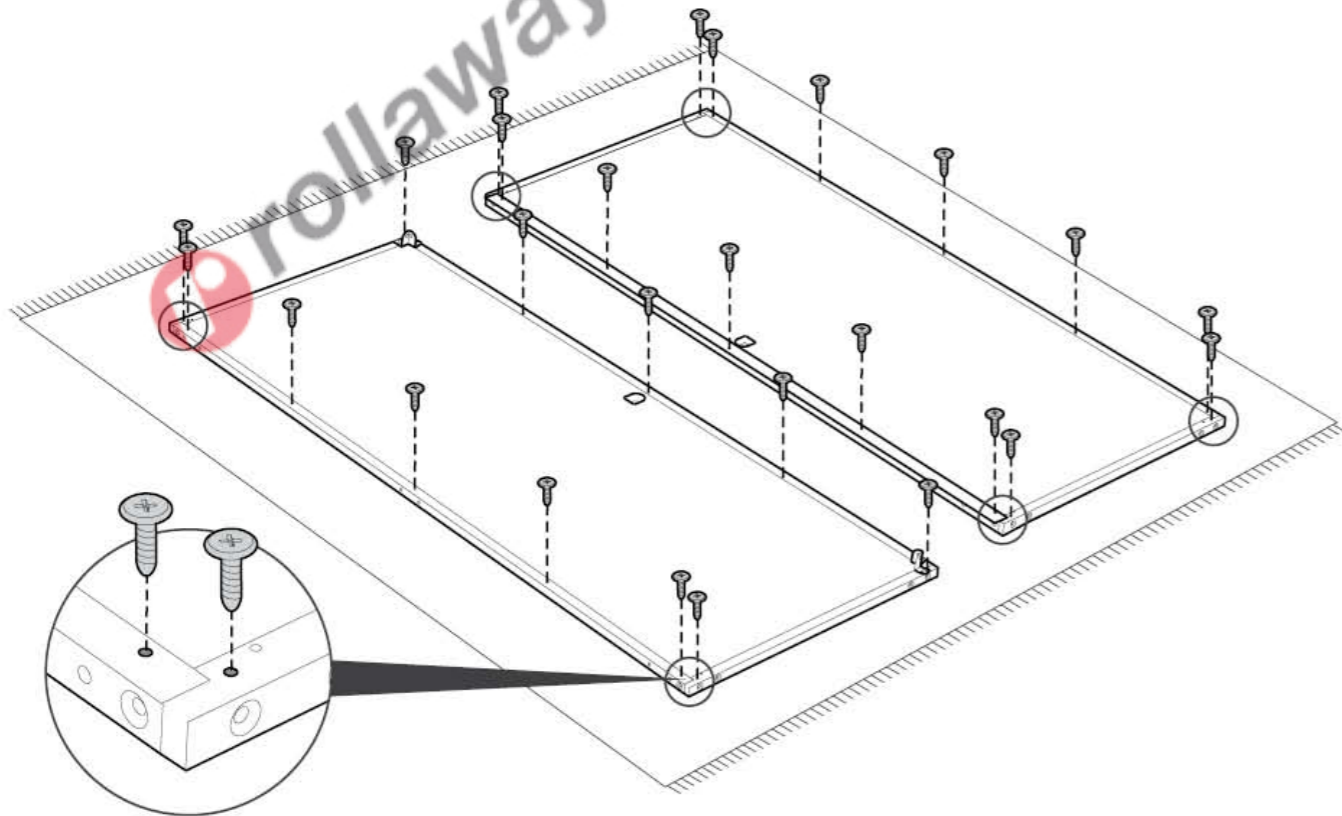

64



NEDH (x6)



sc15 (x12)

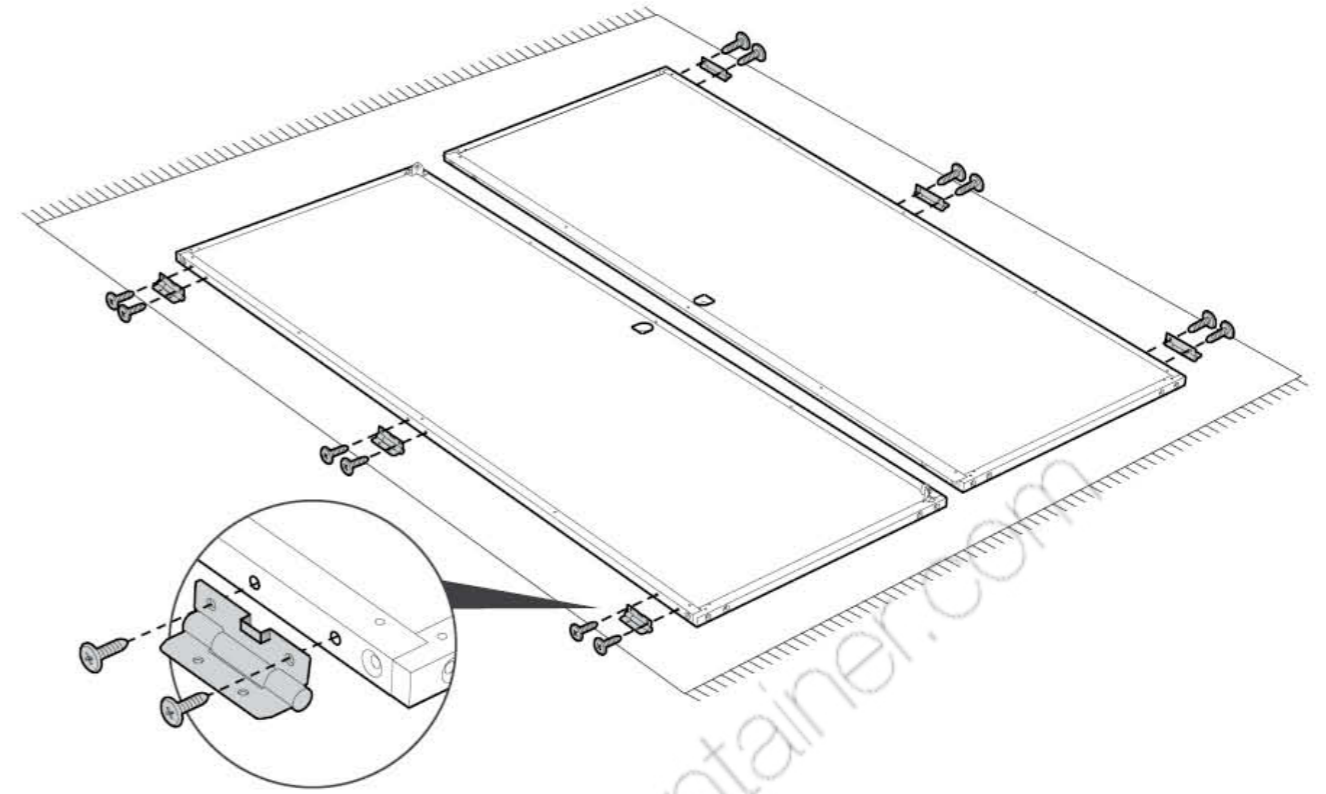

65



sc15 (x2)

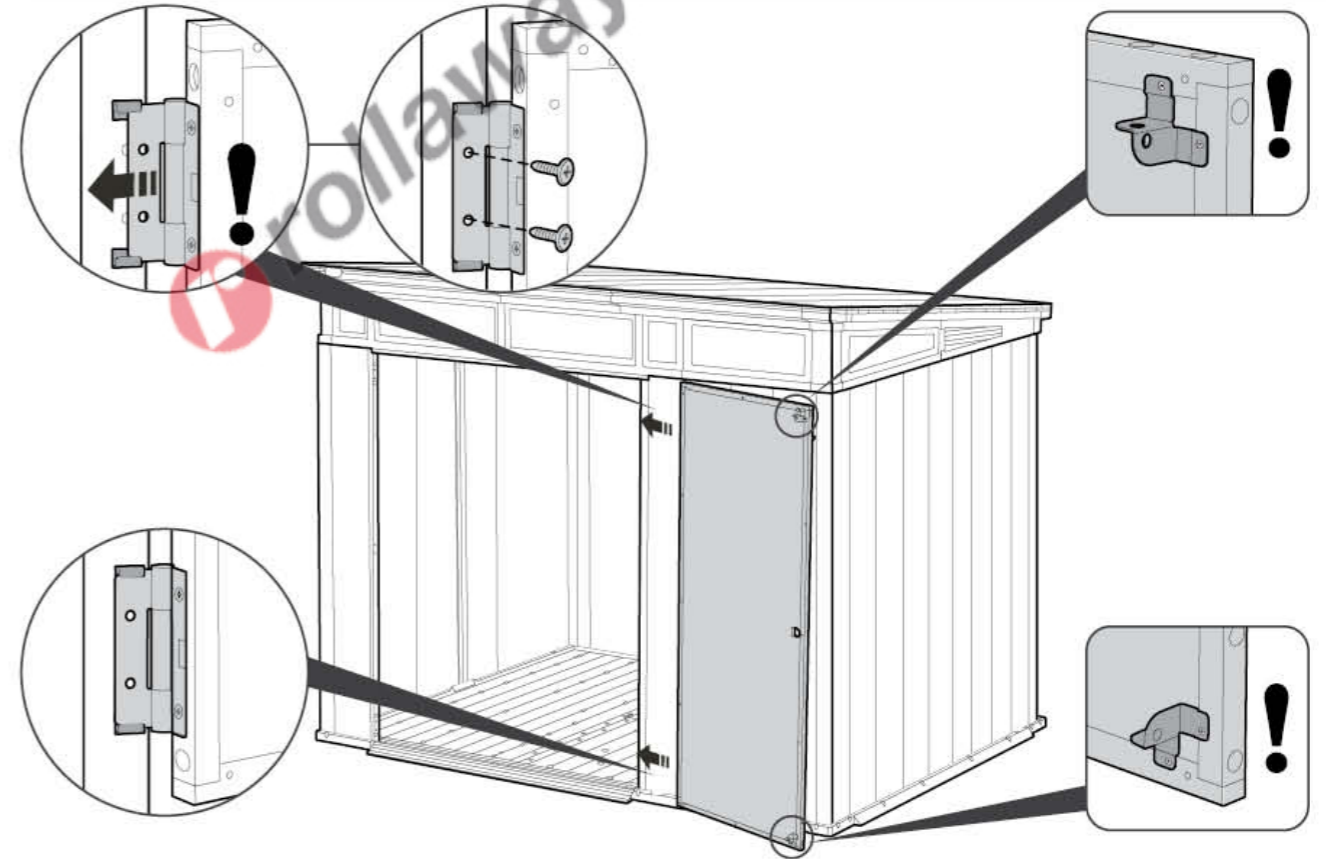

66

sc15 (x2)

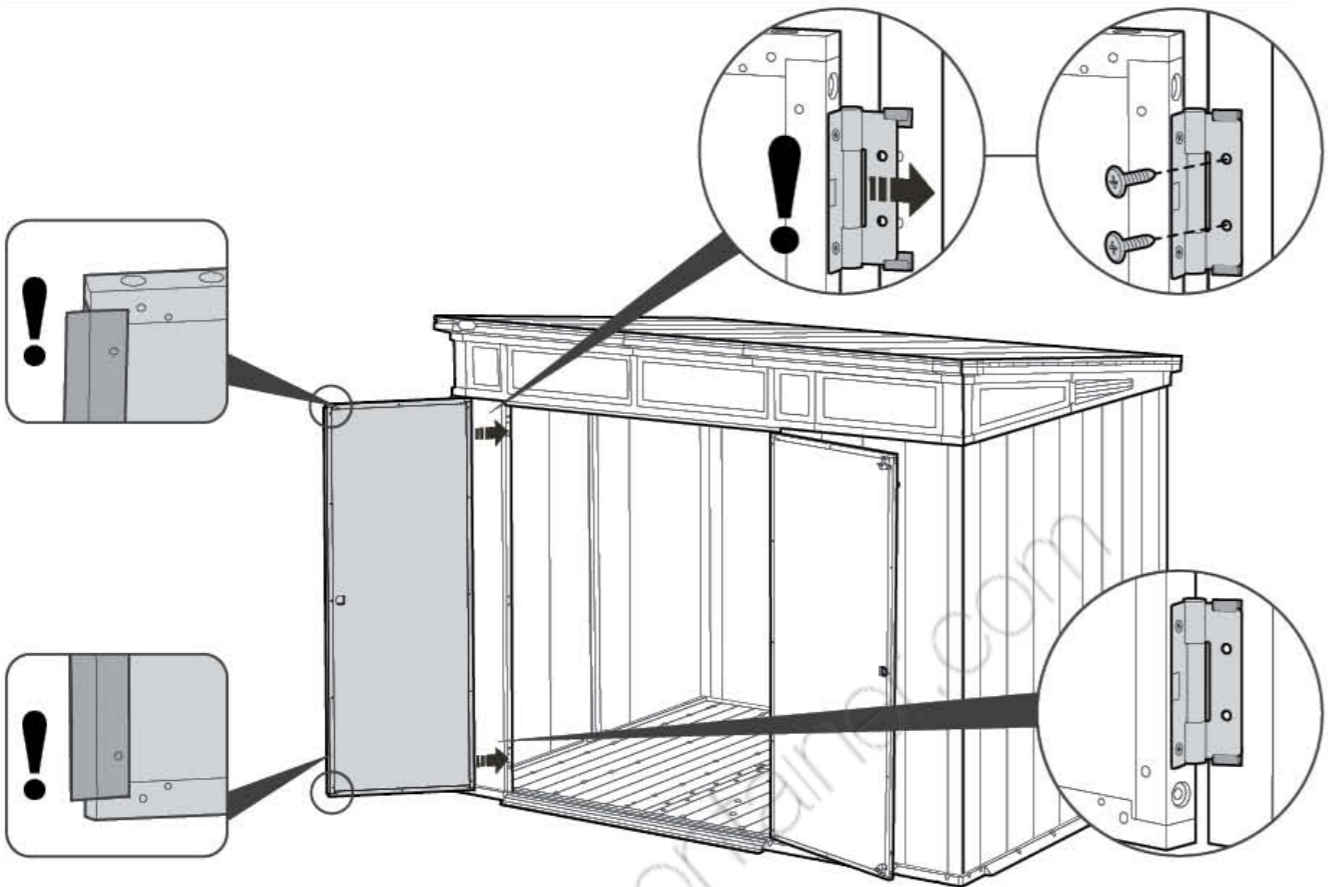

rollaway.com

67

NEDPC (x2)

sc15 (x4)

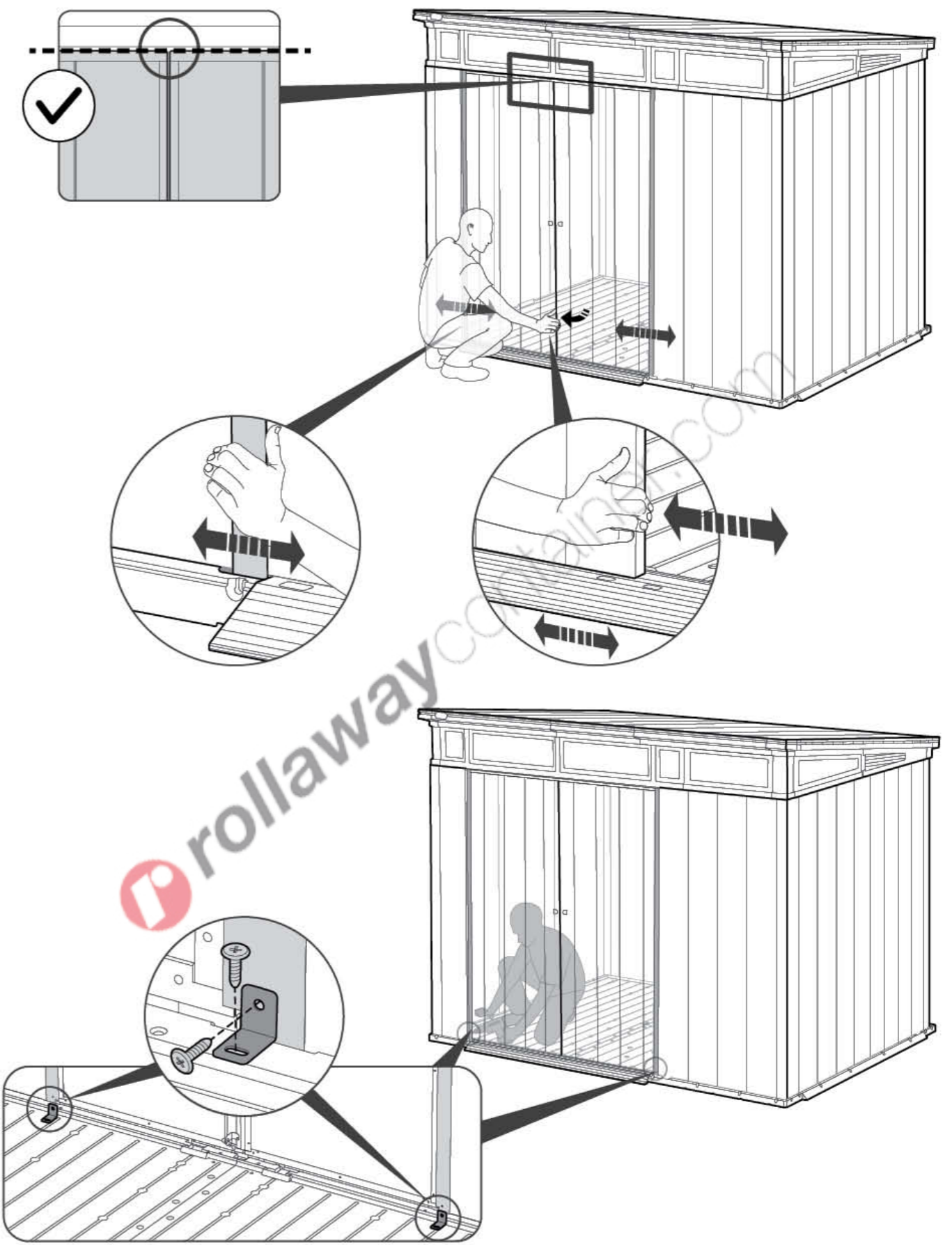

rollaway.com

68

sc15 (x8)

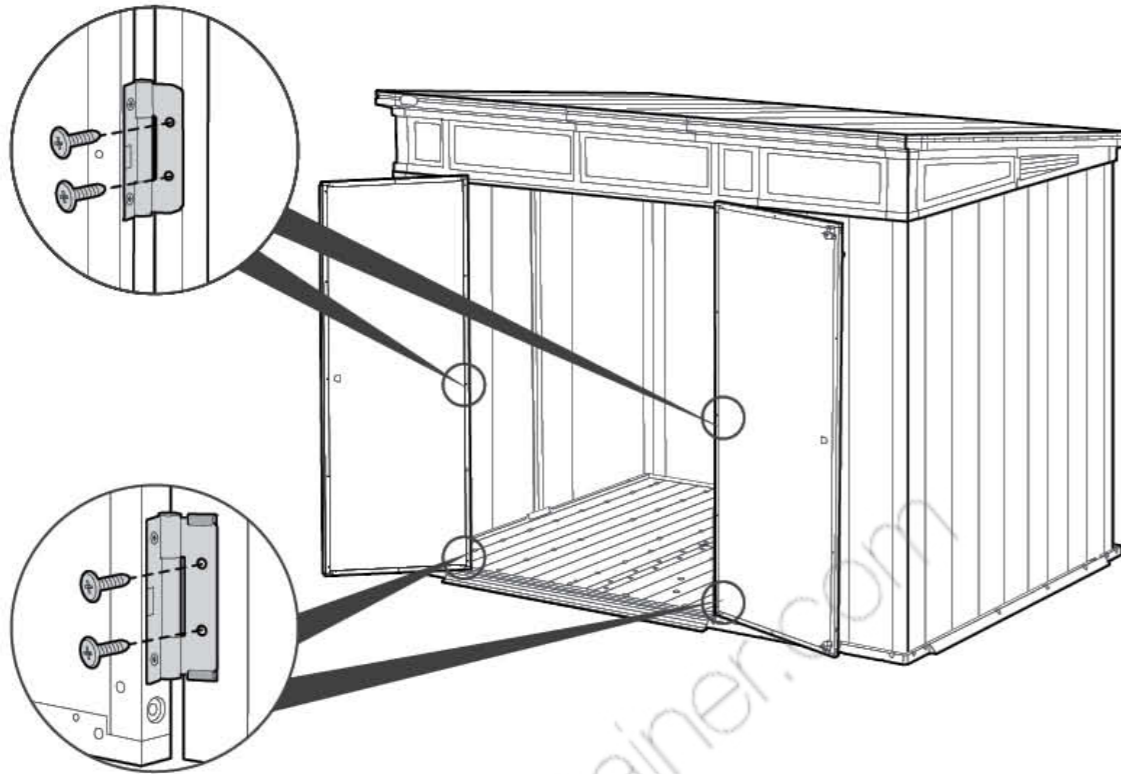

69

sc15 (x8)

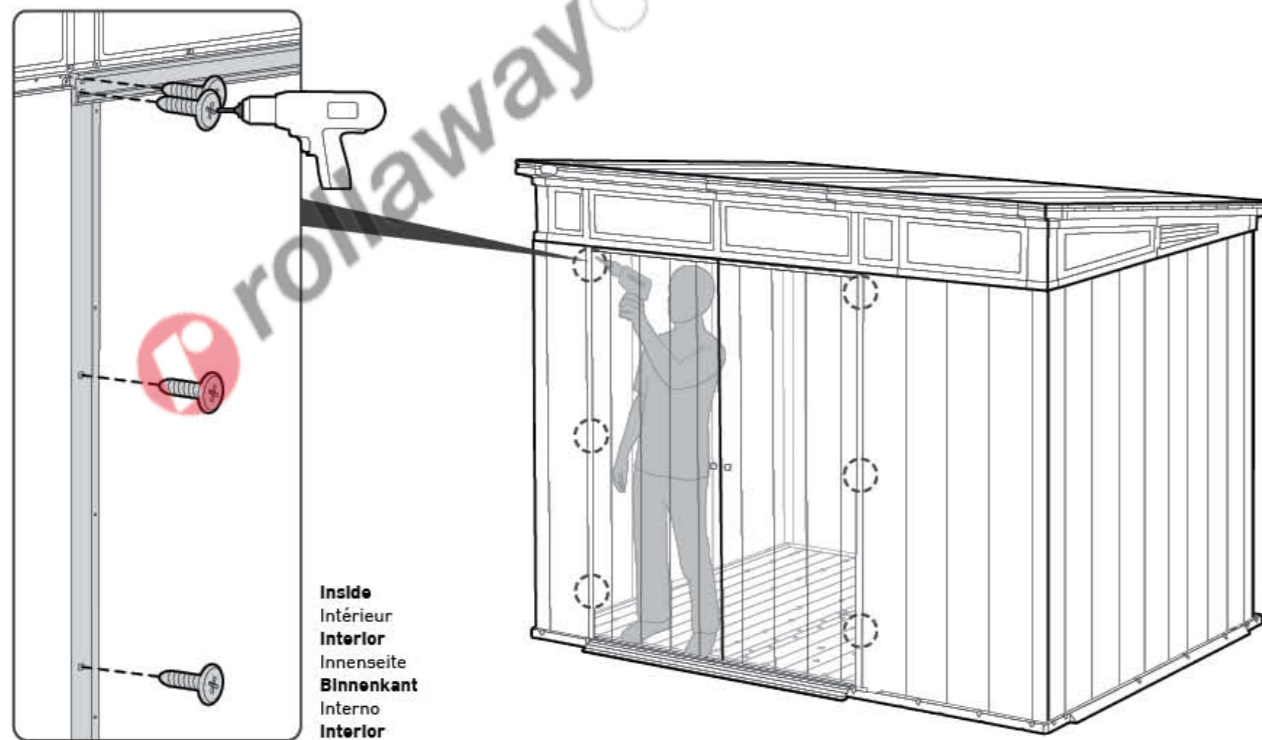

70

sc15 (x8)

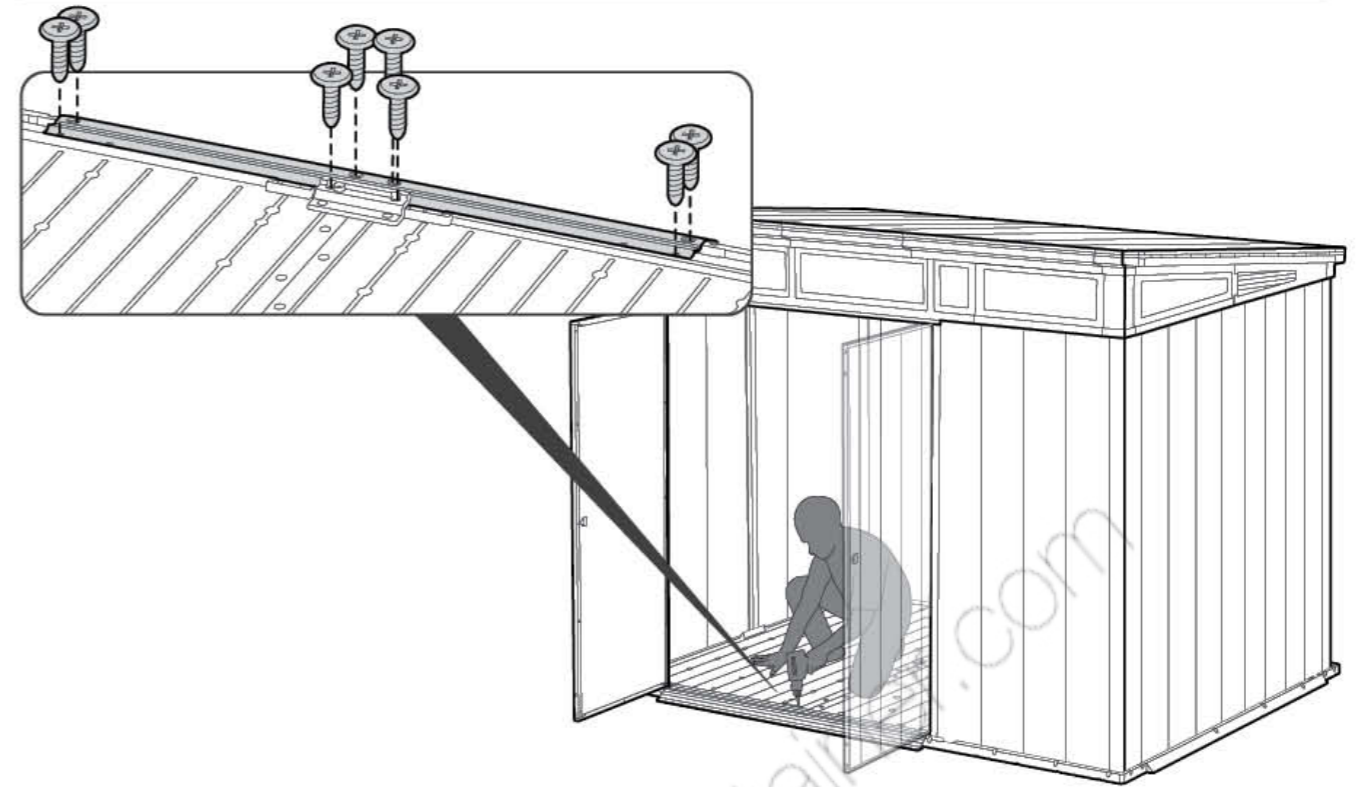

71

NEHE (x1)

FNH6 (x1)

NEHF (x1)

sc15 (x1)

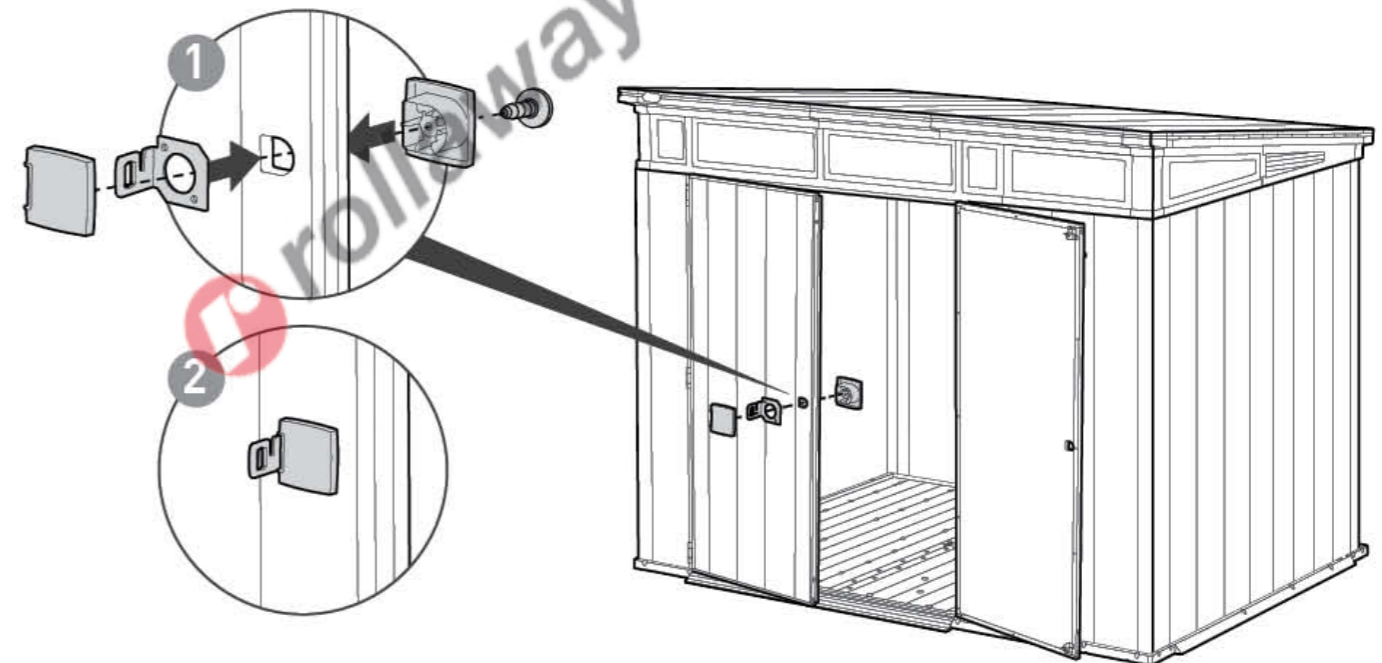

72

NEHA (x1) FNH7 (x1) scn8 (x1) sc15 (x2)

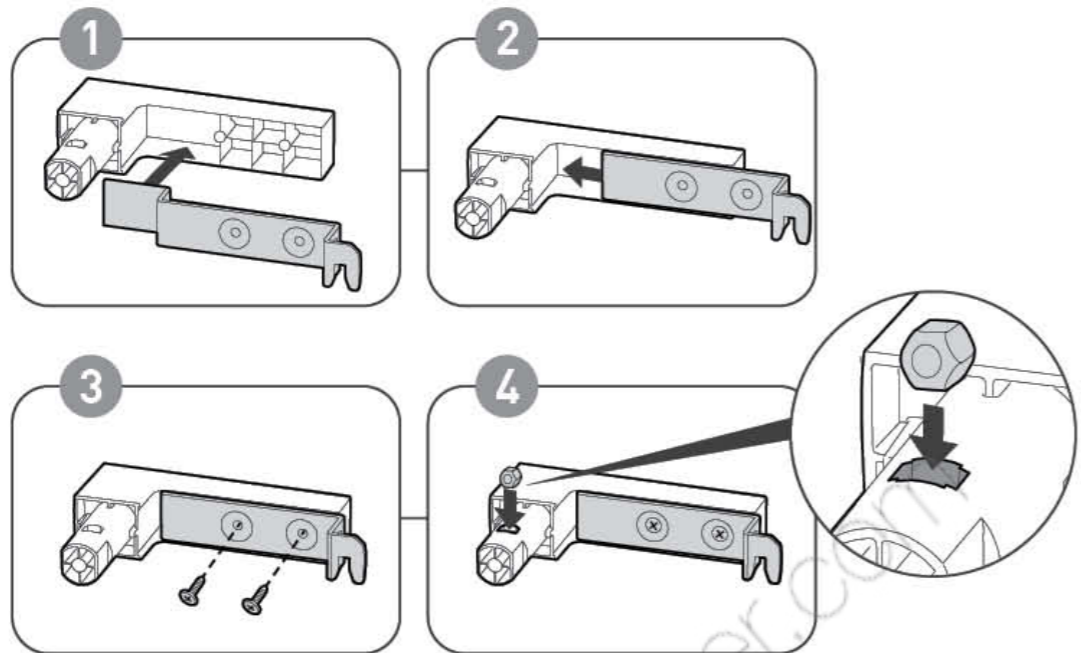

73

NEHB (x1) NEHC (x1) NEHG (x1) sc8 (x1)

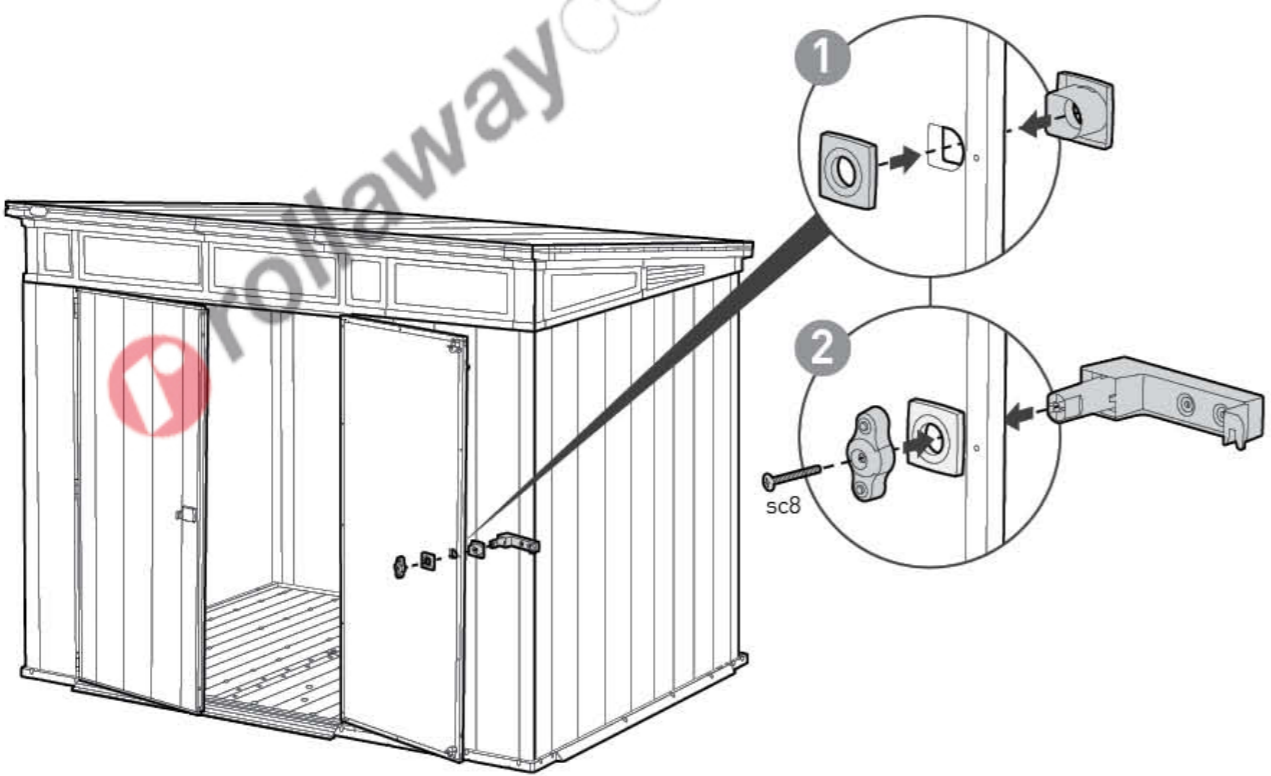

74

NEMB (x2) sc15 (x2)

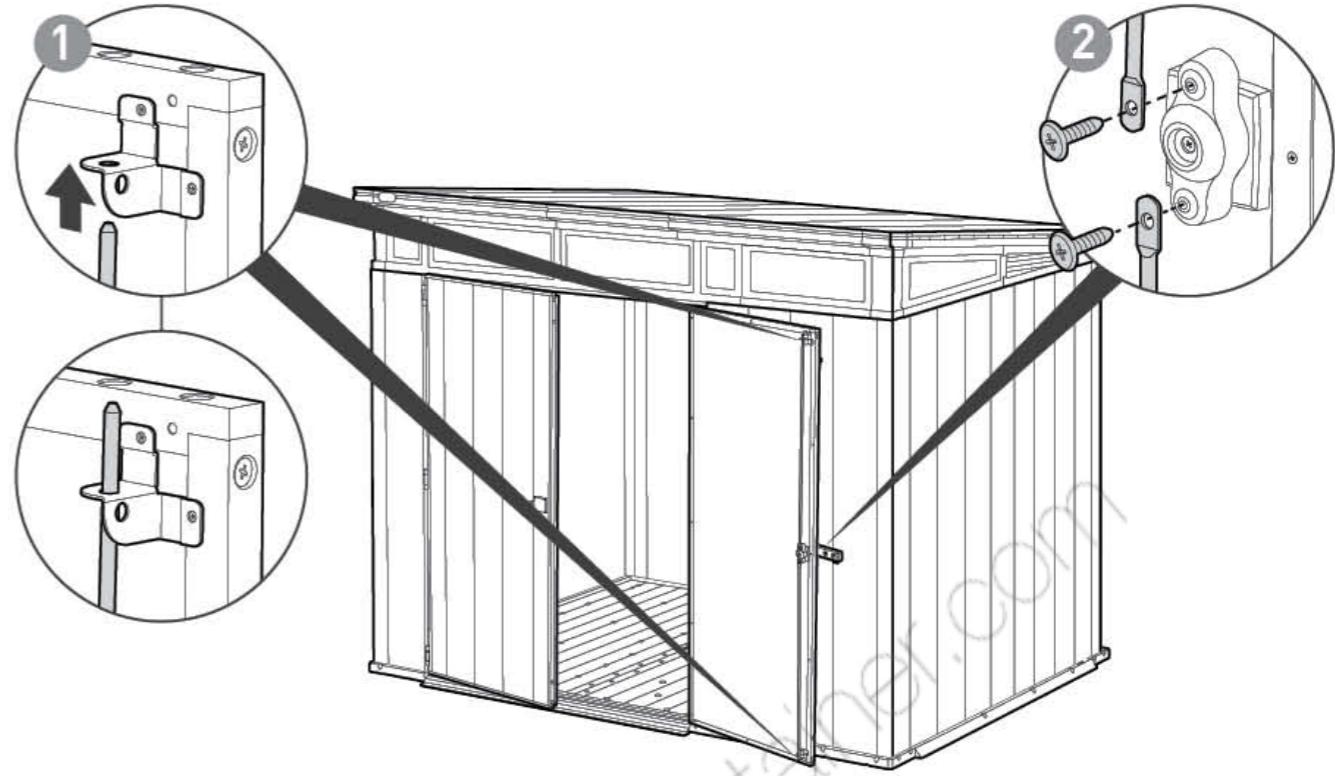

75

sc12 (x32)

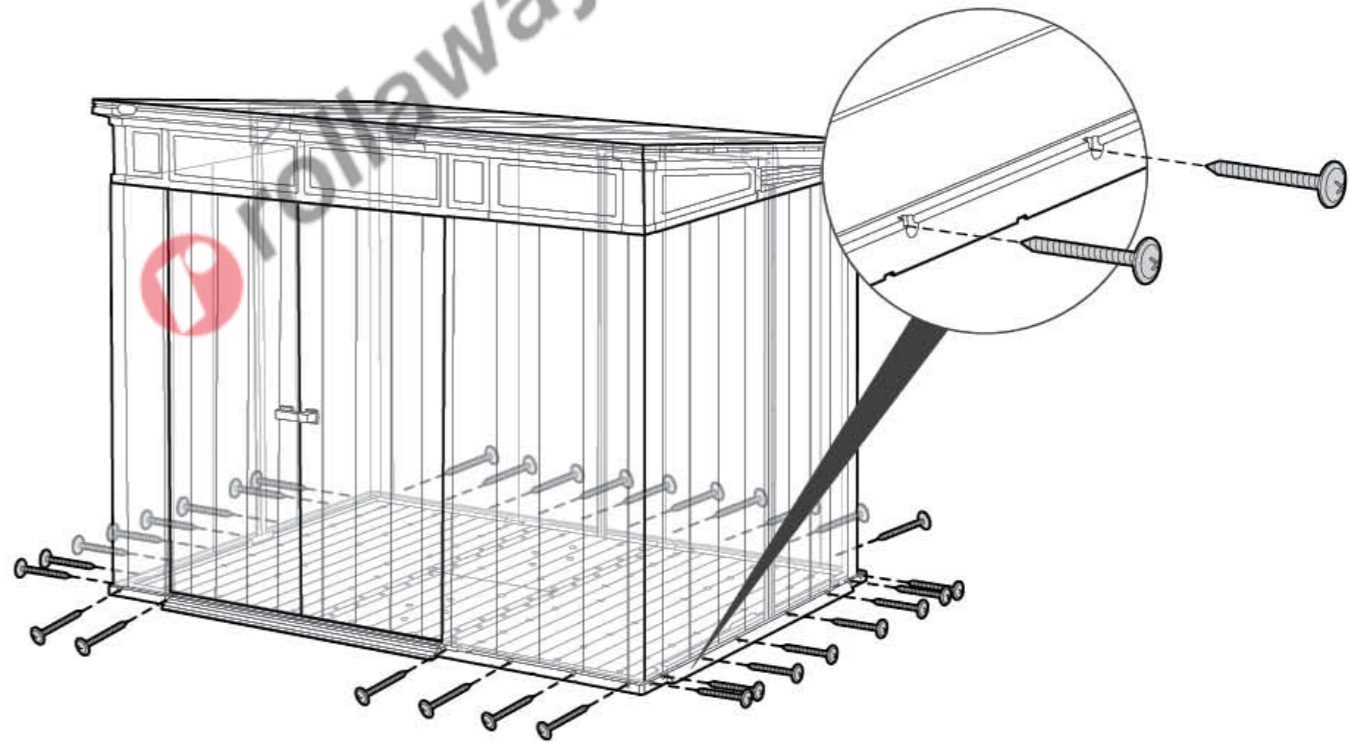

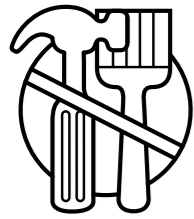

This shed is maintenance free. Paint or varnish are not necessary.

Cet abri ne nécessite aucun entretien. Peindre ou vernir n'est pas nécessaire.

El cobertizo no necesita mantenimiento. Tampoco hay que pintarlo ni barnizarlo.

Dieser Schuppen benötigt keine Wartung. Streichen oder Lackieren ist nicht notwendig.

Dit schuurtje is onderhoudsvrij. Het is niet nodig het te schilderen of te lakken.

Questo deposito attrezzi non richiede manutenzione. Non sono necessari pittura o vernici.

Este abrigo não requer manutenção. A pintura ou o envernizamento não são necessárias.



DUOTECH™ SHEDS - UNIQUE PAINTABLE WALLS

This maintenance-free shed is made of a unique compound which enables the brushed wall-panels to be painted.

The shed can be used in its original color, or the walls can be painted to match your landscape, deck, patio, or outdoor setting.

Prior to painting, refer to the detailed care and maintenance instructions:

- Type of paint: The walls of the shed can be painted with a water-based acrylic paint for exterior use.

Recommended:

Solid, light shades, satin or semi-gloss finish. Consult with your color consultant or paint professional when choosing paint.

- Application: Use a roller to apply the paint on the wall dry surface. Do not paint the beam-like crevices in the walls.

- Do not paint windows, doors or door beam, roof, floor, or any other part of the shed.

Keep in mind: Painting requires maintenance. After some time, repainting may be required.

* For your safety - make sure you follow the paint's care & safety guide prior to application.

ABRIS DUOTECH™ - PAROIS POUVANT ÊTRE PEINTES

Ce placard n'a pas besoin d'aucun entretien et est fait d'un composé unique permettant de peindre les panneaux muraux brossés.

Le placard de jardin peut être utilisé dans sa couleur d'origine, ou les murs peuvent être peints pour s'harmoniser avec le paysage, la terrasse, le patio ou les éléments extérieurs. Avant de peindre, consultez les instructions détaillées et le mode d'emploi :

- Type de peinture : les murs de l'abri peuvent être peints avec une peinture acrylique à base d'eau prévue pour l'extérieur. Recommandation : finitions en teintes unies, tons clairs, satinés ou semi-lustrés. Suivez les indications de votre conseiller ou votre peinture lors de votre choix.

- Application : utilisez un rouleau pour appliquer la peinture sur la surface bien sèche des murs. Ne peignez pas les éléments de support dans les murs.

- Ne peignez ni les fenêtres, ni les portes ou le tour de porte, ni le toit, ni le sol, ni aucun autre élément constituant de l'abri (seulement les murs).

Rappelez-vous : la peinture exige un certain entretien. Après un certain temps, il peut être nécessaire de repeindre.

* Pour votre propre sécurité, suivez bien les instructions d'utilisation de la peinture avant la première application.

COBERTIZOS DUOTECH™ - PAREDES PINTABLES ÚNICAS

Esta caseta que no requiere mantenimiento, está hecha de un compuesto único que permite pintar las paredes. La caseta se puede utilizar con su color original o se pueden pintar las paredes para que combinen con el entorno, el patio o los alrededores.

Antes de pintarlo, consulte las instrucciones detalladas de cuidado y mantenimiento:

- Tipo de pintura: Las paredes del cobertizo se pueden pintar con una pintura acrílica de base acuosa para uso en exteriores. Se recomienda: sólida, sombras ligeras, satinada o con un acabado de semibrillo. Consulte con su profesional de pinturas cuando vaya a elegir una pintura.

- Aplicación: Utilice un rodillo para aplicar la pintura sobre la superficie seca de la pared. No pinte las hendiduras similares a vigas de las paredes.

- No pinte ventanas, puertas o vigas de la puerta, el suelo o cualquier otra parte del cobertizo.

Tenga en cuenta: pintar requiere mantenimiento. Después de algún tiempo podría necesitar otra mano de pintura.

* Para su seguridad, asegúrese de que sigue la guía de cuidado y seguridad de la pintura antes de su aplicación.



DUOTECH™ GARTENHAUS - INDIVIDUELL ANSTREICHBARE WÄNDE

Dieser wartungsfreie Schrank besteht aus einer einzigartigen Verbindung, welches es ermöglicht, die gebürsteten Wandpaneele zu streichen.

Sie können den Schrank in seiner ursprünglichen Farbe nutzen oder dessen Wände streichen, um ihn der Landschaft, Terrasse oder Umgebung anzupassen.

Bitte lesen Sie vor dem Streichen die ausführlichen Wartungs- und Pflegehinweise:

- Art der Farbe: Die Wandpaneele können mit einer Acrylfarbe auf Wasserbasis angestrichen werden. Unsere Empfehlung: Solide und helle Farbtöne mit mattem oder seidenmattem Finish. Sprechen Sie bezüglich Ihrer Farbwahl mit einem Farbberater oder einem professionellen Maler.

- Applikation: Verwenden Sie eine Farbrolle, um die Farbe auf die trockene Wandoberfläche aufzutragen. Bitte streichen Sie nicht die Zwischenräume der einzelnen Paneele.

- Fenster, Türen, Türträger, Dach, Boden und jegliche andere Teile des Gartenhauses bitte nicht anstreichen! Bitte beachten Sie: Streichen erfordert Instandhaltung und Pflege. Daher kann nach einiger Zeit ein Neuanstrich erforderlich sein.

* Achtung: Beachten Sie vor dem Streichen die Pflege- und Sicherheitshinweise der Farbe.

DUOTECH™-SCHUURTJES - UNIEKE SCHILDERBARE MUREN

Dit onderhoudsvrije stal wordt gemaakt van een unieke verbinding die de geborstelde wand-panels worden geveerd mogelijk maakt.

De schuur kan worden gebruikt in de originele kleur, of de wanden kunnen worden geschilderd om uw landschap, dek patio of outdoor setting, overeenkomen.

Voordat u gaat schilderen, verwijzen we u naar de gedetailleerde aanwijzingen voor verzorging en onderhoud:

- Type verf: de muren van het tuinhuis kunnen met een acrylverf op waterbasis voor buitengebruik worden geschilderd. Aanbevolen: stevige, lichte tinten, satijnglans of semi-glanzende afwerking. Raadpleeg uw kleurenadviseur of een professionele schilder bij het kiezen van de verf.

- Toepassing: gebruik een roller om de verf op de droge ondergrond van de muur aan te brengen. Schilder de balkachtige nerven in de muren niet.

- Schilder de ramen, deuren of de deurpost, het dak of enig ander deel van de schuur niet.

Houd er rekening mee dat schilderen onderhoud behoeft. Na enige tijd moet u het overschilderen.

* Voor uw veiligheid moet u ervoor zorgen dat u de zorg- en veiligheidsinstructies van de verf opvolgt voordat u deze gaat gebruiken.

PORTA ATTREZZI IN DUOTECH™ - PANNELI VERNICIABILI

Questa capannone è senza manutenzione e è realizzata con un composto unico che consente che i pannelli spazzolati dei muri siano pitturati.

Il capannone può essere utilizzata con il colore originario, oppure le pareti possono essere dipinte per adattarsi meglio all'ambiente circostante.

Prima di dipingere, fare riferimento alle istruzioni dettagliate su cura e manutenzione:

- Tipo di vernice: le pareti della casetta possono essere dipinte con una vernice acrilica ad acqua per uso esterno. Raccomandiamo: tinta poco diluita, ombreggiature leggere, rifiniture lucide o semilucide. Consultare un consulente per verniciature o un tinteggiatore professionista al momento di scegliere la vernice.

- Applicazione: utilizzare un rullo per applicare la vernice sulla superficie delle pareti a secco. Non dipingere le rientranze simili a putrelle sui muri.

- Non dipingere finestre, porte o la trave della porta, il tetto, il pavimento o qualsiasi altra parte della casetta.

Avvertenza: dipingere richiede manutenzione. Dopo qualche tempo potrebbe essere necessaria una ritinteggiatura.

* Per la vostra sicurezza - assicurarsi di seguire la cura e la sicurezza la guida vernice prima dell'applicazione.

DEPOSITO DUOTECH™ - PAREDES ÚNICAS PINTÁVEIS

Este galpão isento de manutenção é fabricado a partir de um composto exclusivo que permite a pintura dos painéis escovados da parede.

O galpão pode ser usado em sua cor original, ou as paredes podem ser pintadas para combinar com sua paisagem, terraço, pátio ou configuração ao ar livre. Antes de pintar, leia as instruções detalhadas sobre os cuidados e a manutenção:

- Tipo de pintura: As paredes do galpão podem ser pintadas com uma tinta acrílica à base de água para uso exterior. Recomendado: tons claros, sólidos, acabamento de semi-brilho ou cetim. Fale com o seu consultor de cor ou pintor profissional na escolha da pintura.

- Aplicação: Use um rolo para aplicar a tinta sobre a superfície seca da parede. Não pinte os cérvices como feixe nas paredes.

- Não pinte janelas, portas ou feixe de porta, telhado, piso, ou qualquer outra parte do galpão.

Lembre-se: Pintura requer manutenção. Depois de algum tempo, pode ser necessário pintar novamente.

* Para sua segurança - certifique-se de seguir o guia de cuidados e segurança da tinta antes da aplicação.