

FILTRO PERCOLATORE ANAEROBICO CORPO LISCIO DA 400 A 2000 LITRI E DA 3 A 15 A.E.

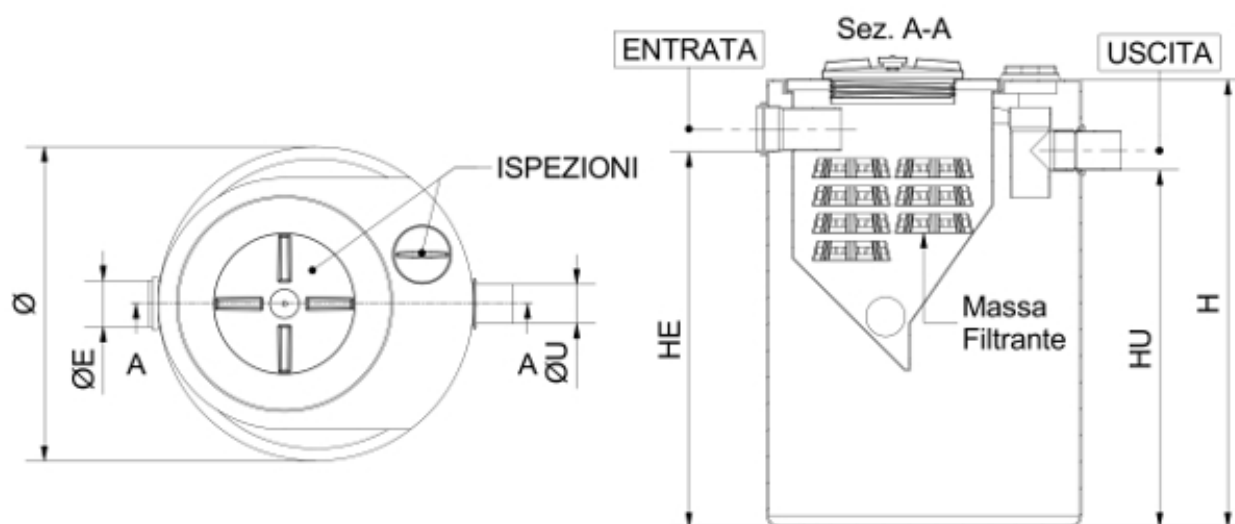

CODICE	CAPACITÀ (lt)	A.E.	Volume utile (mc)	ØxH (mm)	Ø E/U (mm)	HE (mm)	HU (mm)	Ø CHIUSINI (mm)	Peso (kg)
SEPIG01	400	3	0,30	800x800	110/100	635	585	125/300	21
SEPIG02	800	5	0,50	800x1200	110/100	960	910	125/300	27
SEPIG03	1000	6	0,80	1100x1220	110/100	900	850	200/300	37
SEPIG04	1500	10	1,00	1200x1200	125/125	950	900	200/300	47
SEPIG05	2000	15	1,70	1200x1800	125/125	1550	1500	200/300	65